

IMD 135, 170, 210

Ducted Fan Coil Units

Installation & Maintenance

Dimensions (mm)

Not to Scale

Fig. 1

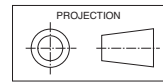

IMD 135, 170

MODEL	A	B	C	D	E
IMD 135	765	265	865	825	945
IMD 170	910	340	1015	975	1095

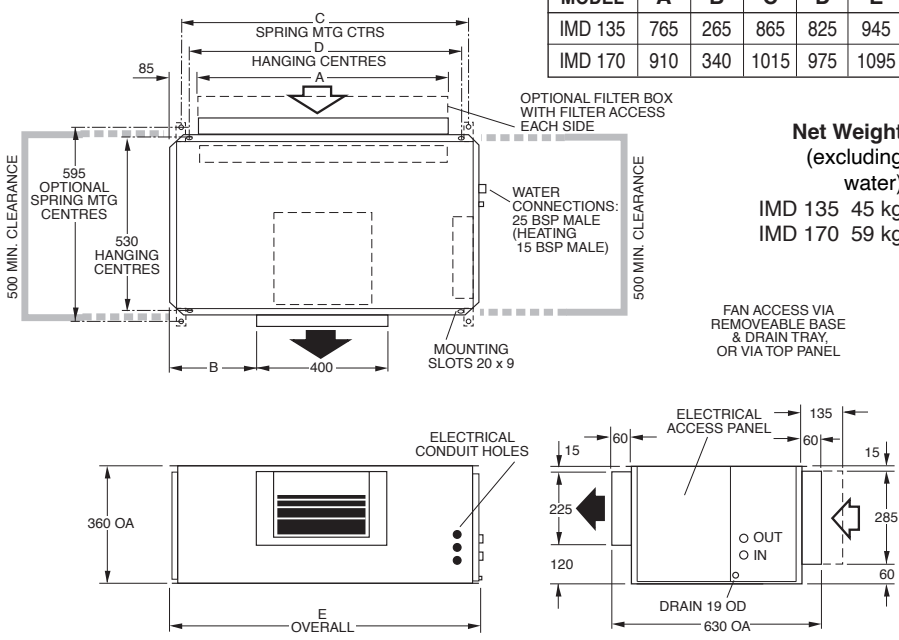

Net Weight
(excluding water)

IMD 135 45 kg
IMD 170 59 kg

GENERAL

The IMD ducted fan coil units must be installed in accordance with all national and local safety codes.

Options

1. Filter Box
2. Spring Mounting Kit
3. Electric Elements c/w fan run-on timer
4. Flexible water hoses

FILTER BOX (Option)

The Filter Box is installed by unscrewing the return air spigot and replacing it with the Filter Box's filter-integrated spigot. The filter may be accessed from either side of this spigot. This new spigot has a depth of 135 mm, instead of 60 mm.

ELECTRIC HEAT (Factory Fitted Option)

Refer to wiring diagram for size of elements supplied. A fan run-on timer for rapid heat dissipation is included with this option. A 24 hour power supply is essential for this timer to function correctly.

INSTALLATION

Positioning & Mounting

When determining the position of the fan coil unit, allow adequate space around the unit to facilitate water pipe/hose connections, future servicing and maintenance. Ensure there is enough working space in front of the electrical access panel. Allow adequate clearance for the filter to be withdrawn to its full length from either end of the unit. Provision should be made for access to remove the unit from the ceiling if the need arises.

If low noise is a critical factor in the installation, refer to Figure 7 for noise isolation recommendations.

It is recommended that the unit be mounted using the spring mounting system, supplied as an optional extra (Fig.4). This system minimises transfer of vibration into the building structure.

If a more rigid installation can be tolerated, then suspend the unit from four threaded rods (not supplied) and use locknuts (not supplied), as shown in Figure 5.

The unit has a built-in sloping drain tray, therefore mount it level.

When finally positioned, tighten the lock nuts on the mounting rods from above and below the mounting flange to give a firm installation (see Fig. 5).

Fig. 2 IMD 210

Net Weight 59 kg
(excluding water)

Not to Scale

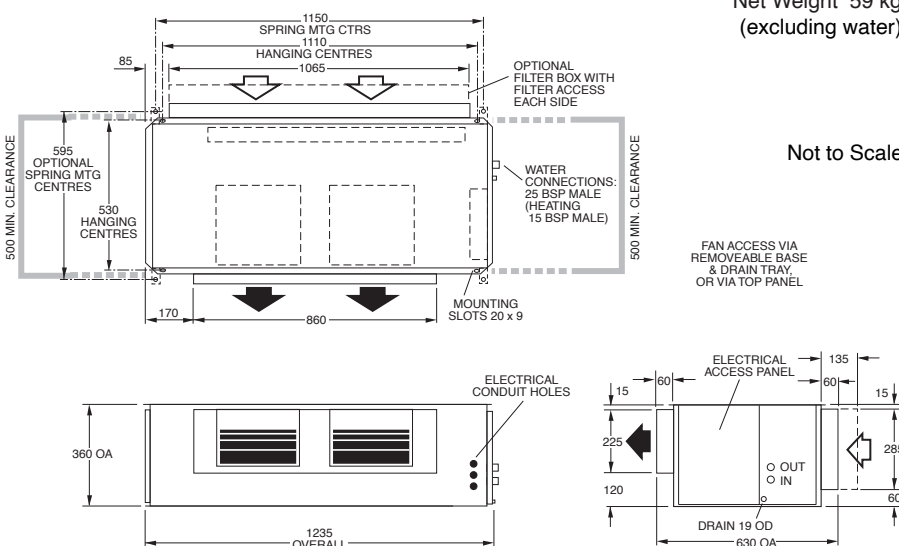

Condensate Drain

The condensate drain should be trapped outside the unit cabinet. The trap should have a vertical height of at least 50 mm. The drain should have a slope of at least 1 in 50 and must not be piped to a level above the unit drain tray. (Refer Fig.6). Use flexible tube to connect the unit's drain stub to the external drain pipe.

For long condensate pipe runs, fit a vent pipe near the drain trap. The top of the vent pipe must be at least 100 mm above the the IMD unit's drain tray.

It is essential that the drainage system is checked by pouring water in the drain tray and seeing that it discharges at the end of the drain and does not overflow the drain tray.

Note: The built-in drain tray can be removed for cleaning (or fan access) by first removing the unit's base.

ELECTRICAL WIRING

The electrical supply required is: 1 phase 220–240 V a.c. 50 Hz with neutral and earth. The supply to have an isolation switch adjacent to the unit but not attached to the unit. Recommended external circuit breaker sizes are as follows:

IMD 135	5 amp
IMD 170	10 amp
IMD 210	10 amp

Electrical work must be carried out by a qualified electrician in accordance with local supply authority regulations and the wiring diagram.

UNITS WITH ELECTRIC HEAT

If electric elements have been included (factory fitted), the electrical supply required is: 3 phase 380–440 V a.c. 50 Hz with neutral and earth. A 24 hour power supply is required to power the fan run-on timer. Recommended external circuit breaker size for a unit factory fitted with electric elements is as follows:

IMD 135	25 A/ph.
IMD 170	25 A/ph.
IMD 210	32 A/ph.

This electric heat kit includes both auto (90°C) and manual (120°C) high temp. safety thermostats. If the manual high temp. safety t/stat requires resetting and the auto high temp. safety t/stat does not reset, then the latter needs to be replaced.

FAN SPEED

The fan speed can be set to LOW, MED, or HIGH - whichever best suits the application.

COMMISSIONING

1. Check that the thermostat is correctly wired and set at the desired temperature.
2. Check that the air filter (if fitted) is clean.
3. Check that the fan runs freely without vibration.
4. Check condensate drain for free drainage.

MAINTENANCE

Weekly For First Four Weeks

1. Check air filter (if fitted); vacuum clean as necessary.
2. Check condensate drain for free drainage.

Monthly

Check air filter (if fitted); vacuum clean as necessary.

Six Monthly

1. Check condensate drain for free drainage.
2. Check heat exchanger coil; vacuum or brush clean as necessary.
3. Check the tightness of the fan.
4. Check that fan motor is free running.
5. Check tightness of electrical connections.
6. Check air supply at diffuser outlets.

NOTE

The manufacturer reserves the right to change specifications at any time without notice or obligation. Certified dimensions available on request.

This pamphlet replaces the previous issue no. 2220 dated 10/22.
Wiring rev. D, Fig.6

Fig. 4 Spring Mounting

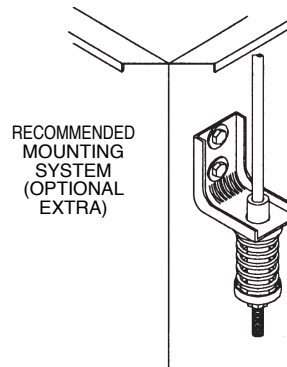

Fig. 5 Solid Mounting

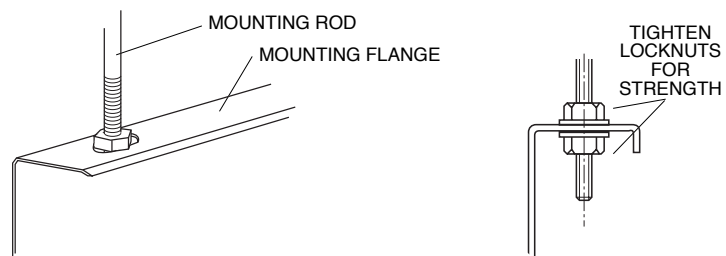

Fig. 6

Condensate Drain

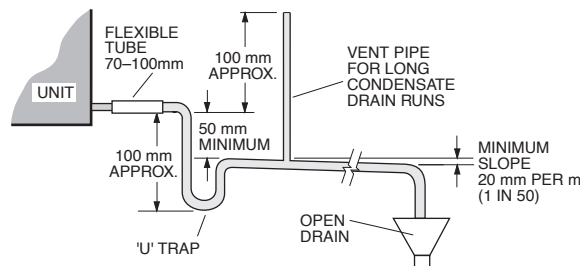
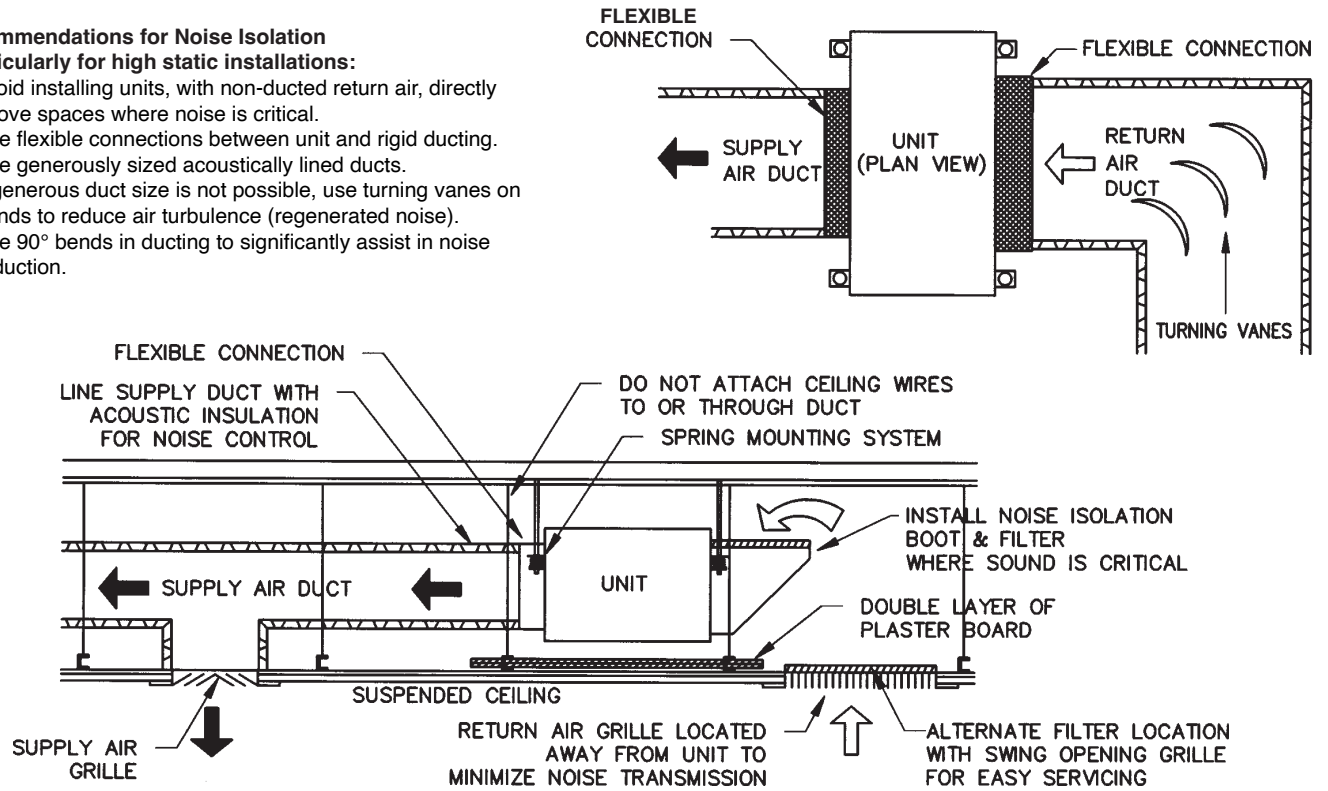

Fig. 7 Application Considerations

Recommendations for Noise Isolation - particularly for high static installations:

1. Avoid installing units, with non-ducted return air, directly above spaces where noise is critical.
2. Use flexible connections between unit and rigid ducting.
3. Use generously sized acoustically lined ducts.
4. If generous duct size is not possible, use turning vanes on bends to reduce air turbulence (regenerated noise).
5. Use 90° bends in ducting to significantly assist in noise reduction.



STANDARD

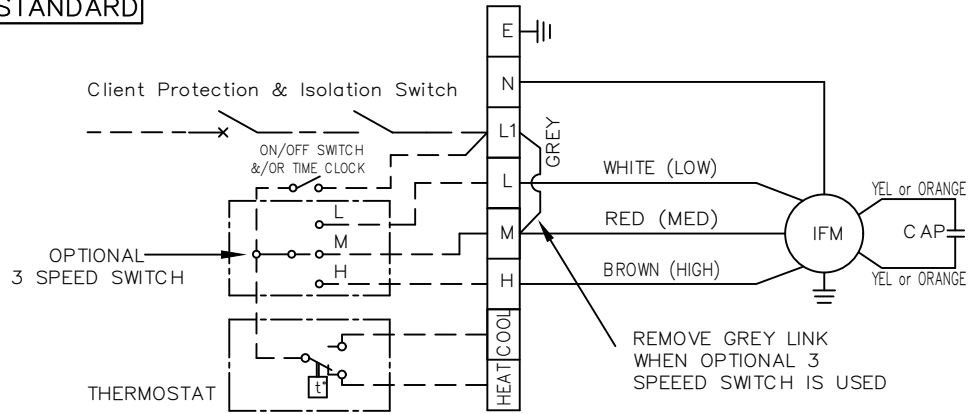

WITH ELECTRIC HEAT

IMPORTANT: 24 HOUR POWER SUPPLY IS ESSENTIAL FOR FAN RUN ON TIMER TO WORK

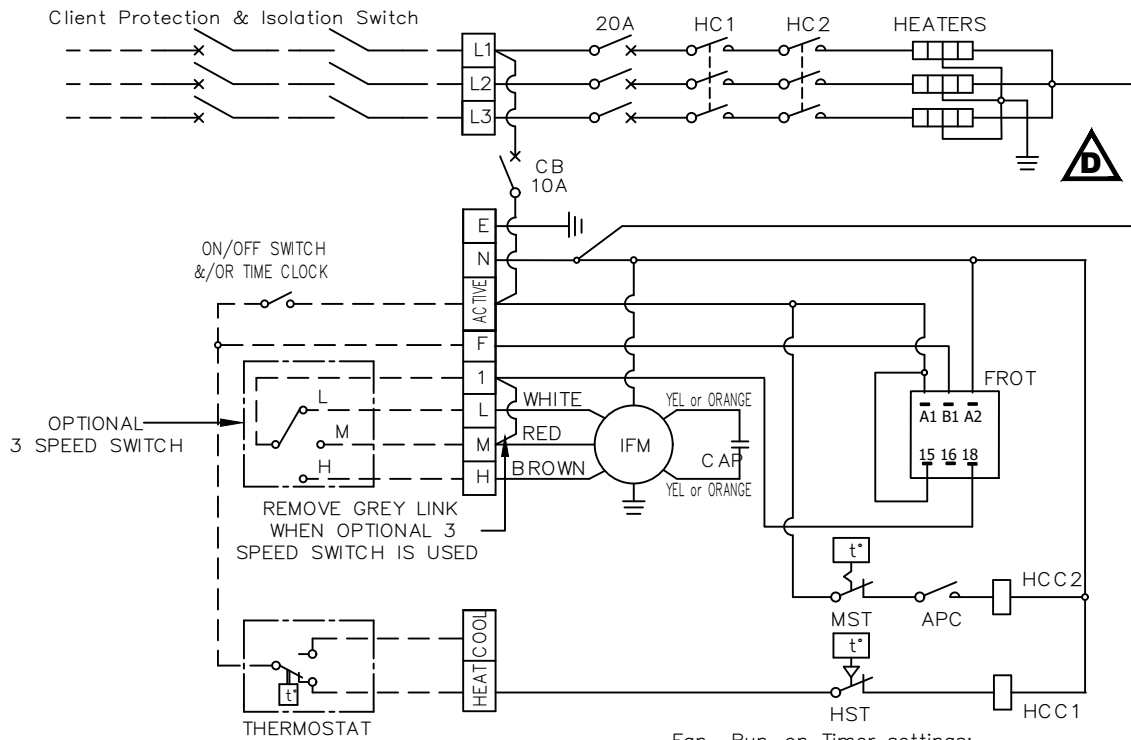

	FAN MOTOR RUNNING AMPS			ELEMENT SIZE
	LOW	MED	HIGH	
IMD135	1.50	2.00	2.60	3 X 2kW
IMD170	2.40	3.00	3.85	3 X 2kW
IMD210	2.30	3.60	5.00	3 X 3kW

Fan Run-on Timer settings:
 Set top 'Mode' selector switch to "sf"
 Set middle "T" to "10m"
 Set bottom "t" selector to ".3"
 CLIENT WIRING -----

Double insulated multi-core cable.
NOTE: CHECK WIRING BEFORE SWITCHING ON. INCORRECT CONNECTION WILL DAMAGE MOTOR.

APC	AIR PRESSURE CONTROL
CAP	CAPACITOR
CB	CIRCUIT BREAKER
FROT	FAN RUN ON TIMER SET TO 3 mins.
HC	HEATING CONTACTOR
HCC	HEATING CONTACTOR COIL
HST	AUTO HIGH TEMP. T/STAT
IFM	INDOOR FAN MOTOR
MST	MANUAL HIGH TEMP. T/STAT

Title **IMD 135/170/210 WIRING SCHEMATIC**



Drawn D.A.B	Date 14-10-99	Drawing No. 400-000-014	Revision D
-------------	---------------	-------------------------	------------