

HITACHI

# Ducted Zone Controlling System

Premium Zoning Solution  
For **airCore700**



WARRANTY

Cooling & Heating



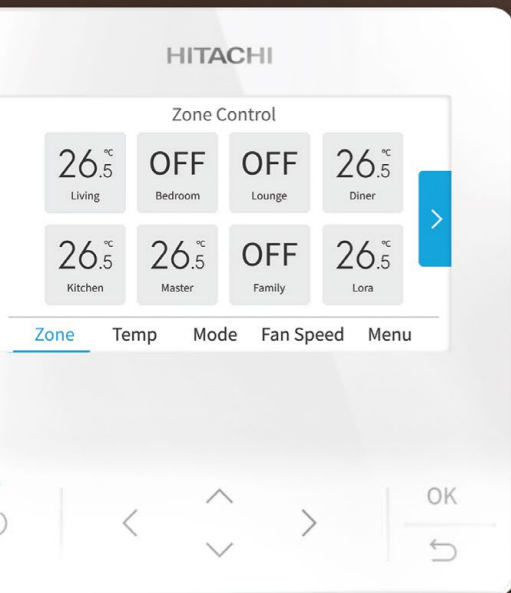

## Contents

- 03 airCore700 Ducted System
- 05 Ducted Systems With Premium Zoning Solution
  - 05 What does the system consist of?
  - 07 Seamless Smart Control, Anywhere, Anytime
  - 09 Compatible with Indoor Units and Outdoor Units
  - 10 System Configuration
  - 12 Apps Control | airCloud Go

# airCore 700 Ducted Systems

















The airCore700 stands as Hitachi's flagship residential ducted split system range. It delivers outstanding cooling and heating performance, showcasing a wide capacity range and efficient operation in diverse ambient temperatures, while guaranteeing uncompromised comfort.

Equipped with low global warming potential R32 refrigerant and remarkable energy efficient, the AC unit not only has a reduced environmental impact but also significantly reduces your electricity bill.

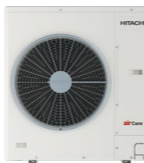
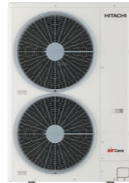

HITACHI DUCTED SYSTEMS PREMIUM ZONING SOLUTIONS

## Product Lineup

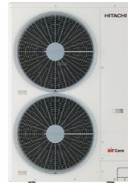
		5.0/6.0kW			6.0/7.5kW			7.2/8.6kW			10.0/11.5kW		12.5/14.0kW		14.0/16.0kW		16.0/18.0kW	
Indoor Unit	Ducted	Mid-Static		 PPIIM-2.0UFA1NQ	 PPIIM-2.5UFA1NQ	 PPIIM-3.0UFA1NQ	 PPIIM-4.0UFA1NQ	 PPIIM-5.0UFA1NQ	 PPIIM-6.0UFA1NQ									
	Ducted	High-Static		 PPIH-3.0UFA1NQ	 PPIH-4.0UFA1NQ	 PPIH-5.0UFA1NQ	 PPIH-6.0UFA1NQ	 PPIH-6.5UFA1NQ										
Outdoor Unit	PAS-*UFASNQ1 (single phase) PAS-*UFASMQ1 (three phase)	 PAS-2.0UFASNQ1	 PAS-2.5UFASNQ1	 PAS-3.0UFASNQ1	 PAS-4.0UFASNQ1 PAS-4.0UFASMQ1	 PAS-5.0UFASNQ1 PAS-5.0UFASMQ1	 PAS-6.0UFASNQ1 PAS-6.0UFASMQ1	 PAS-6.5UFASNQ1 PAS-6.5UFASMQ1										

# Ducted System With Premium Zoning Solution

For homes with existing ductwork or those seeking to install a new multi-zone system on a budget, Hitachi airCore700 ducted zoning system could be the perfect choice.

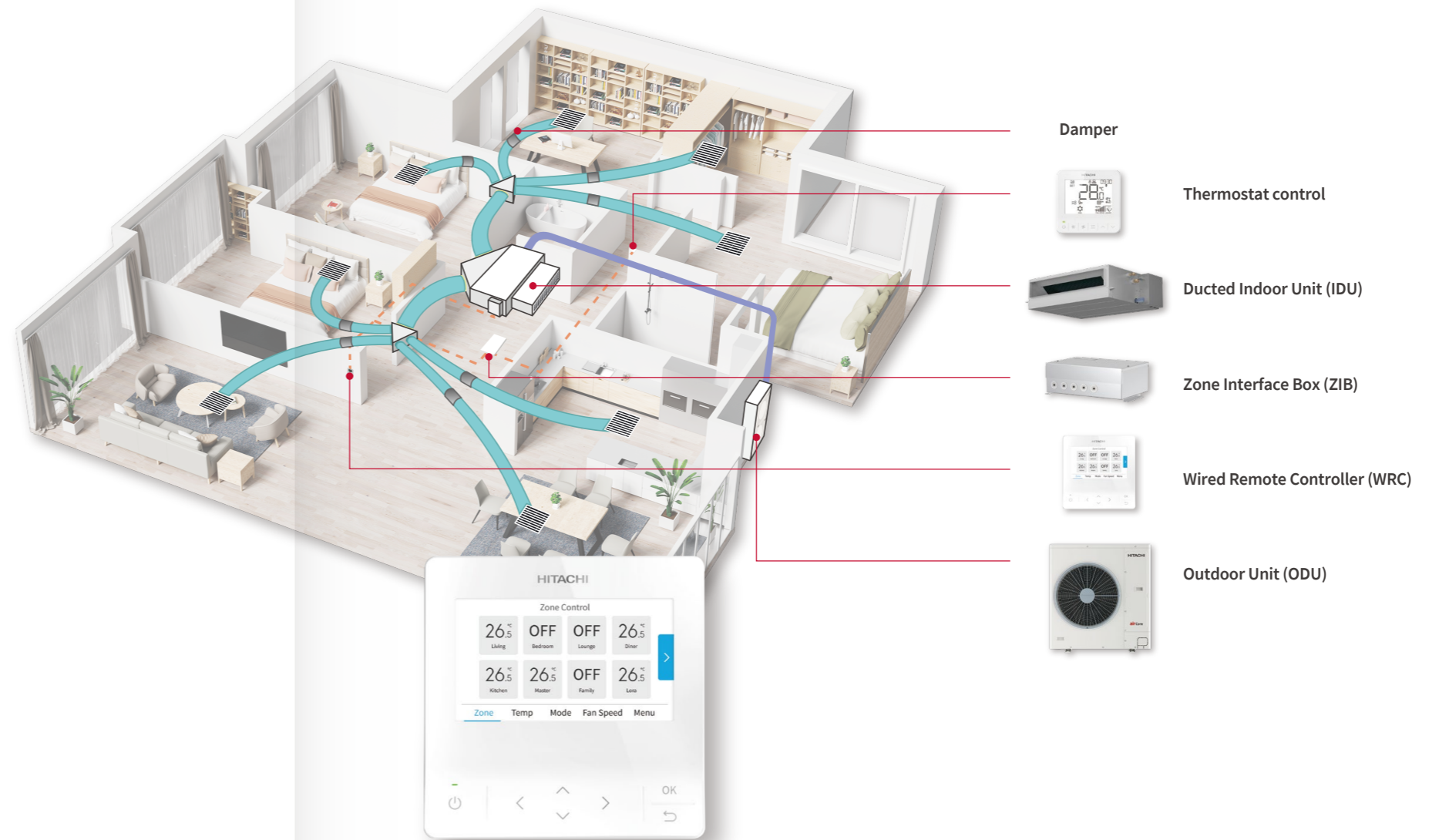

## What does the system consist of?



### Ducted Indoor Unit (IDU)

The Premium Zoning Kit is compatible with airCore700 MESP or HESP ducted-type indoor units, providing for a wide range of ducted layouts and applications. The mid-ESP variant is designed to handle an ESP range of 35~215Pa, while the high-ESP models can achieve high ESP levels up to 35~310Pa.

### Outdoor Unit (ODU)

airCore700 features a new R32 DC inverter compressor, integrating Hitachi's exclusive Compressor Control Technology for enhanced energy efficiency. The unit has transitioned refrigerant to R32, a low GWP refrigerant. R32 not only improves energy efficiency but also reduces emissions, enabling the development of smaller, more compact air conditioning systems with a reduced overall refrigerant requirement. With a GWP of 675, R32 significantly outperforms R410a in terms of environmental impact.

### Damper

The premium zoning ducted system regulates dampers in each duct connected to the air outlet of the indoor unit. These dampers can be activated when there is a demand for air conditioning and deactivated when there is no such demand. By adjusting the damper angle, the airflow rate for each zone can be selected from three settings (High/Med/Low).

### Zone interface box (ZIB)

ZIB with WRC and thermostat are applied for monitoring and controlling of ducted units and dampers. Zone interface box (ZIB) comes with a built-in transformer, providing convenient installation. This integrated 32VA transformer supplies AC 24V power to operate up to eight ON/OFF type damper motors simultaneously.

### Wired Remote Controller (WRC)

Zone control through WRC (Wireless Remote Controller) allows users to set the zone's base temperature on the main screen and individually adjust each zone's status.

### Thermostat

The premium zoning kit supports up to eight thermostats(optional), allowing users to easily configure settings for each zone. The optional remote sensor (THM-R2A) can detect the actual room temperature with or without a thermostat. Users can set a target temperature, and the zoning kit will automatically determine the appropriate damper angle or turn off the zone damper.

# Seamless Smart Control, Anywhere, Anytime

## Component Parts



Zone Interface Box

Model GC-AZKP

Dimension (Width × Height × Depth) 324mm × 226mm × 110mm



Wired Remote Controller

PC-ARFG2-Z

120mm × 120mm × 16.5mm (thinnest part)

120mm × 120mm × 21.5mm (thickest part)



Thermostat (optional)

GC-ZKT

90mm × 90mm × 15.5mm (thinnest part)

90mm × 90mm × 18.5mm (thickest part)



Remote Sensor (optional)

THM-R2A

50mm × 50mm × 15mm (wire: 8m)

Once your ducted AC is connected to a premium zoning system, the Zone Interface Box (ZIB) will prompt the wired remote controller (WRC) to automatically display the options for zone control functions.

## Zone Type Identification

- Common zone: zone without damper (this zone will not be able to be controlled)
- Enabled zone: zone with damper.
- Spill zone: special enabled zone, damper might be automatically opened to ensure IDU's minimum airflow rate.

## Built-in Transformer

For ease of installation, the ZIB features a built-in 32VA transformer capable of supplying AC 24V power to up to eight ON/OFF-type damper motors simultaneously.

## Temperature Control

Premium zoning kit can detect each zone's actual room temperature, and control damper to achieve user setting temperature which can be set through WRC or thermostat. The temperature settings for each zone will be confined to the range determined by the base zone temperature, indicating that the temperature control for each zone is closely linked to the IDU temperature settings.

## Damper Angle Control

Damper motor operating time input, achieving damper angle control, to offer user to control airflow rate of each enabled zone.

## Damper Angle Auto Linkage with IDU ESP

When the IDU operates in auto ESP mode, the zoning kit will adjust the damper's angle for the Low/Medium/High taps to achieve precise control based on the IDU ESP value.

## Zone Auto Fan

Users can set the zone airflow rate control mode to "Auto," allowing the zoning kit to automatically regulate damper angles based on the difference between the actual room temperature and the set value. The IDU fan tap will also be automatically managed by the premium zoning kit; manual user settings are not required.

## Zone Labeling

The names of all zones and remote sensors can be freely modified according to the specific zone application. This convenience enables users to easily identify the zone they are operating on, with names allowing for up to 12 characters.

## Zone Status Set and Display

The Wired Remote Controller (WRC) can both set and display the status of all zones. The thermostat can similarly set and display the status of its specific zone.

## Simple Timer and Operation Schedule

The Simple Timer program allows you to schedule your zoning system to run or stop after a pre-set number of hours. The Operation Schedule program simplifies the process of programming the system's run/stop status, setting temperature, and zone ON/OFF according to a specified date and time, allowing for up to 5 cycles from Monday to Sunday in a single day. This function enhances user comfort and convenience by aligning with their daily living habits.

## One Button To Open All Zones

The service function can open all zone dampers with a single button through the Wired Remote Controller (WRC).

# Compatible with Indoor Units and Outdoor Units

The Premium Zoning Kit is developed for airCore 700 MESP and HESP ducted type indoor units.

Capacity	airCore 700 Indoor Unit	
	MESP Ducted	HESP Ducted
2.0 HP 5.0 kW	PPIM-2.0UFA1NQ	/
2.5 HP 6.0 kW	PPIM-2.5UFA1NQ	/
3.0 HP 7.2 kW	PPIM-3.0UFA1NQ	PPIH-3.0UFA1NQ
4.0 HP 10.0 kW	PPIM-4.0UFA1NQ	PPIH-4.0UFA1NQ
5.0 HP 12.5 kW	PPIM-5.0UFA1NQ	PPIH-5.0UFA1NQ
6.0 HP 14.0 kW	PPIM-6.0UFA1NQ	PPIH-6.0UFA1NQ
6.5 HP 16.0 kW	/	PPIH-6.5UFA1NQ

The combination method between the premium zoning kit and indoor unit should involve only one premium zoning kit corresponding to one set of IDU+ODU (as shown below). Any other combination connection methods should not be used.

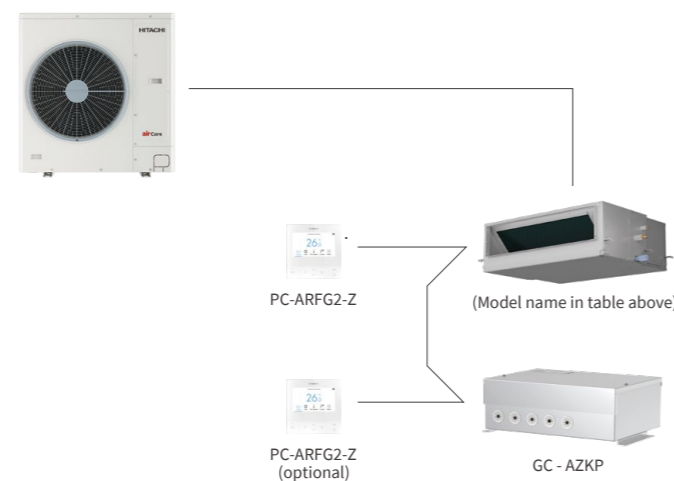

# System Configuration

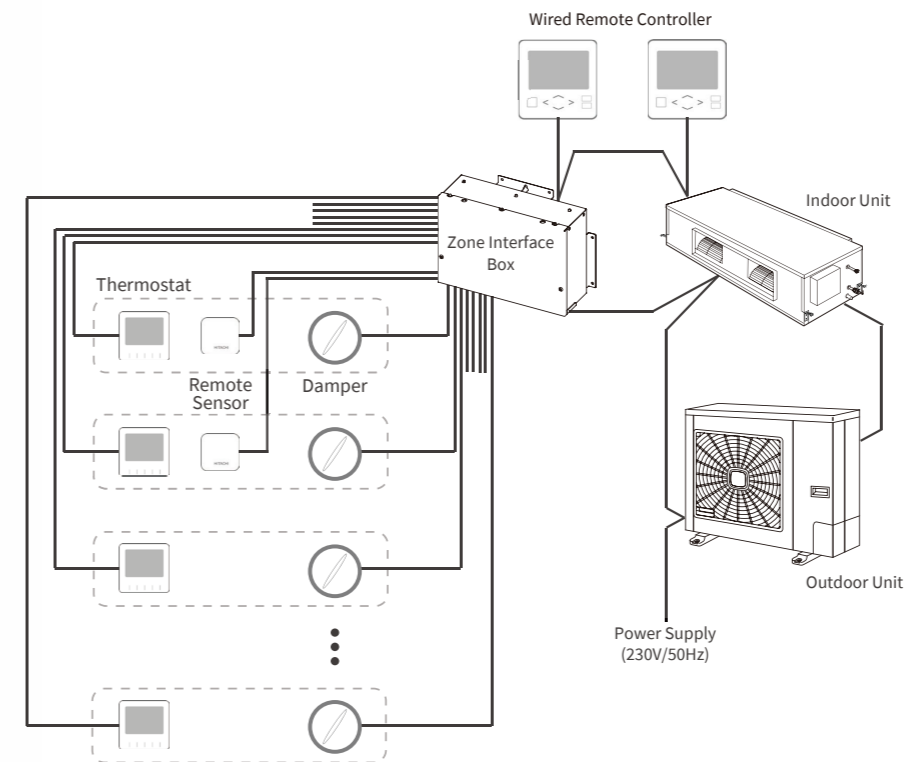

- NOTE:**
- Control functions are available with at least one WRC (PC-ARFG2-Z) being connected. Zone control functions are not available with other types of WRCs.
  - Any types of central controller cannot be connected.
  - Only one ZIB can be connected in one zoning system.
  - One ZIB can only support one indoor unit.
  - One ZIB can control up to eight zone damper motors.
  - Up to two WRCs(PC-ARFG2-Z) can be connected in one system.
  - Up to two remote sensors can be connected in one system.
  - Up to eight thermostats can be connected in one system.
  - Careful attention must be given to assure that the airflow rate through the indoor fan coil unit is within the allowable range as specified in the technical catalogue of indoor unit.

# Standard Specification

## Zone Interface Box Hardware Specification

Item	Specification
Dimensions (W×H×D)	324mm × 226mm × 110mm
Net Weight	3.95Kg
Installation Condition	Wall mount or mounting on surface
Ambient Temperature	-20°C~60°C
Ambient Humidity	10%~95%(should not cause dew)
Power Supply	AC 230V/50Hz
Power Consumption	Standard Input 10W
Dampers Control	Up to 8
Power Supply for Damper	AC 24V 32VA (per dampers≤4 VA)
Thermostat Connection	Up to 8 thermostats, the max wire length of each thermostat is 50m.

## Damper Hardware Specification (Field-supplied)

Item	Specification
Voltage	AC 24V
Frequency	50Hz
Maximum operating current (per damper)	167mA or less
Maximum electric power (per damper)	4VA or less
Cable Type	RJ12 or 3 wires

- NOTE:**
- The ZIB is designed to operate with drive open and drive close type zone control motors only. Spring return motors cannot be used. Damper for each zone should share one damper timing.

Communication cables among the Wired Remote Controller (WRC), indoor unit, and Zone Interface Box (ZIB) are illustrated as below:

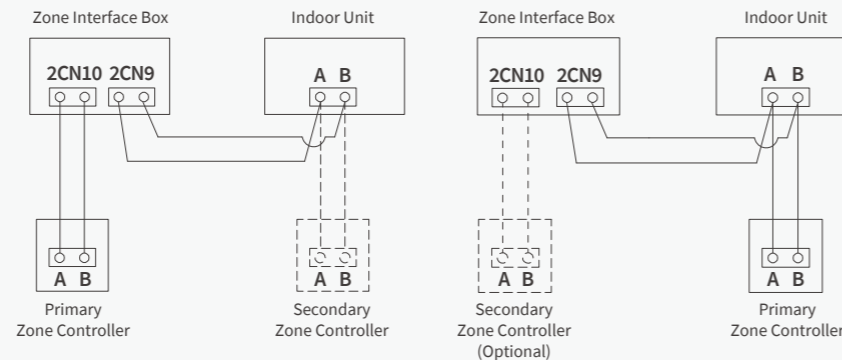

- NOTE:**
- Premium zoning kit can not support the previous zoning kit, whose model name as below:  
Zone interface box: HZBB10NESQ  
Zone controller: PC-ARFZ
  - Communication cable is not needed between ZIB and outdoor unit.



# Apps Control airCloud Go

Remotely control individual indoor units or premium zoning systems.\*

 **airCloud Go**  
Connect your Hitachi air conditioners to airCloud Go via wifi.

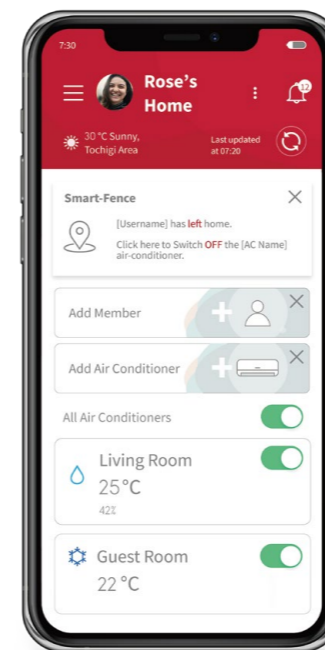
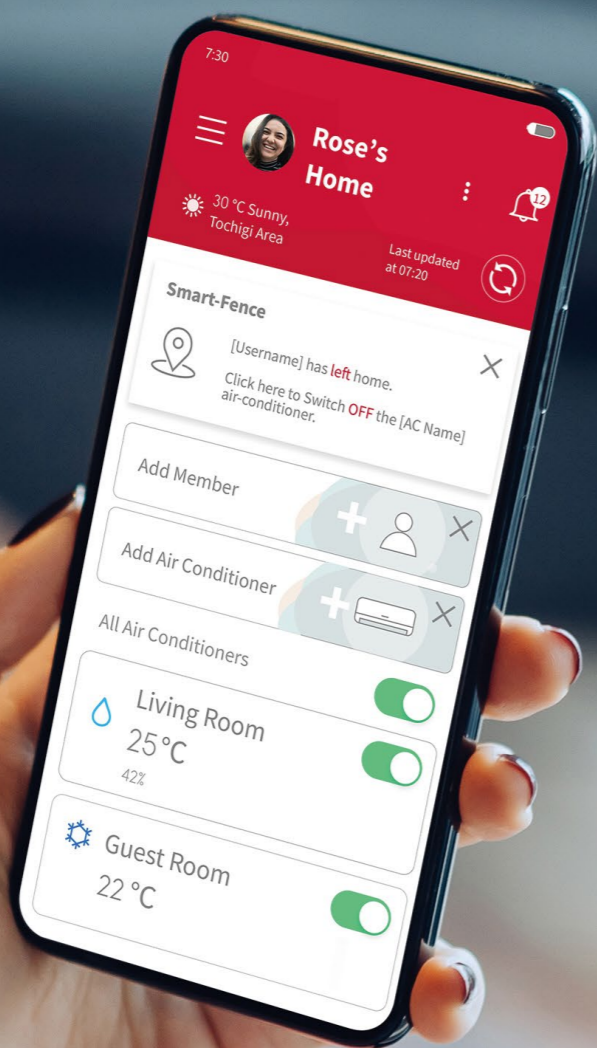

Turn the air conditioner on/off and set the desired temperature, fan speed and airflow direction.

Program your air conditioning operation with the Simple Timer and/or Weekly Timer.

Pair your account with unlimited air conditioners.

Invite up to 20 users to manage each air conditioner.



**Voice control**  
Connect with your smart speaker and set your indoor climate via voice control.



 **App available in 21 languages**

English, French, Italian, Spanish, German, Portuguese (BR & EU), Dutch, Danish, Swedish, Thai, Chinese (Traditional & Simplified), Indonesia, Polish, Hungarian, Czech, Romanian, Greek, Croatian, Slovenian, Vietnamese, Malay

Control your AC from anywhere!

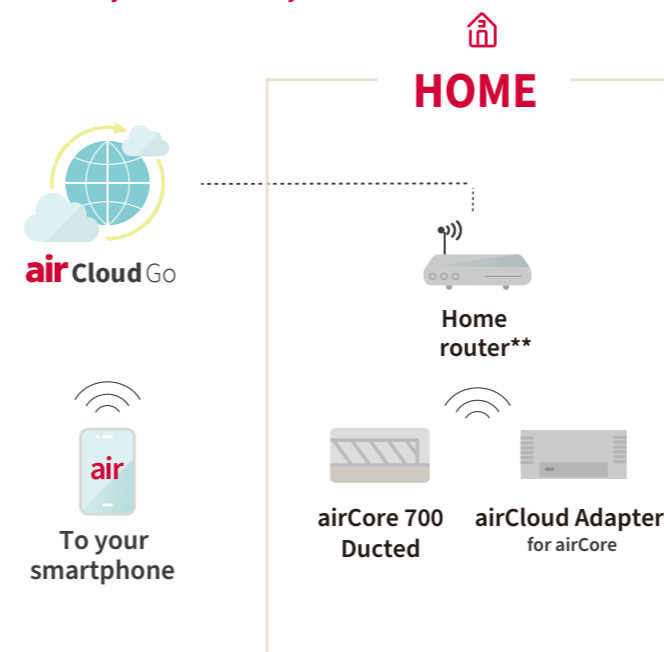

**airCloud Adapter (GA-WFG)**

Introducing the new airCloud Adapter, compatible with the airCloud Go App, enabling remote control of airCore 700 Ducted systems.

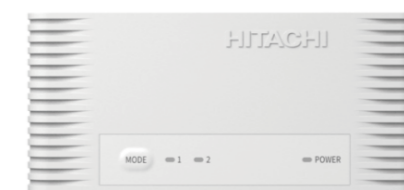

**Quick set up**

QR code recognition enables you to pair your app to your air conditioner in an instant.

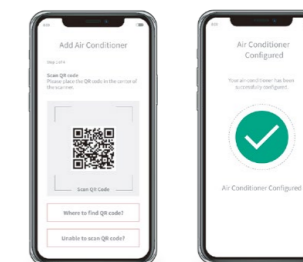

\*airCloud Go SmartFence & energy monitoring not available with airCore 700



## Temperzone Ltd

### ENQUIRIES

ausales@temperzone.com  
nzsales@temperzone.com

### AUSTRALIA

Sydney: (02) 8822 5700  
Melbourne: (03) 8769 7600  
Brisbane: (07) 3308 8333  
Adelaide: (08) 8115 2111

### DISTRIBUTORS

Newcastle: (02) 4962 1155  
Perth: (08) 6399 5900  
Launceston: (03) 6331 4209

### NEW ZEALAND

Auckland: (09) 279 5250  
Wellington: (04) 569 3262  
Christchurch: (03) 379 3216

## Hitachi Cooling & Heating Official Distributor



WARRANTY

[hitachiaircon.com.au](http://hitachiaircon.com.au)  
[hitachiaircon.co.nz](http://hitachiaircon.co.nz)



The specifications of this catalogue may change without prior notice to allow Hitachi Cooling & Heating to incorporate the latest innovations for its customers. The information contained in this catalogue is merely informative. Hitachi Cooling & Heating declines any responsibility in the broadest sense, for damage, direct or indirect, arising from the use and / or interpretation of the recommendations in this catalogue.