



# Water Cooled Unit

## Technical Data

---

CWP 90 Eco Ultra R32



**Cooling Capacity**  
4.1kW – 10kW

**Heating Capacity**  
3.7kW – 8.9kW

# Water Cooled air conditioner

## Contents



<b>CWP 90RELSFY Eco Ultra</b>		<b>TZT-100 CONTROLLER (Optional)</b>	
Introduction	4	Features Summary	9
Features	5	<b>PERFORMANCE DATA</b>	
Refrigerant R32	5	Cooling Capacity (kW)	10
Efficient	5	Reverse Cycle Systems / Heating Capacity (kW)	10
ThermoShell® Technology	5	Air Handling	11
Performance	5	Water Flow vs Water Pressure	11
Durable	5	Sound Levels	13
Quiet	5	Supply Air Outlet	13
Safety	5	Supply Air Outlet + Insulated Duct	13
Insulation	5	Case Breakout + Return Air	13
Control Options	5	Sound Pressure Levels (SPL) Within A Room	14
Self Diagnostics	6	<b>DIMENSIONS (mm)</b>	
Peace of Mind	6	CWP 90RELSFY	14
Electric Heating	6	<b>SPECIFICATIONS</b>	
Accessories	6		15
Optional Equipment	6		
Installation	6		
Water Connection	7		
Safety Features	7		
Electrical	7		
Nomenclature	8		

# Water Cooled air conditioner

CWP 90RELSFY Eco Ultra



This Eco Ultra Packaged Closet unit provides the ultimate flexibility and performance demanded in residential environments. Key benefits are energy efficiency and the reliability and durability inherent in a factory assembled packaged system.



# Water Cooled air conditioner

## CWP 90RELSFY Eco Ultra



### Applications

The CWP units are ideal for multi-unit installations such as high-rise office, apartments or hotel buildings, where the flexibility of individual zone control is required.

## INTRODUCTION

The temperzone CWP-RELSFY Eco Ultra Series represents a range of ducted, water sourced, packaged air conditioners designed to provide year round comfort to room occupiers.

Compact and reliable, these units are designed to be installed in a cupboard or in other concealed spaces and providing conditioned air direct to necessary locations.

CWP Series units are designed to be used with simple duct layouts. To take maximum advantage of this feature, units should be located as close to the space to be air conditioned as acoustic criteria allows. Multiple small units, utilizing minimal duct lengths, prove more economical than a single large central ducted unit.

The standard unit is reverse cycle, providing both cooling or heating, plus electric heat back-up.

In office buildings, an CWP unit system can provide the ideal off-peak system for occupied areas when the main system is not running, e.g. night time, weekends, holidays.

CWP unit systems can be applied to provide owner occupiers with individual control and billing, thus avoiding large central plant room areas, e.g. in apartment buildings.

Installing multiple reverse cycle versions enables simultaneous heating and cooling in different parts of a building.

Multiple CWP units are typically part of an overall hydronic system that incorporates some form of heat rejection equipment – usually a cooling tower or dry air cooler (radiator).

CWP units are an ideal replacement for older R22 models (CC 150/225, 2/150, 2/225) as they have a similar footprint.

# Water Cooled air conditioner

## CWP 90RELSFY Eco Ultra



### FEATURES

#### Refrigerant R32

Each unit is factory charged with refrigerant R32, which has a very low GWP. This gas is mildly flammable (Class AL2) and therefore the unit must be stored and installed in a ventilated space, away from continuously operated sources known to cause ignition of R32.

#### Efficient

These air conditioners provide one of the most efficient forms of cooling and/or heating you can invest in, as evidenced by their high EER figures. Each unit include a high efficiency electronically commutated (EC) fan motor. Part load operation at low loads (75% airflow equates to 55% power use) using temperzone algorithms. Each unit incorporates a high efficiency inverter compressor that provides variable capacity (40-120%) performance and close temperature control. It is very efficient at part load. Extra boost capacity is available for fast response when well away from set point at start-up. Heat exchange air coils use inner grooved (rifled) tube for better heat transfer. Integrated heat recovery ensures highest efficiency heating by extraction of the maximum energy from the water loop.

CWP 90RELSFY may be suitable for applications using full or high proportions of fresh air (nb pre-heating on heating cycle may be required); also for VAV, close control and supply air temperature control. Refer to temperzone Engineering.

#### Thermoshell® Technology

The unit includes a compact long life highly efficient water heat exchanger design with non-fouling properties.

#### Performance

A dynamically balanced forward curved fan with a variable speed EC motor enables fine tuning of the indoor unit to match the supply air requirements. These EC motor fans have a fully integrated speed control that enables soft starting. Fan speed can be stepped to your own requirements or continuously variable using a 0-10V DC control signal. Electronic expansion valves (EEV) in the refrigeration system enable optimum cooling performance.

#### Durable

Temperzone units have a tough galvanised steel construction - polyester powder coated (grey). The air coil is die formed plate type epoxy coated aluminium fins mechanically bonded to high efficiency inner grooved copper tubes. Each CWP unit alone

(excluding hoses) will withstand a maximum water pressure of 3200 kPa (464 psi). Condensate drain trays are insulated and powder coated for complete moisture protection.

#### Quiet

CWP units have bonded polyester lined compressor and fan compartments to minimise noise.

#### Safety

Units are fitted with a high pressure lockout that protects the unit in the event of water flow failure in cooling mode. Sensors protect against low air coil temperature and loss of refrigerant. Units include an anti-rapid cycle timer for compressor on/off protection.

CWP reverse cycle units also have a low refrigerant pressure sensor to protect against icing-up of the water within the unit's ThermoShell® condenser on heating mode and a water pump flow verification input to protect individual units from a loss of water flow.

Convenient lockout contactor resetting is simply achieved by turning the power to the unit off and then on again, avoiding the need to gain access to each unit if the cause is failure of central water supply.

Each compressor has internal overload protection.

The CWP reverse cycle version has a low refrigerant pressure limit and a reverse cycle change-over valve.

#### Insulation

Closed cell foam insulation has been used to inhibit mould growth in places where moisture could be present. Bonded polyester insulation ensures no particles are introduced into the air stream. Insulation is foil faced and meets fire test standards AS 1530.3 (1999) and BS 476 parts 6 & 7.

#### Control Options

The unit's UC8 Controller can be connected to Temperzone's TZT-100, Touch Mini or other compatible room temperature controllers supplied by others. It is BMS compatible via Modbus/RS485 port with multi-unit control possible - either via digital and analogue signals or via Modbus. The UC8 can activate the water circulating pump (only when required) and/or a local water on/off valve, thus saving pump running costs.

Commissioning is made easier when the EC fan motor to be controlled variably (within a restricted range) by a 0-10 volt DC signal that can be supplied either by a BMS system, a sophisticated controller or temperzone's optional TZT-100 Controller.

# Water Cooled air conditioner

## CWP 90RELSFY Eco Ultra



### Self Diagnostics

Any faults detected are displayed on the UC8 and optional TZT-100 Wall plaque. General fault and run status output signals are available for remote fault indication to building management systems.

### Versatile & Convenient

Water connections to the unit can be made via the top or the front of the unit – can be chosen on site. All electrical service connections are via the front panel. Filters are easily accessible. The unit has a similar footprint to the earlier CC300 model, which makes replacement easier.

### Peace of Mind

Temperzone operates a quality management system that conforms to AS/NZS ISO 9001:2015. The company's products have been selected, against worldwide competition, for use in some of the most exclusive projects – chosen because of their proven efficiency, durability, performance, reliability and value.

### Electric Heating

On heating, the UC8 looks at the entering water temperature and if this is below 10°C it will activate the electric standby elements to warm the air stream and achieve the room thermostat setpoint. If the water temperature is above 10°C, the CWP will action the reverse cycle heating and compressor. If the evaporating temp. consistently stays below -10°C and/or the entering water temp. drops consistently below 5°C, the UC8 will stop the compressor and revert to standby electric heat.

Electric element/s have spiral wound stainless steel fins to give increased area and low surface temperature. They are totally enclosed within the unit and are supplied with auto (90°C) and manual (120°C) high temp. safety thermostats required to meet AS/NZS 60335.2.40 2015. A fan run-on timer for rapid heat dissipation is incorporated into the UC8 as well as a 70° fast acting temperature sensor to ensure overall safety.

## ACCESSORIES (SUPPLIED)

### Air Filter

Each unit is supplied with a washable synthetic fibre EU2/G2 rated filter that is integrated with the return air spigot. This filter complies with AS/NZS 1324.1:2001.

## OPTIONAL EQUIPMENT

### 1. Flexible Hoses

High pressure hoses are available for water connections. The hoses have female pipe threaded nut fittings at both ends. Maximum water pressure for 600 mm length is 2070 kPa (300 psi).

### 2. TZT-100 or Touch Mini Controller (page 9)

Connection cables supplied separately.

## INSTALLATION

### Ventilation

The system shall be installed, operated and stored in a ventilated space where there is no continuously operating open flames, eg an operating gas appliance, or other R32 ignition source.

### Mounting

It is recommended that CWP units be mounted on vibration isolating pads to minimise any transfer of vibration into the building structure.

### Positioning

When determining the installation location consideration should be given to each unit to facilitate future servicing and maintenance, e.g. room for removal of filter and access to electrics, access times.

### Condensate Drain

The condensate drain should have a slope of at least 1 in 50 and must not be piped to a level above the unit drain tray. If necessary, an external condensate lift pump should be installed. Lift pump activation terminals are provided. The unit includes a built-in U trap.

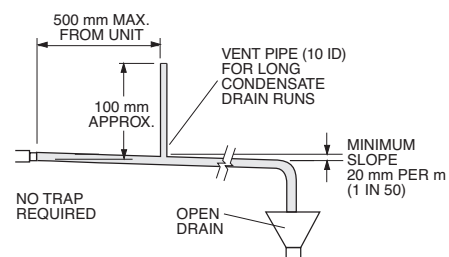

# Water Cooled air conditioner

## CWP 90RELSFY Eco Ultra



### WATER CONNECTION

#### General

Water connection to the unit can be made either via the top or the front of the unit, ie site selectable. The CWP unit's IN and OUT water connections are male pipe threaded. The unit can be piped directly or by using two temperzone flexible high pressure water hoses (optional) which have female pipe threaded connections at each end.

Poor quality water supply must be pre-filtered and it is essential that adequate water treatment is maintained, particularly where open cooling towers are used.

Note: It is recommended that the water supply system be fitted with a water flow switch and water flow verification circuit. These items prevent the CWP units from going into fail safe lockout status due to a loss of water flow. Failure to install the above items could require the resetting of all CWP units in the system – by breaking the power supply to each unit or by Modbus command.

#### Water Control

A Water Shut-Off Valve is supplied built-in and connected to the UC8 controller; refer wiring diagram. The valve is closed when the compressor is off; fully open when the compressor is on.

This valve control system ensures water does not flow through the unit when it is not operational for a long period of time, thereby reducing the overall central pump power usage. The UC8 controller performs a periodic water-flush-cycle to minimize the risk of stagnant water and fouling when the unit is off for long periods.

#### Circuit Balancing Valve

It is recommended that a circuit balancing valve be fitted to maintain water flow at a constant rate. The water flow rates in litres per second (l/s), at nominal water temperature, are stated in the Specifications Table (pages 26,27). The water circuit needs to be balanced to suit the design  $\Delta T$  of the central water system.

The CWP unit controller (UC8) will protect the refrigeration system of the unit under extreme conditions. On heating cycle it protects to ensure the evaporating temperature does not drop below freezing point for an extended period. **It is important that the leaving water temperature does not fall below 4°C.** The entering water temperature will determine how low the water flow can be allowed to go without causing nuisance trips from this protection. Refer page 14 for flow data.

#### Water Circulating Pump & Flow Verification Option

In order to promote efficiency and avoid running the water circulation pump unnecessarily, the unit's UC8 Controller can be used to control the activation of the pump prior to running the compressor. After activation of the circulating pump contactor (not part of the CWP unit), the UC8 waits for the pump flow verification relay contact (PFVR) to close before energising the compressor contactor (CMC) and therefore starting the compressor (refer wiring diagram). The UC8 also de-activates the pump when the compressor stops.

### UNIT PROTECTION FEATURES

1. HP and loss of refrigerant protection.
2. Anti-rapid cycle timer and internal overload for compressor protection.
3. Circuit breaker control circuits.
4. Electronic pressure control prevents icing up of the Thermoshell® heat exchanger during heating cycle.
5. Frost protection on cooling cycle.
6. Sensor fault indication.
7. Compressor minimum run time to ensure oil return.

### ELECTRICAL

The electrical supply required is: 1 phase 230 V a.c. 50 Hz with neutral and earth.

The unit is compliant to the latest MEPS standards.

# Water Cooled air conditioner

## CWP 90RELSFY Eco Ultra



### NOMENCLATURE

Example

Series	Size	Type
<b>C</b> - Closet <b>W</b> - Water Sourced <b>P</b> - Packaged	<b>90</b> Divide by 10 to get approx. nominal Capacity in kilowatts	<b>R</b> - Reverse cycle <b>E</b> - Electric heat (standby) <b>L</b> - Refrigerant R32 <b>S</b> - Single phase power supply <b>T</b> - Three phase power supply <b>F</b> - Inverter compressor <b>Y</b> - EC fan motor

### TECHNICAL SUPPORT

For more information on the manufacturer or product support information, visit the website [www.temperzone.biz](http://www.temperzone.biz)



# Water Cooled air conditioner Controllers (Optional)

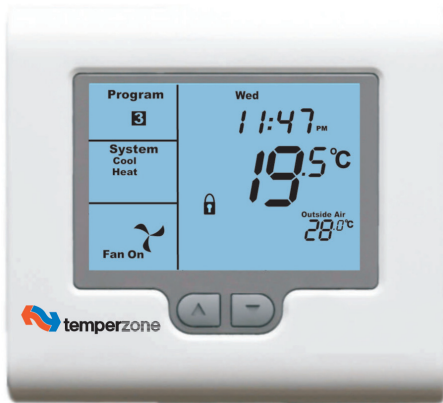

## TZT-100

- Cool / Cool Dry / Heat / Auto Dry / Auto / Fan Only modes.
- Auto / High / Medium / Low fan speed selection. (customisable).
- Temperature setting range from 1°C – 38°C.
- LED to indicate status of the unit [Power On/Off].
- Room & set temperature display.
- Real time clock.
- 12 or 24 hour time display
- °C or °F display
- **7 day timer** – up to two events (four start and/or stops per day)
- On demand countdown run timer, up to 9 hours.
- Auto-Restart or No Restart after power failure
- Continuous or Intermittent selection of fan run-on in dead zone.
- Backlit screen for ease of reading;
- Soft touch tab keys
- PIN protected menus (Installer PIN)
- Keypad and/or temperature lock
- Filter monitor option (by hours)
- Occupancy sensor inputs
- Integrated Modbus option
- Battery backup (Lithium).
- **Sleep function** – improves night time comfort and saves energy.
- Audible beep to acknowledge key entry or wireless remote control.
- 24V control cable.
- Optional remote air temperature sensor

For more information visit  
[www.temperzone.biz](http://www.temperzone.biz); model search 'TZT-100'.



# Water Cooled air conditioner

## Eco Ultra Performance Data



### AIR HANDLING

Airflows are for a dry coil. Reduce airflow by 10% in high moisture removal conditions. In a free blow application, beware of exceeding fan motor's full load amp limit. **Air flows given are for CWP units without filter installed.**

#### CWP 90RELSFY-S2

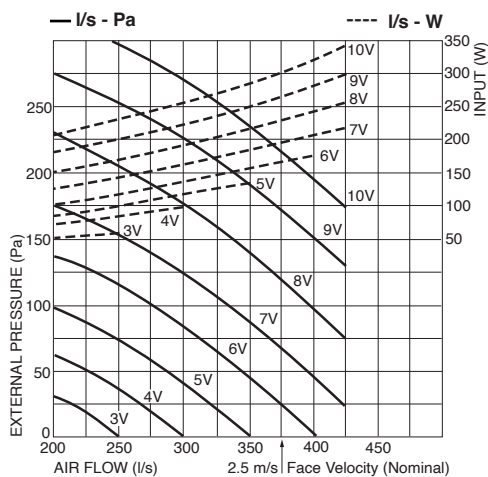

Note

1. In tropical (high humidity) conditions care must be taken to select an air flow which gives a suitable coil face air velocity, to prevent water carry over.
2. Applications using high proportions of fresh air should be referred to Temperzone to establish the correct selection of units.

#### Pressure Drop - EU2/G2 rated filter media (clean):

Coil Face Velocity (m/s)	1.5	2.0	2.5
Pressure Loss (Pa)	15	25	40

### WATER FLOW VS PRESSURE DROP

The chart below shows Water Flows and Pressure Drop at varying water temperature differences.

Nominal water flow is at a Water Temperature difference of 5K. The reduced water flows shown below have minimal effect on performance.

Model:	CWP 90	
THR	12.6	
Water Temp Difference K	Water Flow l/s	Press Drop kPa
5.0	0.60	62.0
5.5	0,55	51.7
6.0	0.50	43.5
6.5	0.46	37.0
7.0	0.43	31.9
7.5	0.40	27.8
Min. water flow	0.17	5.0

THR = Total Heat Rejection (kW)

# Water Cooled air conditioner

## Performance Data



### SOUND LEVELS

Sound Power Levels (SWL)

Test Conditions:

SPL measured to JIS 8616 (1m from source in an anechoic chamber)

### SUPPLY AIR OUTLET

Model	FAN SPEED	SOUND PRESSURE LEVEL SPL dB(A)	SOUND POWER LEVEL SWL dB(A)	OCTAVE BAND FREQUENCY Hz					
				125	250	500	1K	2K	4K
CWP90	9V	75	<b>86</b>	77	74	79	81	81	78
	7V	69	<b>80</b>	70	69	73	76	75	72
	5V	63	<b>74</b>	65	62	67	70	67	64
	3V	53	<b>64</b>	59	52	60	60	57	53

### SUPPLY AIR OUTLET + INSULATED DUCT

Model	FAN SPEED	SOUND PRESSURE LEVEL SPL dB(A)	SOUND POWER LEVEL SWL dB(A)	OCTAVE BAND FREQUENCY Hz					
				125	250	500	1K	2K	4K
CWP90	9V	61	<b>72</b>	63	60	65	67	67	64
	7V	57	<b>68</b>	58	57	61	64	63	60
	5V	53	<b>64</b>	55	52	57	60	57	54
	3V	46	<b>57</b>	52	45	53	53	50	46

### CASE BREAKOUT + RETURN AIR

Model	FAN SPEED	SOUND PRESSURE LEVEL SPL dB(A)	SOUND POWER LEVEL SWL dB(A)	OCTAVE BAND FREQUENCY Hz					
				125	250	500	1K	2K	4K
CWP90	9V	65	<b>76</b>	74	71	71	71	70	65
	7V	60	<b>71</b>	69	67	66	68	64	59
	5V	54	<b>65</b>	63	61	61	61	58	52
	3V	44	<b>55</b>	56	52	53	51	46	40

# Water Cooled air conditioner

## Performance Data



### SOUND PRESSURE LEVELS (SPL) WITHIN A ROOM

Deduct the room absorption effect below from Sound Power Levels (SWL) to obtain Sound Pressure Levels within a room.

**Note:** Occupant at least 1.5 m from sound source.

Room type	OCTAVE BAND FREQUENCY Hz					
	125	250	500	1K	2K	4K
	ROOM ABSORPTION EFFECT					
Soft	4	8	11	11	11	11
Medium	3	7	8	9	9	9
Hard	0	1	3	4	4	5

# Water Cooled air conditioner

## Dimensions (mm)



### CWP 90RELSFY-S2

Allow adequate room in front of the unit for the filter to be removed for cleaning and for electrical box access.. The installation space must be ventilated at base level..

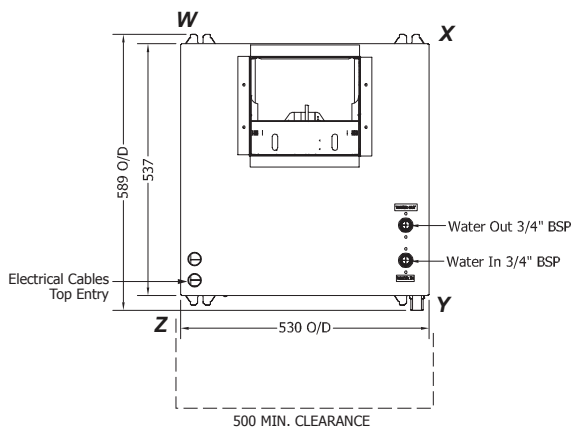
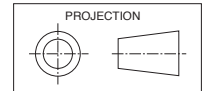

POINT LOADS (kg)			
W	X	Y	Z
28	18	24	20

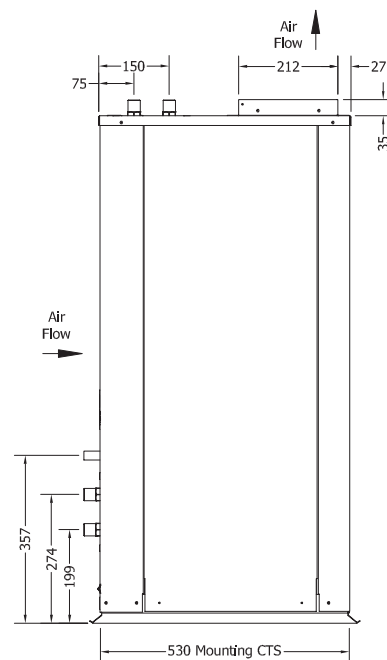
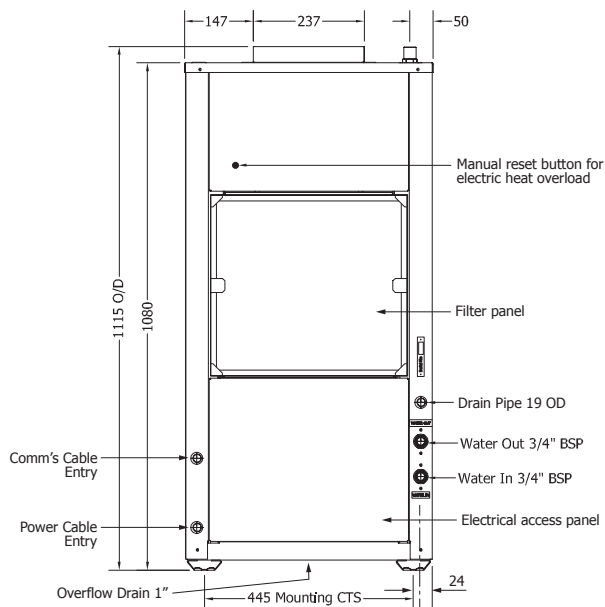

NOT TO SCALE

Materials and specifications are subject to change without notice due to the manufacturer's ongoing research and development programme.

# Water Cooled air conditioner

## Specifications



Eco Ultra Model	CWP90RELSFY-S2
Cooling Capacity Range (gross) kW	4.1 ~ 10.0
Nominal Cooling Capacity * <sup>1</sup> kW	10
Net Cooling Capacity (MEPS) kW	9.9
EER / AEER (cooling)	3.80 / 3.74
Heating Capacity Range kW	3.7 ~ 8.9
Heating Capacity * <sup>2</sup> kW	8.9
COP / ACOP (heating)	3.69 / 3.63
Electric Heat Option CWP-CE kW	3
Air Flow * <sup>3</sup> l/s	375 (200~425)
Power Source * <sup>4</sup>	1 phase 230V a.c. 50 Hz
Running Current A	10.5
Max. Running Current A	14
Refrigerant	R32
Nominal Water Flow * <sup>5</sup> l/s	0.6
Minimum Water Flow * <sup>6</sup> l/s	0.17
Water Coil Pressure Drop* <sup>7</sup> kPa (psi)	62 (9)
Unit Controller	UC8
Filter (EU2/G2 rated) * <sup>8</sup>	supplied
Weight (net) kg	90
Weight - incl. water kg	92

\*<sup>1</sup> Nominal Cooling Capacity at AS/NZS 3823.1.3 conditions:

Entering Water Temperature 30°C;  
Entering Air Temperature 27°C D.B., 19°C W.B.

\*<sup>2</sup> Heating Capacity (CWP\*R version only) at AS/NZS 3823.1.3 conditions:

Entering Water Temperature 20°C;  
Entering Air Temperature 20°C D.B.

\*<sup>3</sup> Air flows at nominal conditions above.

\*<sup>4</sup> Voltage fluctuation limits: Single phase systems 200–252 V; Three phase systems 342–436 V

\*<sup>5</sup> Nominal water flow at EWT - LWT = 5k.

\*<sup>6</sup> At nominal Entering Water Temperature: 30°C on cooling, 20°C on heating.

\*<sup>7</sup> At nominal water flow.

\*<sup>8</sup> Complies with AS 1668.2-2.5:2012.

\*<sup>9</sup> Heating mode.



Materials and specifications are subject to change without notice due to the manufacturer's ongoing research and development programme.



---

www.temperzone.biz

---

**AUCKLAND**

**Head Office**

38 Tidal Rd, Mangere, N.Z.  
Private Bag 93303, Otahuhu,  
NEW ZEALAND.

Email [sales@temperzone.co.nz](mailto:sales@temperzone.co.nz)

Phone (09) 279 5250

Fax (09) 275 5637

**SYDNEY**

**Head Office**

14 Carnegie Place, Blacktown,  
NSW 2148  
PO Box 8064, Seven Hills West,  
NSW 2147, AUSTRALIA.

Email [sales@temperzone.com.au](mailto:sales@temperzone.com.au)

Phone (02) 8822 - 5700

Fax (02) 8822 - 5711

**NEWCASTLE**

Phone (02) 4962 - 1155

Fax (02) 4961 - 5101

**LAUNCESTON**

Phone (03) 6331 - 4209

Fax (03) 6333 - 0224

**WELLINGTON**

Phone (04) 569 3262

Fax (04) 566 6249

**ADELAIDE**

Phone (08) 8115 - 2111

Fax (08) 8115 - 2118

**JAKARTA**

Phone +62 (21) 2963 4983

Fax +62 (21) 2963 4984

**CHRISTCHURCH**

Phone (03) 379 3216

Fax (03) 379 5956

**MELBOURNE**

Phone (03) 8769 - 7600

Fax (03) 8769 - 7601

**SINGAPORE**

Phone +65 6733 4292

Fax +65 6235 7180

**BRISBANE**

Phone (07) 3308 - 8333 or  
1800 - 897 - 253

Fax (07) 3308 - 8330

**SHANGHAI**

Phone +86 (21) 5648 2078

**PERTH**

Phone (08) 6399 - 5900

Fax (08) 6399 - 5932



Available from