

Air Handling Unit (345-360-XYZ / 345-365-000) ¹	MT 360	
Nominal Air Volume ²	10 000 l/s	
Nominal Cooling Capacity ³	4 row	225 kW
	6 row	295 kW
	8 row	335 kW
Nominal Heating Capacity ⁴	1 row	216 kW
	2 row	363 kW
Fan type	EC plug (x3)	
Fan motor size (3ph.)	3500 W / 630 mm dia.	
Unit Max. running amps (total)	17.1 A /ph.	
Protection Rating	IP4X	
Power supply ⁵	3 ph. 400 V ac 50 Hz + N + E	
RCD type recommended	type A, 30 mA, 3 pole	
Net weight – fan coil section	798 – 817 kg ⁶	
Net weight – plenum section – bare	346 kg	
Net weight – plenum section – damper mix	362 kg	
Shipping weight – fan coil section	889 – 1202 kg ⁶	
Shipping weight – plenum section – bare	419 kg	
Shipping weight – plenum section – damper mix	435 kg	

Accessories:

Filter - rated EU4/G4 disposable	019-000-158 594 x 594 x 44 (x12)
Filter - rated EU4/G4 washable	019-400-140 594 x 594 x 46 (x12)
Filter - rated F7 bag type	019-400-153 592 x 592 x 600 (x12)
Filter - rated F9 cartridge type	019-400-160 592 x 592 x 292 (x12)

Optional:

Chilled water coil 1/2"	4 / 6 / 8 row
Hot water coil 1/2"	1 / 2 row

Refer to temperzone for other options, eg remote sensors

¹ X = cooling coil rows, Y = heating coil rows and Z = handing. (Fan Coil Section / Plenum Section {bare})

² Based on 2.5 m/s coil face velocity

³ Cooling at nominal air flow, EAT 27 °C db / 19 °C wb, EWT 6°C, LWT 13°C.

⁴ Heating at nominal air flow, EAT 15 °C, EWT 80°C, LWT 60°C.

⁵ Voltage range: 380–440V

⁶ Depending on coil configuration; refer table page 2

DIMENSIONS (mm)



MT 360 Complete Air Handling Unit

Not to Scale

Pipe Connections
1/2" male BSP

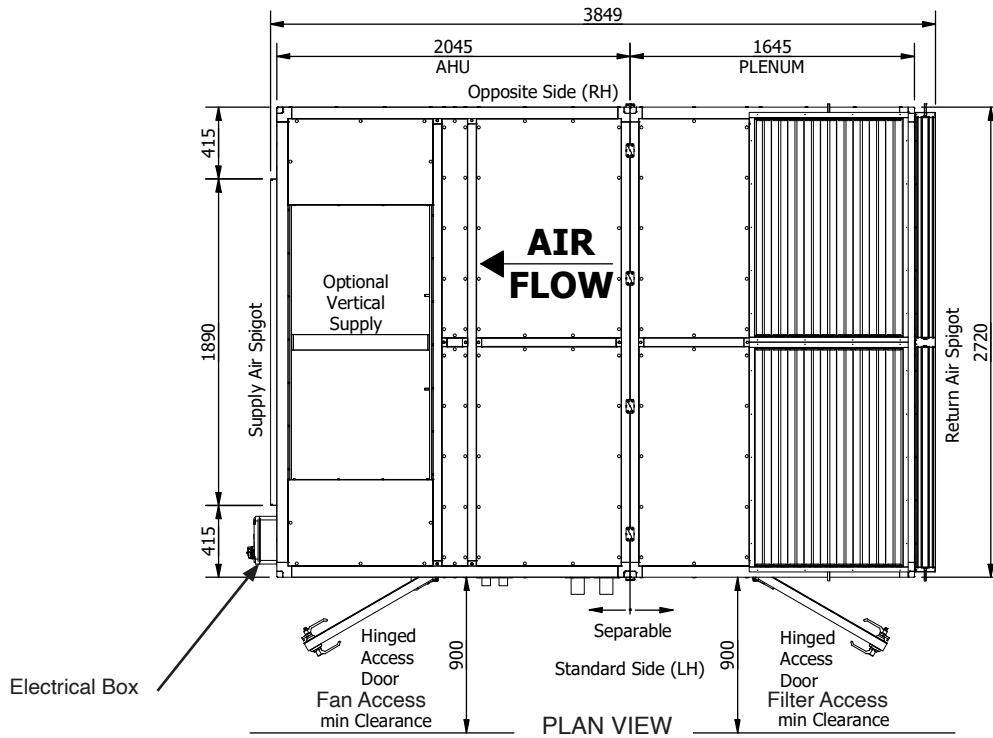

MT 360 Fan Coil Section

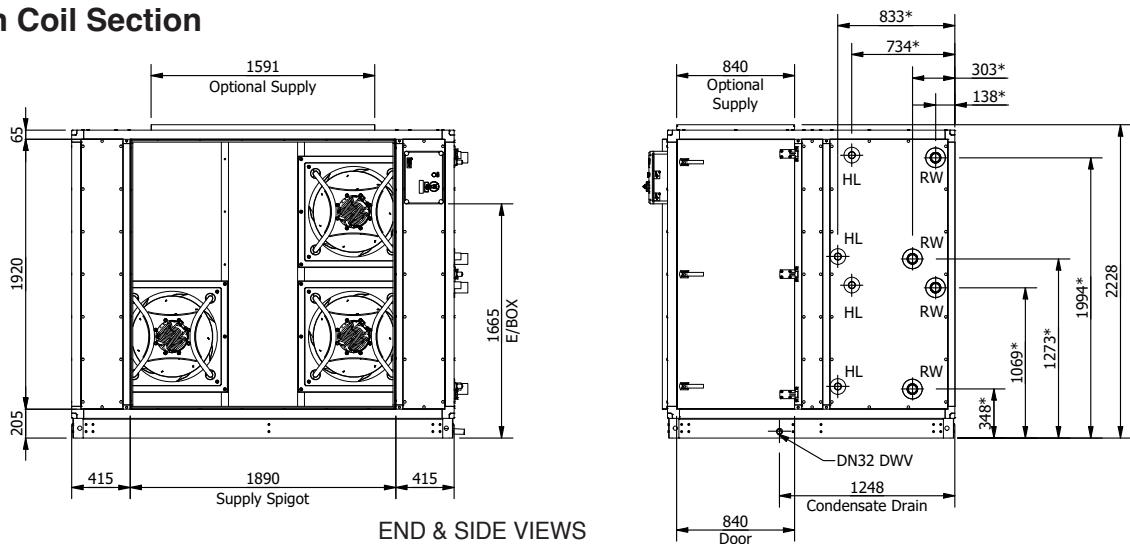

MT 360 Plenum Section

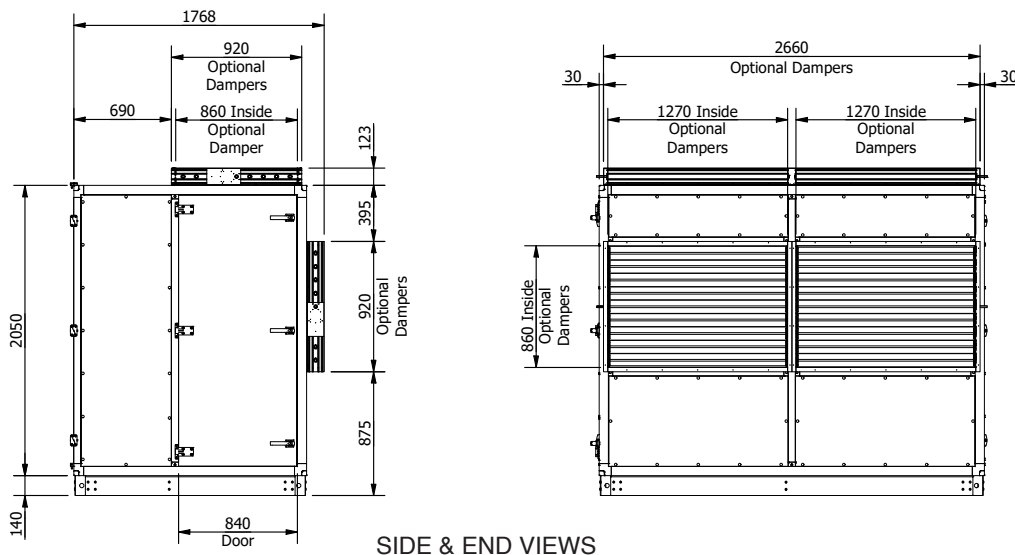

NOTE

Specifications are subject to change without notice due to the manufacturer's ongoing research and development programme.

WIRING

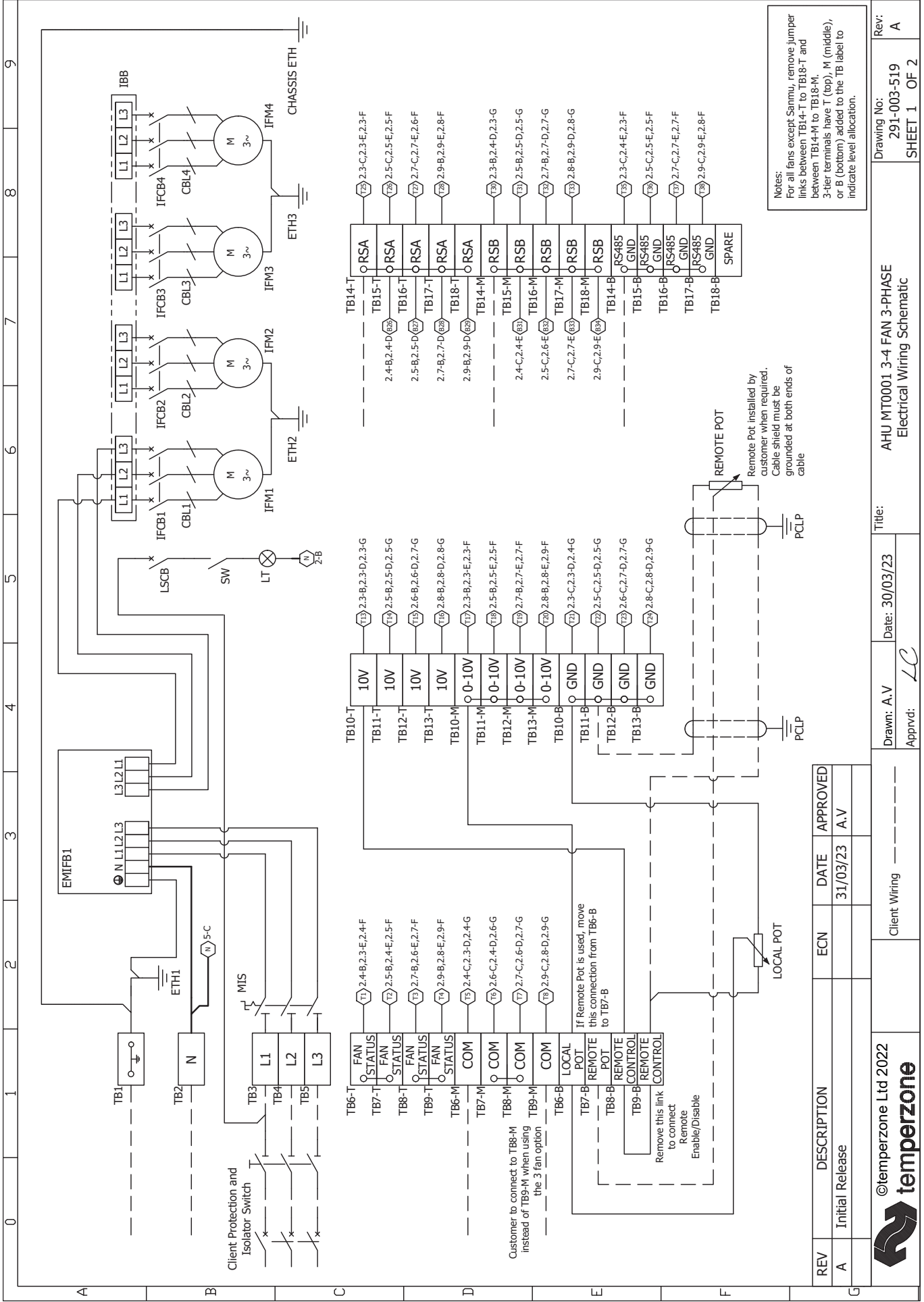

Notes:
For all fans except Sanmu, remove jumper links between TB14-T to TB18-T and between TB14-M to TB18-M. 3-tier terminals have T (top), M (middle), or B (bottom) added to the TB label to indicate level allocation.

Remote Pot installed by customer when required. Cable shield must be grounded at both ends of cable

REV	DESCRIPTION	ECN	DATE	APPROVED
A	Initial Release		31/03/23	A.V



©temperzone Ltd 2022

Client Wiring

Drawn: A.V
Approved: LC

Date: 30/03/23

Title: AHU MT0001 3-4 FAN 3-PHASE
Electrical Wiring Schematic

Rev: 291-003-519
SHEET 1 OF 2

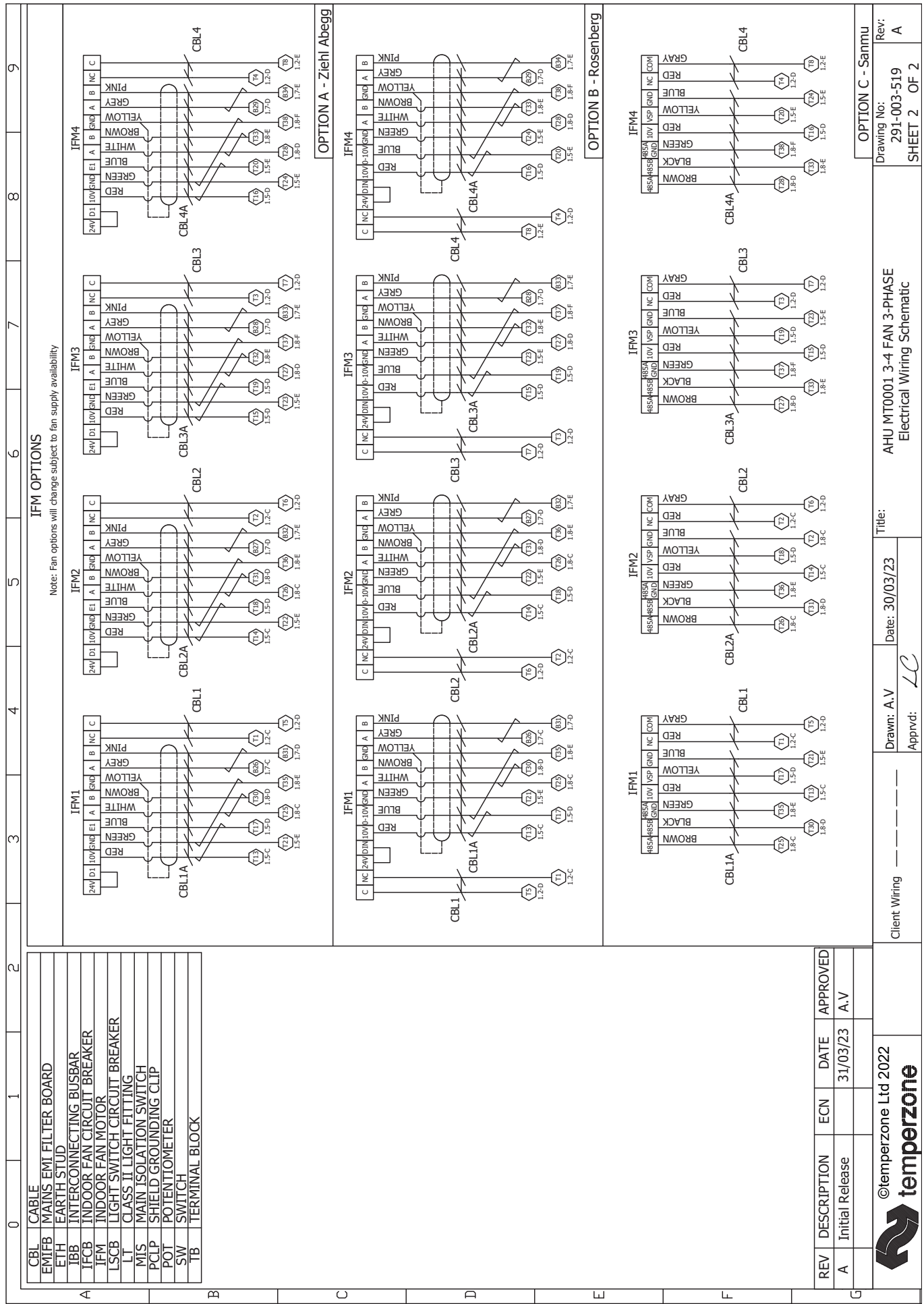

IFM OPTIONS

Note: Fan options will change subject to fan supply availability

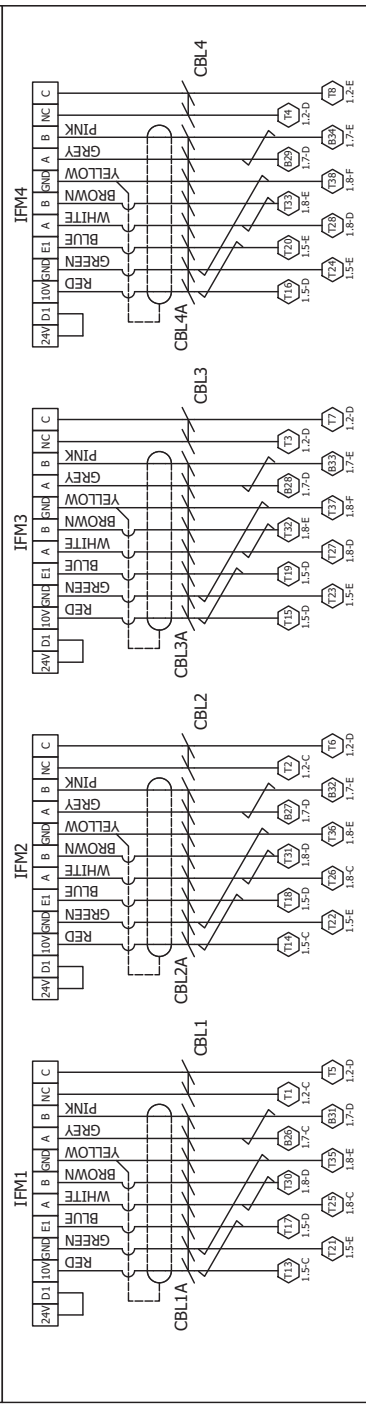

OPTION A - Ziehl Abegg

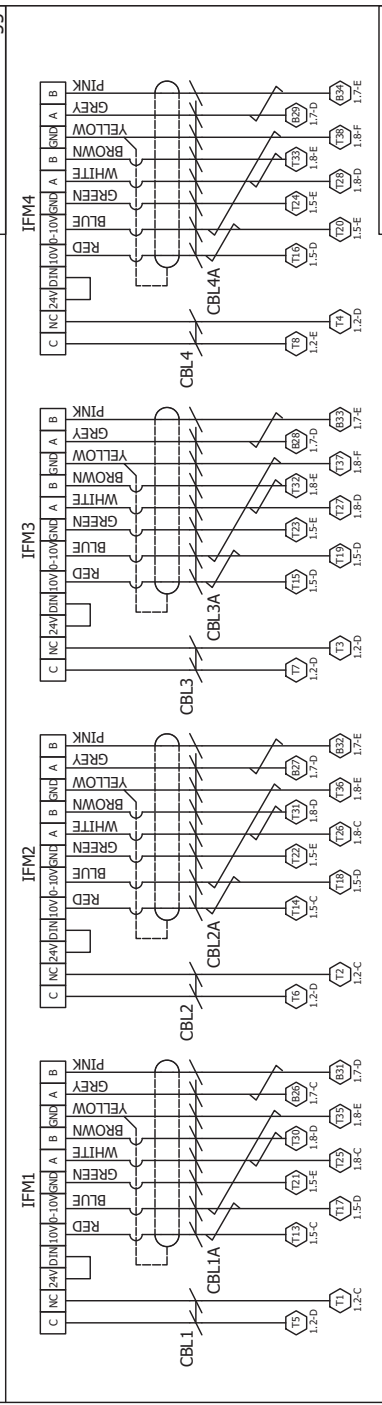

OPTION B - Rosenberg

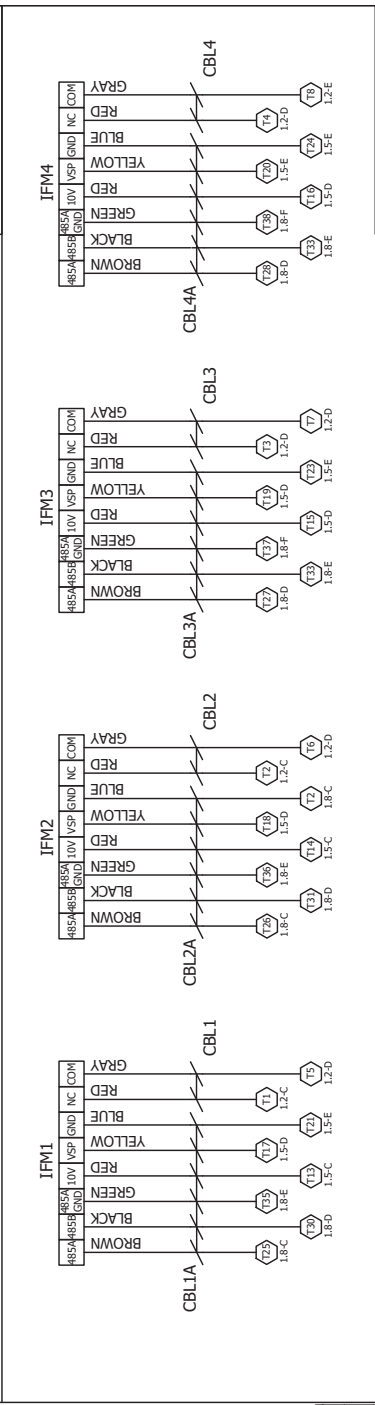

OPTION C - Sanmu

CBL	CABLE
EMIFB	MAINS EMI FILTER BOARD
ETH	EARTH STUD
IBB	INTERCONNECTING BUSBAR
IFCB	INDOOR FAN CIRCUIT BREAKER
IFM	INDOOR FAN MOTOR
LSCB	LIGHT SWITCH CIRCUIT BREAKER
LT	CLASS II LIGHT FITTING
MIS	MAIN ISOLATION SWITCH
PCLP	SHIELD GROUNDING CLIP
POT	POTENTIOMETER
SW	SWITCH
TB	TERMINAL BLOCK

REV	DESCRIPTION	ECN	DATE	APPROVED
A	Initial Release		31/03/23	A.V

©temperzone Ltd 2022

Client Wiring: _____
 Drawn: A.V
 Date: 30/03/23
 Appvd: LC

Title: AHU MT0001 3-4 FAN 3-PHASE
 Electrical Wiring Schematic

Drawing No: 291-003-519
 SHEET 2 OF 2
 Rev: A