



Ducted Packaged Units

Technical Data

OPA 250, 350, 450, 560 Econex R32



Cooling Capacity
10.1kW – 64.8kW



Heating Capacity
6.5kW – 63.0kW



Packaged Rooftop Air Conditioners R32

OPA 250 – 560 Econex

OPA 250–560 LKT SERIES	
General	3
Applications	4
Features	
Lower GWP	4
User Friendly	4
Economy	4
Efficient	4
Performance	4
Air Flow Selection	4
Quiet	5
Durable	5
Easy Access	5
Inverter Compressor	5
Insulation	5
Control Option	5
Extended Capability	5
Safety Features	5
Self Diagnostics	6
Wiring	6
Configurations	6
Optional Equipment	6
Economiser	6

CONTROLS	
TZT-100 Controller (Optional)	7

PERFORMANCE DATA	
Cooling Capacity (kW)	8
Heating Capacity (kW)	12
Indoor Air Flow Correction Factors	11
Air Handling	13
Sound Levels	
Indoor Unit	14
Outdoor Unit	15

DIMENSIONS	
OPA 250	16
OPA 350	18
OPA 450	20
OPA 560	22
Accessories	24

SPECIFICATIONS	
	25

Other relevant documents:
 - Specification Sheets
 - Part Load Data
 - Installation & Maintenance



Overview brochure available



Packaged Rooftop Air Conditioners R32

OPA 250 – 560 Econex

The OPA provides a variable capacity reverse cycle (heat pump) packaged rooftop air conditioner designed and developed to comply with and exceed Minimum Energy Performance Standards (MEPS AS/NZS 3823). Each system has been successfully tested at 52°C ambient.





Packaged Rooftop Air Conditioners R32

OPA 250 – 560 Econex

Applications

These units have been specifically developed for air conditioning of light commercial and residential premises, e.g. offices, motels shops and homes. Suitable for applications using high proportions of fresh air (nb pre-heating on heating cycle may be required). Also suitable for VAV, close control and supply air temperature control.

Features

Lower GWP

Utilising R32 Refrigerant, Temperzone's Econex Packaged Units enable a 75-80% reduction of Global Warming Potential (GWP) per kW of cooling when compared to R410A units.

User Friendly

The air conditioning system is available with an optional TZT-100 Controller or Climate Touch Controller. These thermostats have been designed to maintain a high level of comfort for room occupants. Emphasis has been placed on providing controls that are easy to install and use – despite the sophisticated microprocessor system that runs it. Use of the Auto and Timer function settings allows you to “set it and forget it”.

Economy

Each OPA unit has a variable capacity compressor which uses less energy than alternative types of compressor.

Efficient

These units include high efficiency electronically commutated (EC) motors, for both indoor and outdoor air fans. Part load operation at low loads (75% airflow equates to 55% power use) using Temperzone algorithms. Each unit incorporates a high efficiency inverter compressor. Heat exchange coils use inner grooved (rifled) tube for better heat transfer.

Performance

The variable capacity inverter compressor technology can provide close comfort control of the room temperature. Each OPA unit has an extra boost capacity available for fast response when well away from set point at start-up, and an energy saving low capacity turn-down.

A dynamically balanced backward curved fan with a multi-speed EC motor enables fine tuning of the indoor unit to match the supply air requirements. These EC motor fans have a fully integrated speed control that enables soft starting. Fan speed can be stepped to your own requirements or continuously variable using a 0–10V DC control signal.

The system also includes a temperature sensing head pressure control which enables the system to compensate for outdoor ambient temperatures below 20°C on cooling cycle, and above 15°C on heating cycle.

Air Flow Selection

If the air returning to the indoor coil is regularly expected to be above 50%RH, then the coil face velocity should be limited to be 2.5 m/s or less.

High humidity levels can occur in tropical or subtropical conditions, and/or when heavily moisture laden fresh air is introduced. Consideration must always be given to selecting an air flow and face velocity that avoids water carry-over problems.

Applications using high proportions of fresh air should be referred to your nearest Temperzone sales office to establish the correct selection of units.



Packaged Rooftop Air Conditioners R32

OPA 250 – 560 Econex

Features

Quiet

Each integral high efficiency EC motor can vary from zero to full speed. This allows slow ramp up with no sudden noise change. The motor can be controlled to have the best air flow for the ducting and requirements as well as used for de-humidifying the space.

The outdoor coil design permits low fan speeds and hence low noise levels. The compressor is isolated in a built-in, insulated compartment to minimise noise. The indoor air section is also insulated for noise attenuation and to prevent exterior condensation.

Durable

The cabinet is constructed from high grade galvanised steel - polyester powder coated (colour Grey) for all weather protection (IP 44). External fasteners are marine grade SKT® coated steel. The units include a polyester powder coated drain tray. Heat exchange coils comprise aluminium corrugated plate fins on mechanically expanded rifled copper tube. Both the indoor and outdoor air coil fins are epoxy coated for extra protection in corrosive environments, e.g. salt laden sea air. Fan motor bearings are sealed for life so as not to incur regular maintenance. Coil protection guards protect against hail, accidental damage or vandalism.

Easy Access

These packaged outdoor units are typically installed on a rooftop, where maintenance access is relatively easy during operating hours. Service panels are hinged with turn locks for ease of access. Air filters are easily accessible through hinged door on the side of the unit.

Low Maintenance

Commissioning and maintenance costs are reduced through use of a fan that requires no pulley and belt adjustments or changes like traditional fans. Dust is discouraged from entering the electrical compartment through a positive pressure

balance created by the indoor air fan. A controlled outdoor section drainage system directs water to a drainage point and prevents ponding of water that could create a home for moss, mould and slime.

Inverter Compressor

Each high efficiency variable capacity inverter compressor is hermetically sealed, quiet running and supported on rubber mounts to minimise vibration. Inverter compressors provide the economy of part load performance.

Soft Starting

EC motors and inverter compressors are soft starting therefore have none of the problems associated with high inrush current.

Insulation

Closed cell foam insulation has been used in the indoor air section to ensure no particles are introduced into the air stream. Both indoor and outdoor chambers are insulated to prevent external condensation forming on the cabinet exterior. The insulation is foil faced and meets fire test standards AS 1530.3 (1989) and BS 476 parts 6 & 7.

Control Option

Commissioned air flow can be maintained through use of the supplied differential pressure transducer and controller (supplied by others) to compensate for varying duct static pressures caused by dirty filters or modulating dampers. Commissioning is made easier. The EC plug fan motor is controlled variably (within a restricted range, p11) by a 0–10 volt DC signal that can be supplied either by a BMS system, a sophisticated controller or Temperzone's optional TZT-100 Controller.

The systems' UC8 controller is BMS compatible with multi-unit control possible – either via digital and analogue signals or via Modbus. Refer to Temperzone for other protocols available.

Extended Capability

Inverters are particularly suitable for applications requiring high proportions of fresh air, VAV, close control. Supply air temperature control is also possible using BMS or other controls. Refer to Temperzone for capacity range variation options.

Safety Features

1. HP and loss of refrigerant protection.
2. Anti-rapid cycle timer and internal overload for compressor protection.
3. Circuit breaker control circuits.
4. Time-and-temperature controlled electronic de-ice switch prevents icing up of the outdoor coil during heating cycle.
5. Frost protection on cooling cycle.
6. Sensor fault indication.
7. Compressor minimum run time to ensure oil return.
8. 12V control circuit.

Note: Consideration must be given to the minimum floor area requirements of R32 refrigerant.

Self Diagnostics

The Unit Controller (UC8) has a LED display to indicate faults and running conditions. A non-specific fault indicator is included for interface to external systems via the optional relay board.



Packaged Rooftop Air Conditioners R32

OPA 250 – 560 Econex

Features

Wiring

The electrical supply required (including voltage fluctuation limits) is:
3 phase 376–440 V a.c. 50 Hz with neutral and earth.

The compressor crankcase heater requires a 24hr power supply

The control panel is fully wired ready to accept the main power supply. Each system complies with the requirements of the Regulatory Compliance Mark (RCM) for electrical safety (AS/NZS 60335.2.40) and EMC (AS/NZS CISPR.14).

For your convenience, a single phase auxiliary power outlet (10A) is included in the electrical box.

Provision has been made for compliance with DRED, ie demand response enabling device standard AS/NZS 4755.3.1.

Plant Room Use

Each unit is supplied with a high static (125+ Pa) condenser fan. Nominal outdoor airflow, correct unit clearances and no air recirculation must be maintained in order for the unit to achieve its performance specification.

Configurations

1. Horizontal supply & return air versions
2. Downward supply & return air versions
3. Opposite hand versions of the above.

Optional Equipment

4. Filters (G4) rated to AS1324.1.2001 - disposable or washable, 50 or 100 mm thick.
5. Drain tundish connection kits – pack of 2 (pn 060-000-653).
6. Factory fitted economiser -includes dampers, fresh air cowl.
7. Electronic control systems (available by arrangement) for temperature and economy cycle.
8. Factory fitted adjustable fresh air damper and cowl.
9. Interface to BACnet/IP networks.

Economiser option

(Controls by Temperzone or others)

If the outdoor air heat content or wet bulb temperature (dry bulb not recommended) is below that of the return air, the fresh air damper opens and the return air damper closes to provide the first stage of cooling. Operating costs are reduced as free cooling is obtained. (Note: A spill air facility in the building may be necessary for when the return air damper is closed.) Fresh air dampers close to a minimum setting and return air dampers open before normal compressor operation resumes.

Temperzone offers a factory fitted Economiser control package, if required.

Dust Protection option

The compressor/electrical compartment can be pressurised with indoor supply air. This assists in keeping dust out of the compartment.



Packaged Rooftop Air Conditioners R32

Controls

TZT-100 Controller (Optional)



Features

- Cool / Cool Dry / Heat / Auto Dry / Auto / Fan Only modes.
- Auto / High / Medium / Low fan speed selection. (customisable).
- Temperature setting range from 1°C – 38°C.
- LED to indicate status of the unit [Power On/Off].
- Room & set temperature display.
- Real time clock.
- 12 or 24 hour time display
- °C or °F display
- **7 day timer** – up to two events (four start and/or stops per day)
- On demand countdown run timer, up to 9 hours.
- Auto-Restart or No Restart after power failure
- Continuous or Intermittent selection of fan run-on in dead zone.
- Backlit screen for ease of reading;
- Soft touch tab keys
- PIN protected menus (Installer PIN)
- Keypad and/or temperature lock
- Filter monitor option (by hours)
- Occupancy sensor inputs
- Integrated Modbus option
- Battery backup (Lithium).
- **Sleep function** – improves night time comfort and saves energy.
- Audible beep to acknowledge key entry or wireless remote control.
- 24V control cable.
- Optional remote air temperature sensor

Optional:

Remote return air sensor

For more information visit www.temperzone.biz; model search 'TZT-100'



Packaged Rooftop Air Conditioners R32

Performance Data

Cooling Capacity (kW)

- TC** = Total Capacity (kW)
- SC** = Sensible Capacity (kW)
- PI** = Power Input (kW)
- EAT** = Entering Air Temperature
- = Nominal Capacity (kW)

Nominal Air Flow: **1250 l/s**

Note: Capacities are **gross** and do not include allowance for fan motor heat loss.

OPA 250 Econex @Nominal Capacity (1250 l/s)

Indoor coil
E.A.T.

Outdoor coil Entering Air Temperature °C DB

D.B. °C	W.B. °C	23			27			31			35			39			43		
		TC	SC	PI	TC	SC	PI	TC	SC	PI	TC	SC	PI	TC	SC	PI	TC	SC	PI
21	14	23.3	18.0	6.1	22.8	18	6.5	22.4	18.1	6.9	21.8	18	7.4	21.3	17.9	7.9	20.7	17.8	8.5
	15	24.1	16.6	6.2	23.6	16.6	6.6	23.1	16.6	7.0	22.6	16.5	7.5	22	16.4	8.0	21.4	16.2	8.5
	16	25	14.9	6.2	24.5	14.9	6.6	23.9	14.8	7.1	23.4	14.7	7.5	22.8	14.6	8.0	22.1	14.4	8.6
	17	25.8	13.1	6.3	25.3	13.0	6.7	24.8	12.9	7.1	24.2	12.8	7.6	23.6	12.6	8.1	22.9	12.4	8.7
23	15	24	19.5	6.2	23.5	19.5	6.6	23	19.6	7.0	22.5	19.6	7.5	21.9	19.5	8.0	21.3	19.3	8.5
	16	24.7	18.1	6.2	24.2	18.2	6.6	23.7	18.1	7.0	23.2	18.1	7.5	22.6	18.0	8.0	21.9	17.8	8.6
	17	25.6	16.7	6.3	25.1	16.7	6.7	24.5	16.6	7.1	24.0	16.5	7.6	23.3	16.4	8.1	22.7	16.2	8.7
	18	26.5	15.0	6.3	25.9	15.0	6.7	25.4	14.9	7.2	24.8	14.8	7.6	24.1	14.6	8.2	23.4	14.4	8.7
27	18	26.3	21.1	6.3	25.8	21.2	6.7	25.2	21.3	7.2	24.6	21.2	7.6	24.0	21.2	8.2	23.3	21	8.7
	19	27.1	19.9	6.4	26.5	19.9	6.8	26	19.9	7.2	25.4	19.9	7.7	24.7	19.8	8.2	24.0	19.6	8.8
	20	27.9	18.5	6.4	27.3	18.5	6.8	26.7	18.4	7.3	26.1	18.4	7.8	25.4	18.3	8.3	24.7	18.1	8.9
	22	29.5	15.0	6.5	28.9	15.0	6.9	28.2	14.9	7.4	27.5	14.7	7.9	26.8	14.6	8.4	26.1	14.4	9.0
31	21	28.9	22.9	6.5	28.3	23.0	6.9	27.7	23.1	7.3	27.0	23.1	7.8	26.4	23.0	8.4	25.6	22.8	8.9
	22	29.6	21.6	6.5	29.0	21.7	6.9	28.3	21.7	7.4	27.7	21.7	7.9	27.0	21.6	8.4	26.2	21.5	9.0
	23	30.3	20.2	6.6	29.6	20.2	7.0	29.0	20.2	7.4	28.3	20.2	7.9	27.6	20.1	8.5	26.8	19.9	9.0
	25	31.8	16.9	6.6	31.1	16.9	7.1	30.4	16.8	7.5	29.7	16.7	8.0	29.0	16.6	8.6	28.1	16.4	9.2



Packaged Rooftop Air Conditioners R32

Performance Data

Cooling Capacity (kW)

- TC = Total Capacity (kW)
- SC = Sensible Capacity (kW)
- PI = Power Input (kW)
- EAT = Entering Air Temperature
- = Nominal Capacity (kW)

Nominal Air Flow: **1800 l/s**

Note: Capacities are **gross** and do not include allowance for fan motor heat loss.

OPA 350 Econex @Nominal Capacity (1800 l/s)

Indoor coil E.A.T.		Outdoor coil Entering Air Temperature °C DB																	
D.B. °C	W.B. °C	23			27			31			35			39			43		
		TC	SC	PI	TC	SC	PI	TC	SC	PI	TC	SC	PI	TC	SC	PI	TC	SC	PI
21	14	33.0	25.2	8.8	32.3	25.3	9.4	31.6	25.3	10.0	30.9	25.3	10.7	30.2	25.2	11.4	29.4	25.0	12.2
	15	34.1	23.2	8.8	33.5	23.2	9.4	32.7	23.2	10.1	32.0	23.1	10.8	31.2	22.9	11.5	30.4	22.8	12.3
	16	35.3	20.9	8.8	34.6	20.8	9.5	33.9	20.7	10.2	33.1	20.6	10.9	32.3	20.4	11.6	31.4	20.2	12.4
	17	36.5	18.2	8.9	35.8	18.1	9.5	35.0	18.0	10.2	34.2	17.8	10.9	33.4	17.6	11.7	32.5	17.3	12.5
23	15	34.0	27.3	8.8	33.3	27.4	9.4	32.6	27.4	10.1	31.8	27.4	10.8	31.1	27.3	11.5	30.2	27.2	12.3
	16	35.0	25.3	8.8	34.3	25.4	9.5	33.6	25.4	10.1	32.8	25.3	10.8	32.0	25.2	11.6	31.1	25.1	12.4
	17	36.2	23.3	8.9	35.5	23.3	9.5	34.7	23.2	10.2	33.9	23.1	10.9	33.1	23.0	11.7	32.2	22.8	12.5
	18	37.4	20.9	8.9	36.7	20.9	9.6	35.9	20.8	10.3	35.1	20.6	11.0	34.2	20.4	11.8	33.3	20.2	12.6
27	18	37.3	29.6	8.9	36.5	29.7	9.6	35.7	29.8	10.3	34.9	29.8	11.0	34.0	29.7	11.8	33.1	29.5	12.6
	19	38.3	27.8	8.9	37.6	27.9	9.6	36.8	27.9	10.3	35.9	27.9	11.1	35.0	27.8	11.8	34.0	27.6	12.6
	20	39.4	25.8	9.0	38.6	25.8	9.7	37.8	25.8	10.4	36.9	25.7	11.1	36.0	25.6	11.9	35.0	25.4	12.7
	22	41.7	20.9	9.0	40.9	20.9	9.7	40.0	20.7	10.5	39.0	20.6	11.2	38.0	20.4	12.1	37.0	20.1	12.9
31	21	40.9	32.1	9.0	40.1	32.3	9.7	39.2	32.4	10.4	38.3	32.4	11.2	37.3	32.3	12.0	36.3	32.1	12.8
	22	41.9	30.3	9.0	41.1	30.4	9.7	40.2	30.5	10.5	39.2	30.4	11.3	38.2	30.3	12.1	37.2	30.1	12.9
	23	42.9	28.3	9.1	42.0	28.3	9.8	41.1	28.3	10.5	40.1	28.3	11.3	39.1	28.1	12.1	38.0	27.9	13.0
	25	45.1	23.6	9.1	44.2	23.6	9.9	43.2	23.5	10.6	42.2	23.3	11.4	41.1	23.2	12.3	39.9	22.9	13.1



Packaged Rooftop Air Conditioners R32

Performance Data

Cooling Capacity (kW)

- TC = Total Capacity (kW)
- SC = Sensible Capacity (kW)
- PI = Power Input (kW)
- EAT = Entering Air Temperature
- = Nominal Capacity (kW)

Nominal Air Flow: **2200 l/s**

Note: Capacities are **gross** and do not include allowance for fan motor heat loss.

OPA 450 Econex @Nominal Capacity (2200 l/s)

Indoor coil
E.A.T.

Outdoor coil Entering Air Temperature °C DB

D.B. °C	W.B. °C	23			27			31			35			39			43		
		TC	SC	PI	TC	SC	PI	TC	SC	PI	TC	SC	PI	TC	SC	PI	TC	SC	PI
21	14	41.4	31.9	11.5	40.6	32.0	12.3	39.7	32.0	13.1	38.7	31.9	14.0	37.7	31.7	15.0	36.6	31.4	16.0
	15	42.9	29.4	11.5	42.0	29.4	12.3	41.1	29.3	13.2	40.1	29.1	14.1	39.0	28.9	15.1	37.9	28.6	16.1
	16	44.4	26.5	11.6	43.5	26.4	12.4	42.5	26.3	13.3	41.4	26.1	14.3	40.4	25.8	15.2	39.2	25.5	16.3
	17	45.9	23.2	11.7	44.9	23.0	12.5	43.9	22.8	13.4	42.9	22.6	14.4	41.7	22.2	15.4	40.5	21.9	16.4
23	15	42.7	34.6	11.5	41.8	34.6	12.3	40.8	34.6	13.2	39.9	34.6	14.1	38.8	34.4	15.1	37.7	34.1	16.1
	16	43.9	32.1	11.6	43.0	32.2	12.4	42.1	32.1	13.3	41.0	32.0	14.2	40.0	31.8	15.2	38.8	31.5	16.2
	17	45.5	29.6	11.6	44.5	29.5	12.5	43.5	29.4	13.4	42.5	29.3	14.3	41.3	29.0	15.3	40.2	28.7	16.4
	18	47.0	26.6	11.7	46.0	26.5	12.6	45.0	26.3	13.5	43.9	26.1	14.4	42.7	25.8	15.4	41.5	25.5	16.5
27	18	46.8	37.5	11.7	45.8	37.6	12.6	44.8	37.7	13.5	43.7	37.6	14.4	42.5	37.4	15.4	41.3	37.1	16.5
	19	48.2	35.3	11.7	47.1	35.4	12.6	46.1	35.3	13.5	44.9	35.2	14.5	43.7	35.0	15.5	42.5	34.7	16.6
	20	49.6	32.8	11.8	48.5	32.8	12.7	47.4	32.7	13.6	46.2	32.5	14.6	45.0	32.3	15.6	43.7	32.0	16.7
	22	52.4	26.7	11.9	51.3	26.6	12.8	50.1	26.4	13.8	48.9	26.1	14.8	47.5	25.8	15.8	46.2	25.4	17.0
31	21	51.4	40.8	11.9	50.3	40.9	12.8	49.2	40.9	13.7	48.0	40.9	14.7	46.7	40.7	15.8	45.3	40.4	16.9
	22	52.6	38.5	11.9	51.5	38.6	12.8	50.3	38.6	13.8	49.1	38.4	14.8	47.8	38.2	15.9	46.4	37.9	17.0
	23	53.9	35.9	12.0	52.7	36.0	12.9	51.5	35.9	13.9	50.2	35.8	14.9	48.9	35.5	15.9	47.4	35.2	17.1
	25	56.6	30.1	12.0	55.4	30.0	13.0	54.1	29.9	14.0	52.8	29.6	15.0	51.3	29.3	16.1	49.8	28.9	17.3



Packaged Rooftop Air Conditioners R32

Performance Data

Cooling Capacity (kW)

- TC = Total Capacity (kW)
- SC = Sensible Capacity (kW)
- PI = Power Input (kW)
- EAT = Entering Air Temperature
- = Nominal Capacity (kW)

Nominal Air Flow: **2600 l/s**

Note: Capacities are **gross** and do not include allowance for fan motor heat loss.

OPA 560 Econex @Nominal Capacity (2600 l/s)

Indoor coil
E.A.T.

Outdoor coil Entering Air Temperature °C DB

D.B. °C	W.B. °C	23			27			31			35			39			43		
		TC	SC	PI	TC	SC	PI	TC	SC	PI	TC	SC	PI	TC	SC	PI	TC	SC	PI
21	14	51.2	38.6	14.2	50.2	38.7	15.2	49.1	38.7	16.2	48.0	38.6	17.3	46.8	38.4	18.5	45.5	38.2	19.8
	15	53.0	35.4	14.3	52.0	35.4	15.3	50.8	35.4	16.3	49.6	35.2	17.5	48.4	35.0	18.7	47.1	34.7	19.9
	16	54.9	31.8	14.3	53.7	31.7	15.4	52.6	31.6	16.5	51.3	31.4	17.6	50.0	31.1	18.8	48.7	30.7	20.1
	17	56.7	27.7	14.4	55.6	27.5	15.5	54.4	27.3	16.6	53.1	27.0	17.7	51.7	26.7	19.0	50.3	26.3	20.3
23	15	52.8	41.8	14.2	51.7	41.9	15.3	50.6	42.0	16.3	49.4	41.9	17.5	48.1	41.8	18.6	46.8	41.5	19.9
	16	54.3	38.8	14.3	53.2	38.8	15.3	52.1	38.8	16.4	50.8	38.7	17.6	49.6	38.5	18.8	48.2	38.2	20.0
	17	56.2	35.5	14.4	55.1	35.5	15.4	53.9	35.5	16.5	52.6	35.3	17.7	51.2	35.0	18.9	49.8	34.7	20.2
	18	58.1	31.9	14.4	56.9	31.8	15.5	55.7	31.6	16.6	54.3	31.4	17.8	53.0	31.1	19.1	51.5	30.7	20.4
27	18	57.8	45.4	14.4	56.7	45.5	15.5	55.4	45.6	16.6	54.1	45.6	17.8	52.7	45.4	19.0	51.2	45.1	20.3
	19	59.5	42.6	14.5	58.3	42.7	15.6	57.0	42.7	16.7	55.6	42.6	17.9	54.2	42.4	19.2	52.7	42.1	20.5
	20	61.2	39.4	14.6	59.9	39.4	15.6	58.6	39.4	16.8	57.2	39.2	18.0	55.7	39.0	19.3	54.2	38.7	20.6
	22	64.7	31.9	14.7	63.4	31.7	15.8	61.9	31.5	17.0	60.5	31.2	18.2	58.9	30.9	19.5	57.2	30.5	20.9
31	21	63.5	49.2	14.6	62.2	49.4	15.7	60.8	49.5	16.9	59.4	49.5	18.1	57.8	49.4	19.4	56.2	49.1	20.8
	22	65.0	46.4	14.7	63.7	46.5	15.8	62.2	46.6	17.0	60.7	46.5	18.2	59.2	46.3	19.5	57.5	46.0	20.9
	23	66.5	43.2	14.7	65.1	43.3	15.9	63.7	43.3	17.1	62.1	43.2	18.3	60.5	42.9	19.6	58.8	42.6	21.0
	25	69.9	36.0	14.8	68.4	35.9	16.0	66.9	35.7	17.2	65.3	35.5	18.5	63.5	35.2	19.9	61.7	34.8	21.3

Indoor Air Flow Correction Factors @ nominal conditions

Indoor Air Flow (%)

	-20	-10	Rated	+10
Total Capacity	0.95	0.975	1.0	1.025
Sensible Capacity	0.90	0.950	1.0	1.050



Packaged Rooftop Air Conditioners R32

Performance Data

Heating Capacity (kW)

G = Gross Capacity kW, based on nominal air flow.
 N = Net Heating Capacity kW allowing for average defrost.
 ○ = Nominal Capacity (kW).

OPA 250 at Nominal Capacity (1250 l/s)

Air on		Outdoor coil entering air temperature °C DB																							
D.B. °C	- 5			- 3			- 1			1			3			5			7			9			
	G	N	PI	G	N	PI	G	N	PI	G	N	PI	G	N	PI	G	N	PI	G	N	PI	G	N	PI	
15	20.2	17.7	7.0	21.4	17.5	7.1	22.6	17.8	7.3	23.7	18.9	7.3	24.9	21.4	7.3	26.0	25.4	7.4	27.2	27.2	7.5	28.3	28.3	7.7	
20	19.9	17.5	7.5	21.1	17.3	7.7	22.3	17.6	7.9	23.4	18.7	7.9	24.6	21.1	7.9	25.7	25.2	8.0	26.9	26.9	8.1	28.0	28.0	8.2	
25	19.3	17.0	8.1	20.5	16.8	8.3	21.6	17.0	8.5	22.8	18.2	8.5	23.9	20.6	8.5	25.1	24.7	8.6	26.2	26.2	8.8	27.4	27.4	8.9	

OPA 350 at Nominal Capacity (1800 l/s)

Air on		Outdoor coil entering air temperature °C DB																							
D.B. °C	- 5			- 3			- 1			1			3			5			7			9			
	G	N	PI	G	N	PI	G	N	PI	G	N	PI	G	N	PI	G	N	PI	G	N	PI	G	N	PI	
15	27.9	24.4	10.2	29.5	24.1	10.3	31.0	24.5	10.5	32.6	26.1	10.5	34.2	29.4	10.5	35.8	35.0	10.6	37.4	37.4	10.8	39.0	39.0	10.9	
20	27.5	24.1	10.9	29.0	23.8	11.0	30.6	24.2	11.2	32.2	25.8	11.3	33.8	29.1	11.2	35.4	34.7	11.4	37.0	37.0	11.5	38.6	38.6	11.7	
25	26.6	23.4	11.6	28.2	23.1	11.8	29.8	23.5	12.0	31.3	25.1	12.1	32.9	28.4	12.0	34.5	34.0	12.2	36.1	36.1	12.4	37.7	37.7	12.5	

OPA 450 at Nominal Capacity (2200 l/s)

Air on		Outdoor coil entering air temperature °C DB																							
D.B. °C	- 5			- 3			- 1			1			3			5			7			9			
	G	N	PI	G	N	PI	G	N	PI	G	N	PI	G	N	PI	G	N	PI	G	N	PI	G	N	PI	
15	33.5	29.3	12.6	35.4	28.9	12.8	37.3	29.4	13.0	39.2	31.3	13.1	41.1	35.3	13.0	43.0	42.1	13.2	44.9	44.9	13.3	46.8	46.8	13.5	
20	33.0	28.9	13.4	34.9	28.6	13.6	36.8	29.0	13.9	38.7	30.9	13.9	40.6	34.9	13.9	42.5	41.7	14.1	44.4	44.4	14.2	46.3	46.3	14.4	
25	31.9	28.1	14.3	33.8	27.7	14.5	35.7	28.2	14.8	37.6	30.1	14.9	39.5	34.1	14.8	41.5	40.8	15.0	43.4	43.4	15.2	45.3	45.3	15.4	

OPA 560 at Nominal Capacity (2600 l/s)

Air on		Outdoor coil entering air temperature °C DB																							
D.B. °C	- 5			- 3			- 1			1			3			5			7			9			
	G	N	PI	G	N	PI	G	N	PI	G	N	PI	G	N	PI	G	N	PI	G	N	PI	G	N	PI	
15	42.9	37.6	16.8	45.4	37.1	17.0	47.8	37.7	17.4	50.3	40.2	17.4	52.7	45.3	17.4	55.2	54.0	17.6	57.6	57.6	17.8	60.1	60.1	18.0	
20	42.3	37.1	17.9	44.7	36.6	18.2	47.2	37.2	18.6	49.6	39.7	18.6	52.1	44.8	18.6	54.5	53.5	18.8	57.0	57.0	19.1	59.4	59.4	19.3	
25	40.9	36.0	19.1	43.4	35.6	19.5	45.8	36.2	19.9	48.3	38.6	19.9	50.7	43.7	19.9	53.2	52.4	20.2	55.6	55.6	20.4	58.1	58.1	20.7	



Packaged Rooftop Air Conditioners R32

Performance Data

Air Handling

Airflows are for a dry coil. Reduce airflow by 10% in high moisture removal conditions. In a free blow application, beware of exceeding indoor fan motor's full load amp limit. Refer back page for filter losses. Air flows given are for OPA units without filters installed.

⬡ Amps

OPA 250

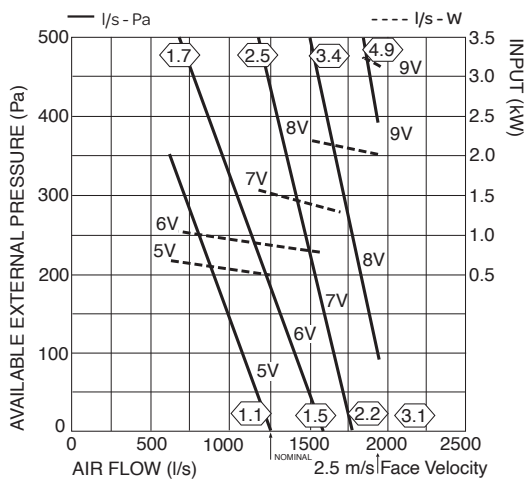

OPA 350

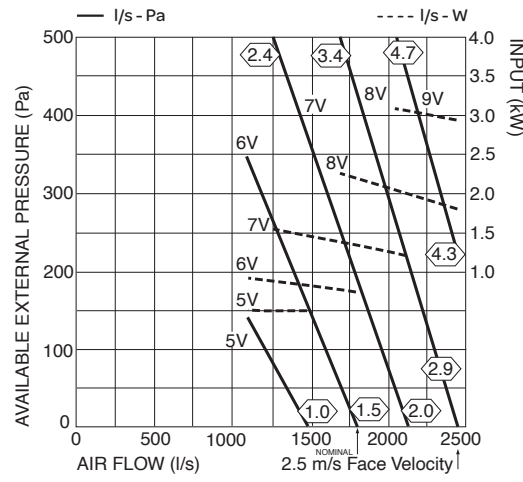

OPA 450

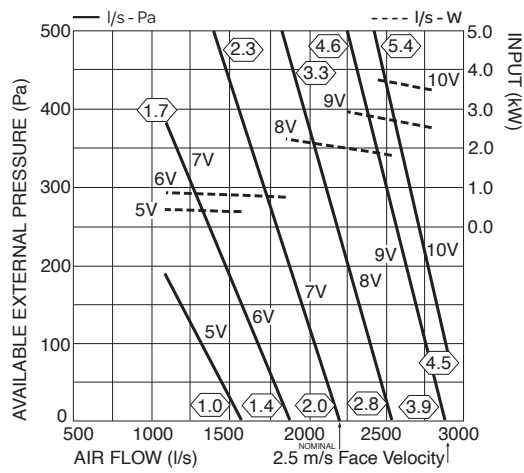

OPA 560

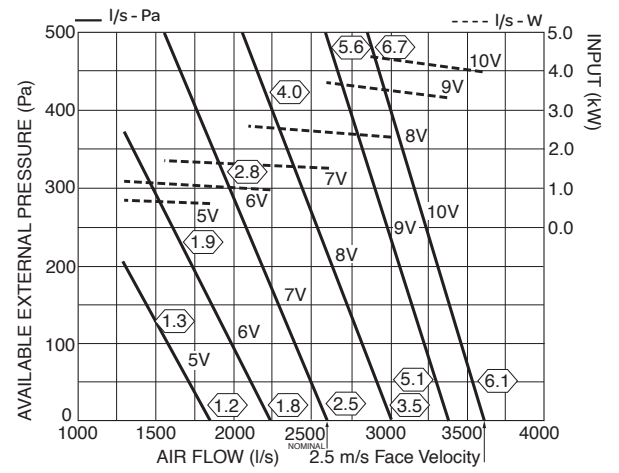

Filter Pressure Drop (optional Filters)

EU4/G4 rated filter media

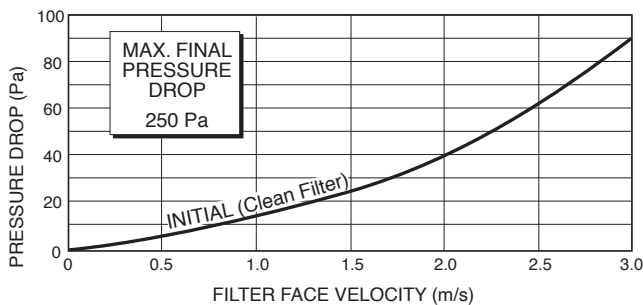



Packaged Rooftop Air Conditioners R32

Performance Data

Sound Levels – Indoor

Test Conditions: EN 12102-1:2017.
Diffuse field method in a reverberant room.
Measured in decibels re 1 picowatt.

Sound Power Levels (SWL) – Supply Air Outlet

Models	Fan Speed	Static (Pa)	SWL dB(A)	Octave Band Frequency Hz					
				125	250	500	1k	2k	4k
OPA 250	4 V	75	72	51	64	65	68	64	60
	5.5 V *	75	78	57	70	71	74	70	66
	10 V	75	88	67	80	81	84	80	76
OPA 350	4 V	85	72	63	64	65	67	63	58
	6.5 V *	85	80	71	72	73	75	71	66
	10 V	85	87	78	79	80	82	78	73
OPA 450	4 V	25	72	63	64	65	67	63	58
	7.5 *	85	84	75	76	77	79	75	70
	10 V	110	89	80	81	82	84	80	75
OPA 560	4 V	50	73	64	66	66	68	63	56
	7.5 V *	110	84	75	77	77	79	74	67
	10 V	300	91	82	84	84	86	81	74

* Note: Indoor Air fan running at nominal speed

Sound Pressure Levels (SPL) Within A Room

Deduct the room absorption effect below from the Sound Power Levels (SWL) above to obtain Sound Pressure Levels within a room.
Note: Occupant at least 1.5 m from sound source.

Room type	Octave Band Frequency Hz					
	125	250	500	1k	2k	4k
Soft	4	8	11	11	11	11
Medium	3	7	8	9	9	9
Hard	0	1	3	4	4	5



Packaged Rooftop Air Conditioners R32

Performance Data

Sound Levels – Outdoor

Sound Power Levels (SWL) – Radiated

Measured in decibels re 1 picowatt

Models	Fan Speed	SWL dB(A)	Octave Band Frequency Hz					
			125	250	500	1K	2K	4K
OPA 250	2.2V	66	54	56	58	61	59	57
	6V*	74	62	64	66	69	67	65
	10V	86	74	76	78	81	79	77
OPA 350	2.2V	66	54	56	58	61	59	57
	7V*	78	66	68	70	73	71	69
	10V	86	74	76	78	81	79	77
OPA 450	2.2V	69	54	58	63	64	63	57
	7V*	80	65	69	74	75	74	68
	10V	86	71	75	80	81	80	74
OPA 560	4V	69	54	58	63	64	63	57
	8V*	83	68	72	77	78	77	71
	10V	86	71	75	80	81	80	74

* Note: Outdoor fans running at nominal speed

Sound Pressure Levels (SPL)

Models	Fan Speed	SPL @ 3 m dB(A)	Sound Pressure Levels (SPL) dB					
			125	250	500	1K	2K	4K
OPA 250	2.2V	50	38	40	42	45	43	41
	6V*	58	46	48	50	53	51	49
	10V	70	58	60	62	65	63	61
OPA 350	2.2V	50	38	40	42	45	43	41
	7V*	62	50	52	54	57	55	53
	10V	70	58	60	62	65	63	61
OPA 450	2.2V	53	38	42	47	48	47	41
	7V*	64	49	53	58	59	58	52
	10V	70	55	59	64	65	64	58
OPA 560	4V	53	38	42	47	48	47	41
	8V*	67	52	56	61	62	61	55
	10V	70	55	59	64	65	64	58

Sound Pressure Level (SPL) in decibels re 20 µPa



Packaged Rooftop Air Conditioners R32

Dimensions (mm)

OPA 250RLTFPQ Horizontal Supply

		POINT LOADS (kg)			
		W	X	Y	Z
Std Hd	no F/A	104	149	100	158
	cw F/A	104	157	100	158
Op Hd	no F/A	121	155	91	144

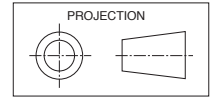

Not to Scale

Refer page 26 for
Optional Economiser Cowl
dimensions

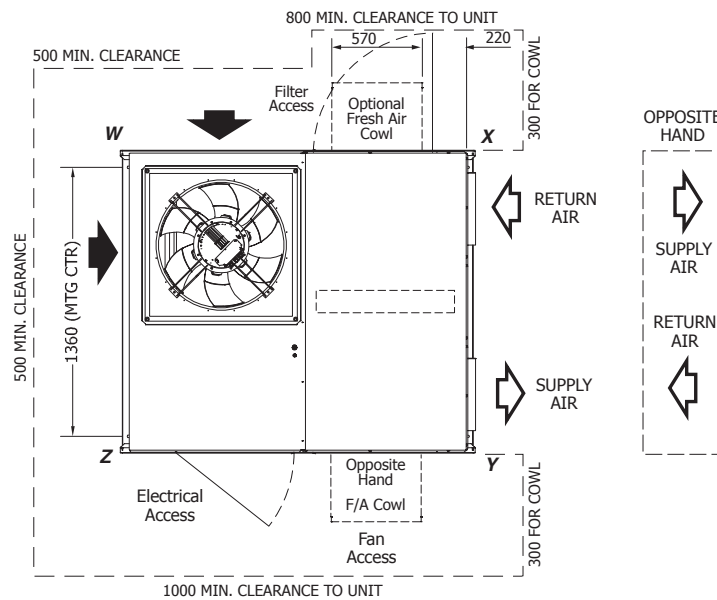

Multiple units side-by-side:
Allow a minimum of 1m
between coil faces.

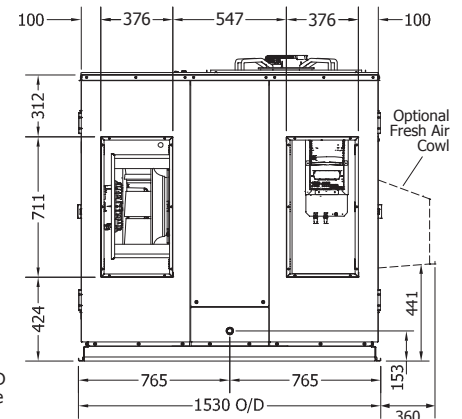
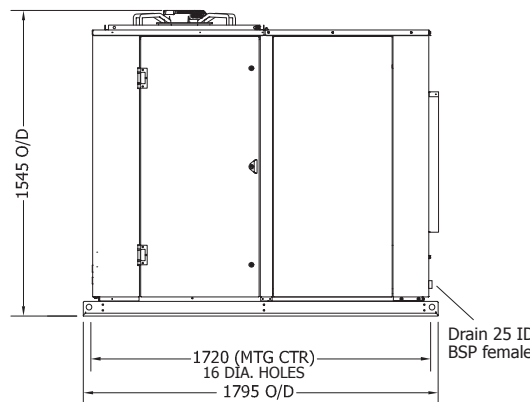
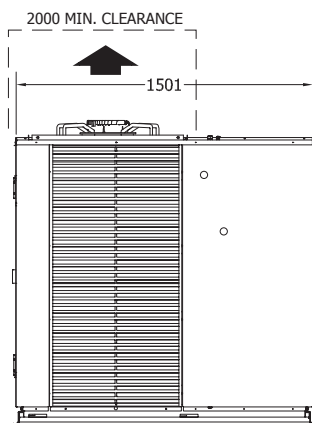

Materials and specifications are subject to change without notice due to the manufacturer's ongoing research and development programme.



Packaged Rooftop Air Conditioners R32

Dimensions (mm)

OPA 250RLTFPQ Downward Supply

		POINT LOADS (kg)			
		W	X	Y	Z
Std Hd	no F/A	104	149	100	158
	cw F/A	104	157	100	158
Op Hd	no F/A	121	155	91	144

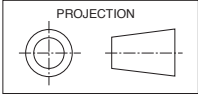

Not to Scale

Refer previous page for full dimensions

Multiple units side-by-side:
Allow a minimum of 1m between coil faces.

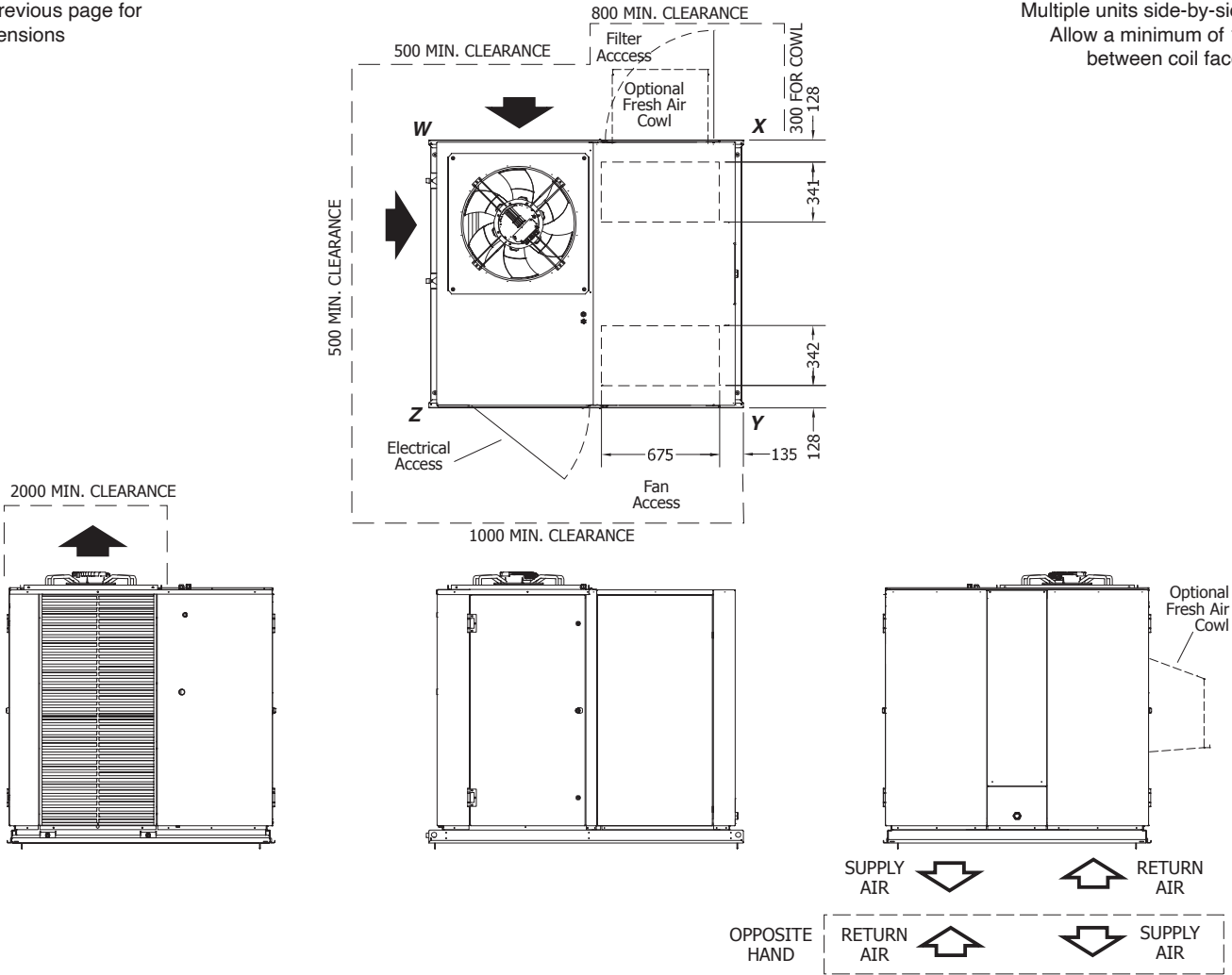

Materials and specifications are subject to change without notice due to the manufacturer's ongoing research and development programme.



Packaged Rooftop Air Conditioners R32

Dimensions (mm)

OPA 350RLTFPQ Horizontal Supply

		POINT LOADS (kg)			
		W	X	Y	Z
Std Hd	no F/A	164	133	153	146
	cw F/A	164	141	153	146
Op Hd	no F/A	159	152	132	153

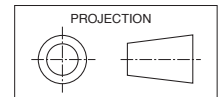

Not to Scale

Refer page 26 for
Optional Economiser Cowl
dimensions

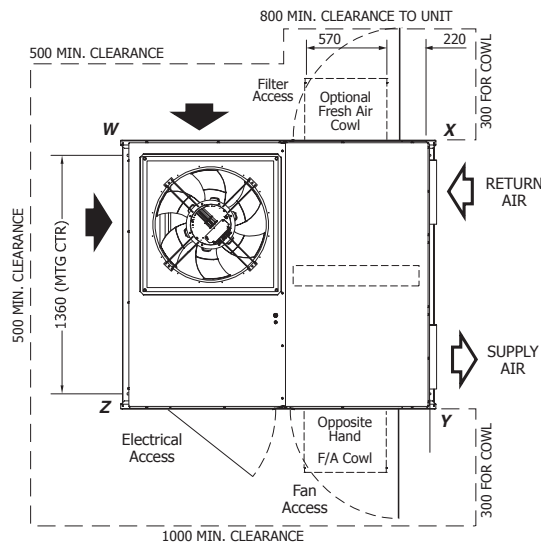

Multiple units side-by-side:
Allow a minimum of 1m
between coil faces.

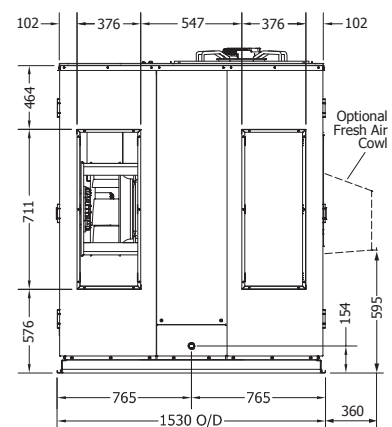
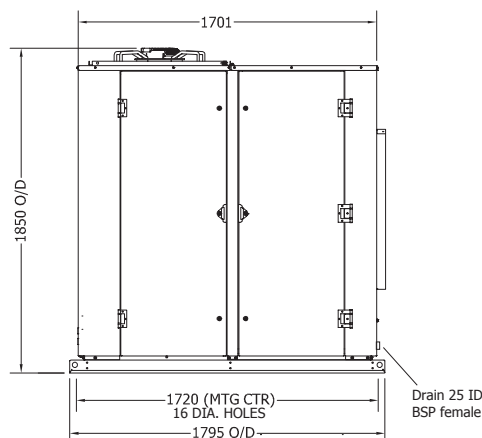
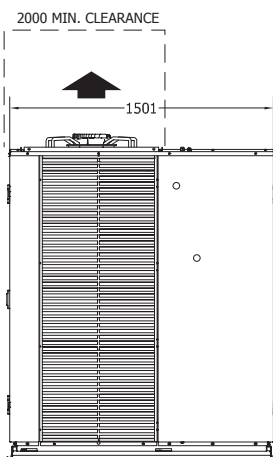

Materials and specifications are subject to change without notice due to the manufacturer's ongoing research and development programme.



Packaged Rooftop Air Conditioners R32

Dimensions (mm)

OPA 350RLTFPQ Downward Supply

		POINT LOADS (kg)			
		W	X	Y	Z
Std Hd	no F/A	164	133	153	146
	cw F/A	164	141	153	146
Op Hd	no F/A	159	152	132	153

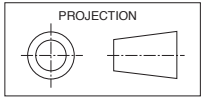

Not to scale

Refer previous page for full dimensions

Multiple units side-by-side:
Allow a minimum of 1m
between coil faces.

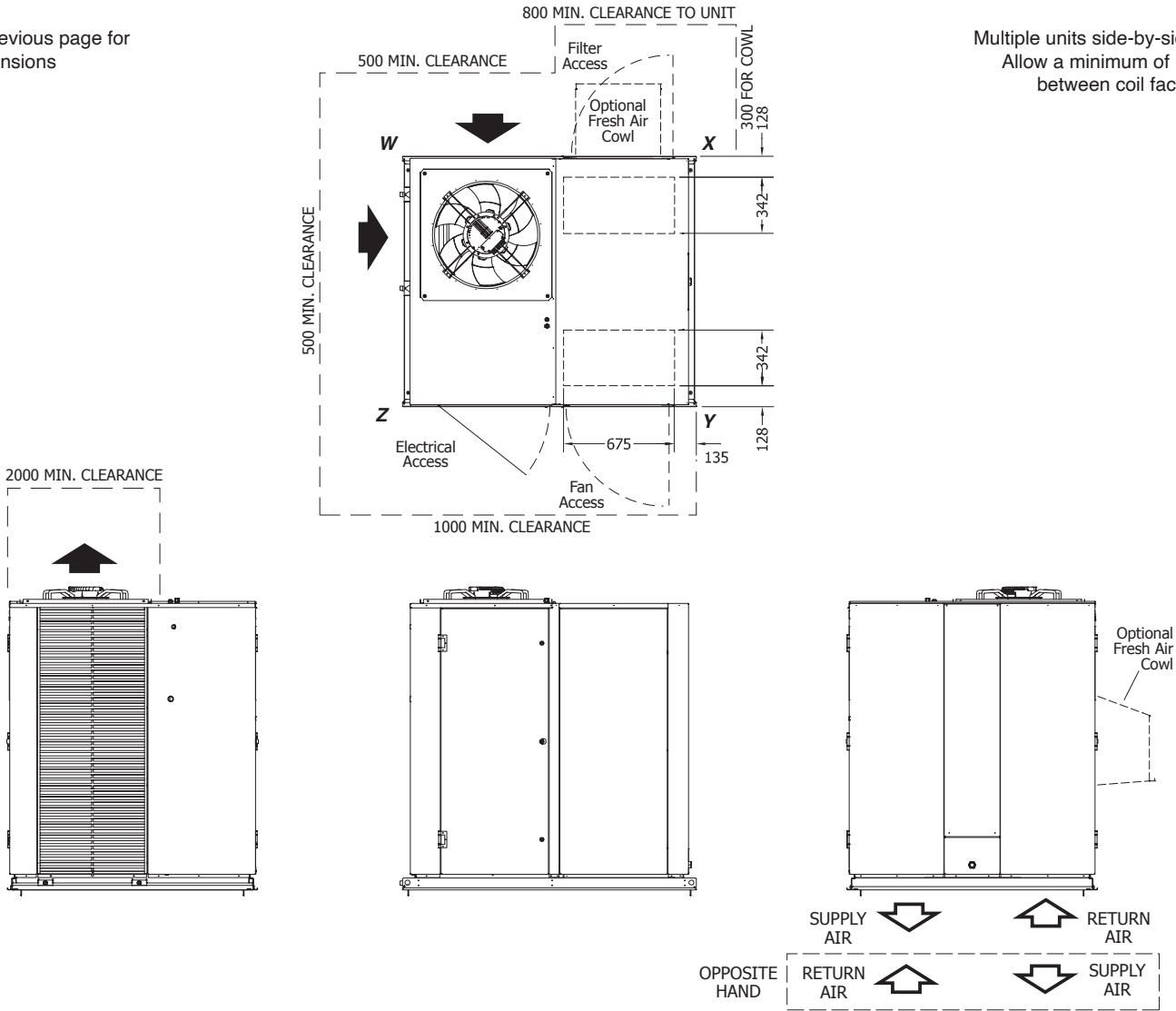

Materials and specifications are subject to change without notice due to the manufacturer's ongoing research and development programme.



Packaged Rooftop Air Conditioners R32

Dimensions (mm)

OPA 450RLTFPQ Horizontal Supply

		POINT LOADS (kg)			
		W	X	Y	Z
Std Hd	no F/A	134	170	134	205
	cw F/A	134	179	134	205
Op Hd	no F/A	148	173	133	189

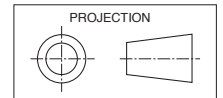

Not to scale

Refer page 26 for
Optional Economiser Cowl
dimensions

Multiple units side-by-side:
Allow a minimum of 1m
between coil faces.

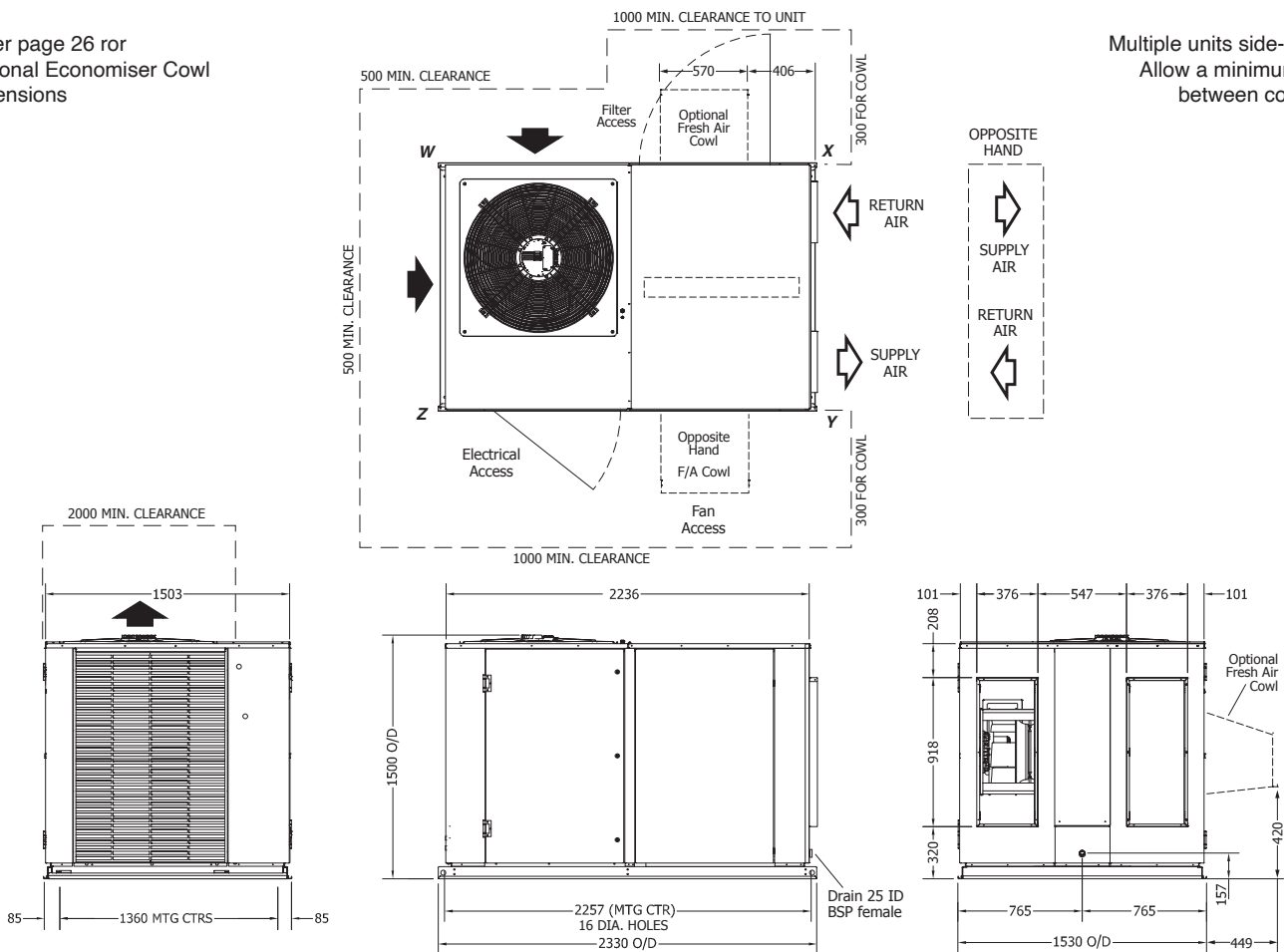

Materials and specifications are subject to change without notice due to the manufacturer's ongoing research and development programme.



Packaged Rooftop Air Conditioners R32

Dimensions (mm)

OPA 450RLTFPQ Downward Supply

		POINT LOADS (kg)			
		W	X	Y	Z
Std Hd	no F/A	134	170	134	205
	cw F/A	134	179	134	205
Op Hd	no F/A	148	173	133	189

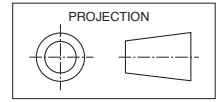

Not to scale

Refer previous page for full dimensions

Multiple units side-by-side:
Allow a minimum of 1m
between coil faces.

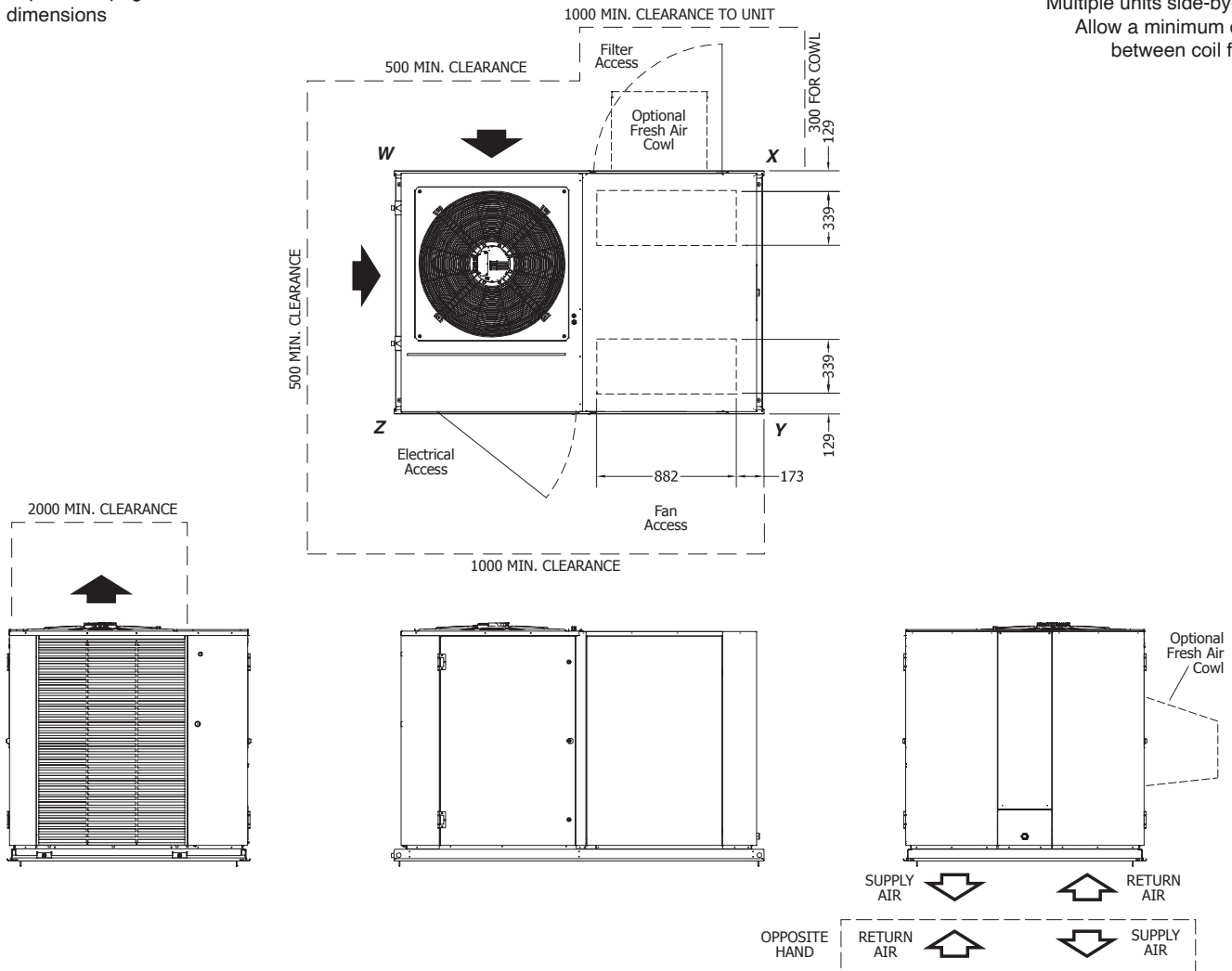



Packaged Rooftop Air Conditioners R32

Dimensions (mm)

OPA 560RLTFPQ Horizontal Supply

		POINT LOADS (kg)			
		W	X	Y	Z
Std Hd	no F/A	182	171	195	211
	cw F/A	196	199	207	217
Op Hd	no F/A	168	218	153	220

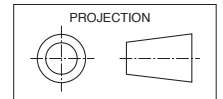

Not to scale

Refer page 26 for
Optional Economiser Cowl
dimensions

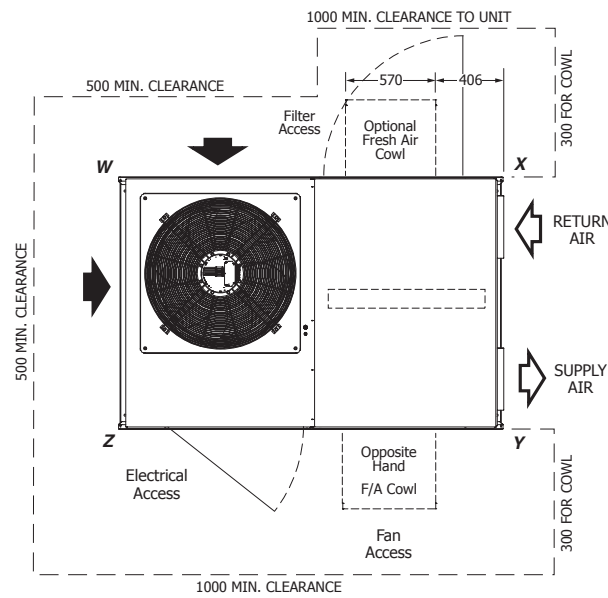

Multiple units side-by-side:
Allow a minimum of 1m
between coil faces.

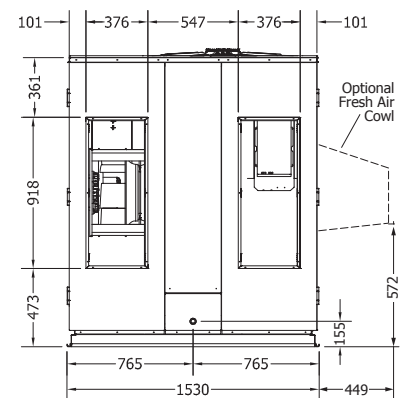
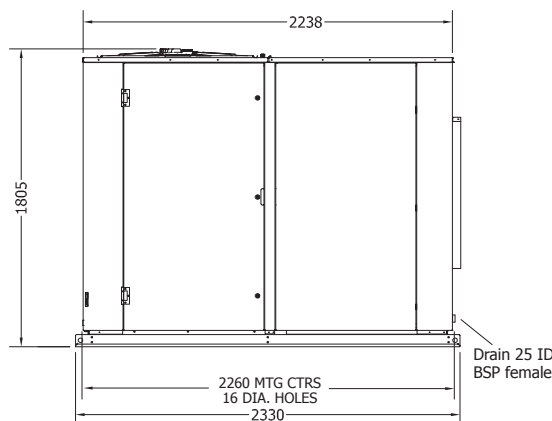
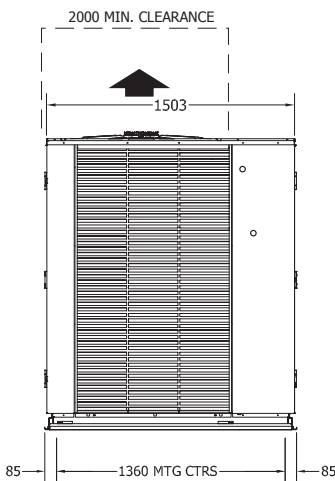



Packaged Rooftop Air Conditioners R32

Dimensions (mm)

OPA 560RLTFPQ Downward Supply

		POINT LOADS (kg)			
		W	X	Y	Z
Std Hd	no F/A	182	171	195	211
	cw F/A	196	199	207	217
Op Hd	no F/A	168	218	153	220

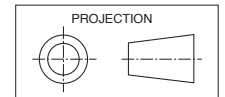

Not to scale

Refer previous page for full dimensions

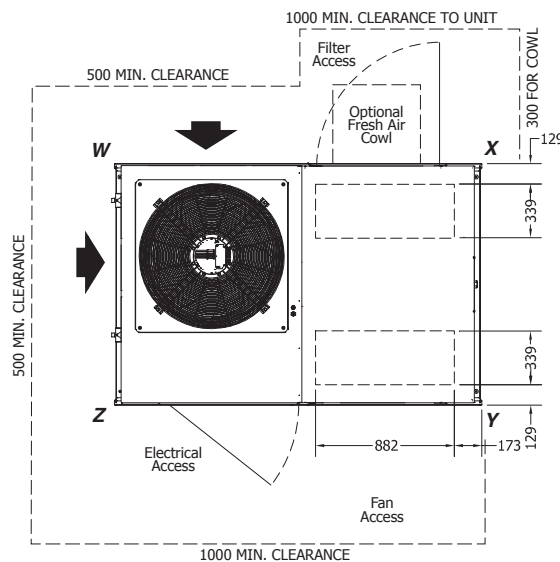

Multiple units side-by-side:
Allow a minimum of 1m
between coil faces.

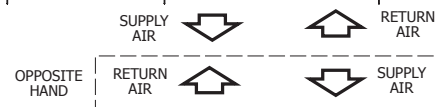
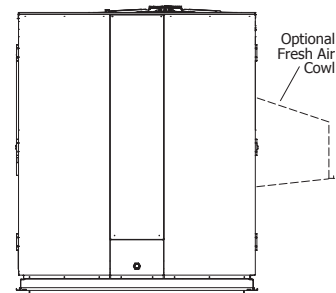
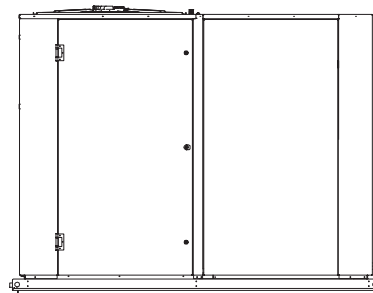
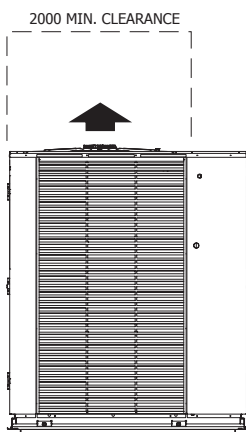



Packaged Rooftop Air Conditioners R32

Dimensions (mm)

Accessories

Note: Both Economiser and Fresh Air Cowls are mounted on a hinged access door.

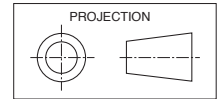

Not to scale

Economiser Cowl

Model	Dimension		
	A	B	C
OPA 250-Z	608	201	1000
OPA 350-Z	608	201	1000
OPA 450-Z	803	290	1200
OPA 560-Z	803	290	1200

Fresh Air Cowl

Model	A	B	C
	OPA 250-C	235	505
OPA 350-C	235	658	286
OPA 450-C	421	480	453
OPA 560-C	421	633	453

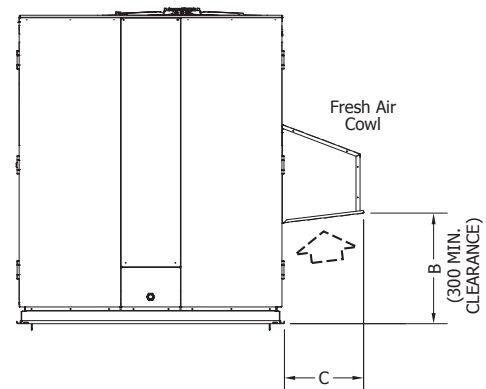
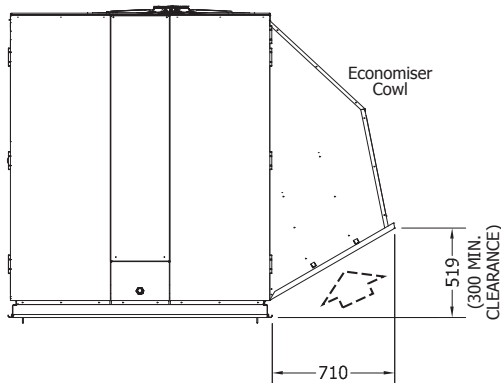
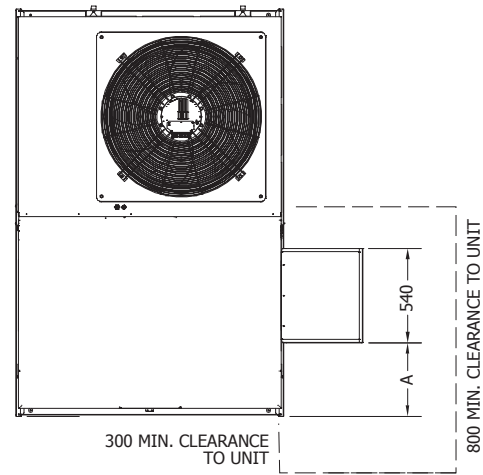
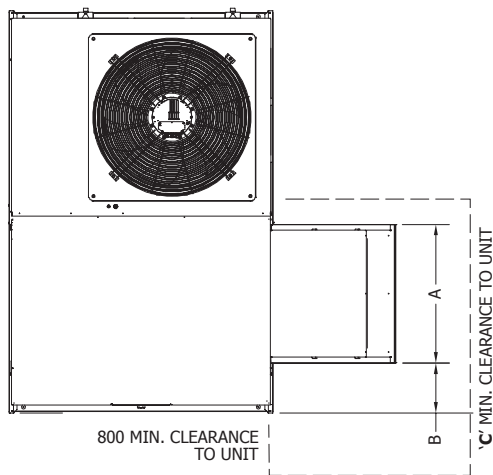



Packaged Rooftop Air Conditioners R32

Specifications

econex
nex gen R32 inverter

System				
Model	OPA 250RLTFPQ	OPA 350RLTFPQ	OPA 450RLTFPQ	OPA 560RLTFPQ
Cooling Capacity ¹ kW	25.4 (10.1~29.1)	35.9 (18~45.4)	44.9 (18.2~52.4)	55.6 (27.4~64.8)
Net Cooling Capacity (MEPS) ¹ kW	24.6	34.8	43.3	53.6
TCSPF ¹ (cold/mixed/hot)	6.43 / 5.41 / 4.73	4.71 / 5.60 / 4.85	5.20 / 4.56 / 4.34	5.22 / 4.60 / 4.21
EER / AEER (cooling)	3.20 / 3.18	3.15 / 3.14	2.99 / 2.98	2.99 / 2.98
Heating Capacity ² kW	26.9 (6.5~29.3)	37.0 (13.9~47)	44.4 (16.5~54.5)	57.0 (24.0~63.0)
HSPF ² (cold/mixed/hot)	2.21 / 2.60 / 3.30	2.85 / 3.00 / 3.07	2.72 / 2.82 / 2.86	2.66 / 2.83 / 2.94
COP / ACOP (heating)	3.33 / 3.31	3.21 / 3.19	3.14 / 3.13	2.98 / 2.97
Nominal Air Flow ³ l/s	1250 (625~1950)	1800 (1100~2450)	2200 (1100~2900)	2600 (1300~3610)
Unit Controller	UC8			
Power Source ⁴	3 phase 400 V a.c. 50 Hz + N + E			
Refrigerant	R32 (Class A2L)			
Compressor type	inverter scroll			
Indoor air fan type	backward curved EC plug			
Outdoor air fan type	EC axial			
Indoor Fan Max. Current A/ph.	6	5.5	5.5	6.4
Running Amps (Total) A/ph.	12.5 / 11.5 / 13	17.5 / 15.5 / 19.5	24 / 22 / 24	28 / 26 / 29
Max. Running Amps (Total) A/ph.	24	35	40	44
IP Rating	IP44 / IPX4 ⁵			
Finish	grey polyester powder coat			
Operating Range (outdoor ambient)				
Cooling	-10°C to 52°C			
Heating	-15°C to 25°C			
Weight (net/shipping) kg				
Unit	511 / 567	596 / 652	643 / 708	759 / 823
Unit c/w Fresh Air	519 / 575	604 / 660	652 / 717	817 / 881
Unit c/w Economiser	556 / 612	649 / 674	697 / 762	831 / 895

Notes:

- ¹ Nominal Cooling Capacity (gross) at AS/NZS 3823 conditions:
- Indoor Entering Air Temperature 27°C D.B., 19°C W.B.;
 - Outdoor Entering Air Temperature 35°C D.B.
- ² Heating Capacity at AS/NZS 3823 conditions:
- Indoor Entering Air Temperature 20°C D.B.;
 - Outdoor Entering Air Temperature 7°C D.B., 6°C W.B.

- ³ Supply air flow at Nominal Cooling Capacity conditions stated above. Air flows less than Nominal will reduce cooling capacity.
- ⁴ Voltage range: 376-440 V
- ⁵ Outdoor fan clearance <100mm (ref. IEC 60529)

Materials and specifications are subject to change without notice due to the manufacturer's ongoing research and development programme.



Packaged Rooftop Air Conditioners R32

Notes



Packaged Rooftop Air Conditioners R32

Notes

www.temperzone.biz

Auckland

Head Office

38 Tidal Rd, Mangere, Auckland
Private Bag 93303, Otahuhu
New Zealand

Email: sales@temperzone.co.nz

Phone: (09) 279 5250

Fax: (09) 275 5637

Sydney

Head Office

14 Carnegie Place, Blacktown
NSW 2148
PO Box 8064, Seven Hills West
NSW 2147, Australia

Email: sales@temperzone.com.au

Phone: (02) 8822 5700

Fax: (02) 8822 5711

Newcastle

Phone: (02) 4692 1155

Fax: (02) 4961 5101

Launceston

Phone: (03) 6331 4209

Fax: (03) 6333 0224

Wellington

Phone: (04) 569 3262

Fax: (04) 566 6249

Adelaide

Phone: (08) 8115 - 2111

Fax: (08) 8115 2118

Singapore

Phone: +65 6733 4292

Fax: +65 6235 7180

Christchurch

Phone: (03) 379 3216

Fax: (03) 379 5956

Melbourne

Phone: (03) 8769 7600

Fax: (03) 8769 7601

Brisbane

Phone: (07) 3308 8333

Fax: (07) 3308 8330

Perth

Phone: (08) 9314 3844

Fax: (08) 9314 3855

