

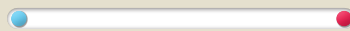

Water Cooled Units Technical Data

HWP 141, 171, 191, 225, 290, 291, 370, 445



Cooling Capacity
13.6kW - 44.5kW

Heating Capacity
14.7kW - 42.2kW

Water Cooled Air Conditioners



Contents

HWP 141–445	
General	3
Applications	4
Introduction	4
Features	5
Refrigerant	5
Efficient	5
Performance	5
Durable	5
Quiet	5
Unit Protection	5
Insulation	5
Inverter Model	5
Control Options	5
Peace of Mind	5
Electric Heating	5
Accessories	6
Air Filter	
Flexible Hoses	6
Spring Mounting Kit	6
Condensate Lift-Pump	6
Optional Equipment	6
Application Considerations	6
Water Connection	7
Safety Features	7
Electrical	7
TZT-100 Room Controller	7
Safety Connection	7
Nomenclature	8
Technical Support	8
PERFORMANCE DATA	
Cooling Capacity	9
Heating Capacity	10
Air Handling Performance	11
Sound Levels	12
Supply Air + Insulated Duct	12
Supply Air Outlet	13
Case Breakout + Return Air	14
Sound Pressure Levels (SPL) Within A Room	15
Recommendations for Noise Isolation	15
DIMENSIONS	16
SPECIFICATIONS	20

Materials and specifications are subject to change without notice due to the manufacturer's ongoing research and development programme.

Water Cooled Air Conditioners

HWP 141–445 series



The HWP units provide a choice of cooling or reverse cycle (heat pump) packaged system air conditioners designed and developed to comply with and exceed AS / NZS 3823.

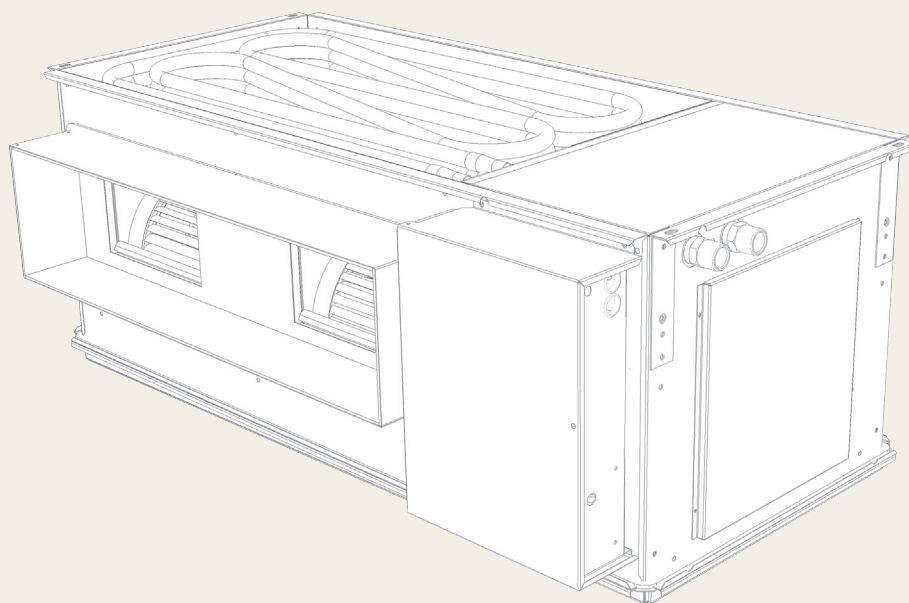

Water Cooled Air Conditioners

HWP 141–445 series



Applications

The HWP-K units are ideal for multi-unit installations such as high-rise office, apartments or hotel buildings, where the flexibility of individual zone control is required.

INTRODUCTION

The temperzone HWP-K series is a range of ducted water sourced packaged air conditioners designed to provide year round comfort to room occupiers.

Compact & reliable, these units can be installed above the ceilings, corridors or dedicated plant area, saving valuable floor space and providing conditioned air direct to the required locations.

HWP-K series are designed to be used with simple duct layouts. To take maximum advantage of this feature, units should be located as close to the space to be air conditioned as acoustic criteria allows. Multiple smaller units, utilizing minimal duct lengths can prove to be more economical than a large central ducted unit.

Designed also to suit different climates, the HWP-K series are available in 3 versions

1. Reverse cycle (R)
ie Heat Pump / Cooling & Heating
2. Cooling Only (C)
3. Cooling with Electric Heat (CE)

The standard unit is right handed, i.e. when facing the discharge side of the unit, the water connections are on the right hand side of the unit. Opposite Hand versions are also available.

In office buildings, an HWP unit system can provide the ideal off-peak system for occupied areas when the main system is not running, e.g. night time, weekends, holidays.

HWP unit systems can be applied to provide owner occupiers with individual control and billing, thus avoiding large central plant room areas, e.g. in apartment buildings.

Installing multiple reverse cycle units enables simultaneous cooling and heating in different parts of the buildings.

HWP systems are typically part of an overall water cooled (Hydronic) system that incorporates a form of heat rejection, usually a cooling tower, heat exchanger or radiator (dry) cooler.

Water Cooled Air Conditioners

HWP 141–445 series



FEATURES

Refrigerant

Each unit is factory charged with refrigerant R410A, which has a zero ozone depletion potential.

Efficient

These air conditioners provide one of the most efficient forms of cooling and / or heating you can invest in; each unit incorporates a high efficiency scroll compressor. Heat exchange coils use inner grooved (rifled) tube for a better heat transfer.

Performance

Fan speed can be stepped using High / Medium / Low to match the supply air requirements.

Durable

Temperzone units have a tough galvanised steel construction. The evaporator coil is a die formed plate type epoxy coated aluminium fins epoxy coated, mechanically bonded to high efficiency rifled copper tube. Each HWP 141 – 445 unit can (excluding flexible hoses) withstand a maximum water pressure of 2760kPa (400 psi). Condensate drain trays are insulated and powder coated for complete moisture protection. The drain tray is easily removed for inspection and cleaning.

Quiet

HWP-K series are well insulated to minimize and attenuate noise. Spring mounting kits are supplied with the units to minimise vibration transfer.

Unit Protection

Units are fitted with a high pressure lockout protection. These protect the unit in the event of a condenser water flow failure in cooling mode. Sensors protect against low evaporator coil temperature and loss of refrigerant. Units include an anti-rapid cycle timer for compressor on / off protection.

HWP reverse cycle units also have a low refrigerant temp safety to protect against icing up of the water within the tube in tube heat exchanger in heating mode, and a pump flow verification to protect individual units from a loss of water flow.

Convenient lockout contactor re setting is achieved by turning the power supply to the unit off, then on again, avoiding the need to access each unit if the cause of a fault is the failure of the condenser water supply.

Each compressor has internal overload protection.

Insulation

Closed cell foam insulation has been used in the indoors cabinet to ensure no particles are introduced into the airstream. Insulation is foil faced and meets fire test standards AS 1530.3 (1999) and BS 476 parts 6 & 7.

Inverter Model

HWP 291 has an inverter compressor that provides variable capacity (20-120%) performance and close temperature control. It is very efficient at part load. Extra boost capacity is available for fast response when well away from set point at start-up.

HWP 291 may be suitable for applications using full or high proportions of fresh air (nb pre-heating on heating cycle may be required); also for VAV, close control and supply air temperature control. Refer to temperzone Engineering.

Control Options

HWP 141–225 unit's with UC7 Controller can be connected to Temperzone's TZT-100 or other compatible room temperature controllers supplied by others. It is BMS compatible via Modbus/RS485 port with multi-unit control possible – either via digital and analogue signals or via Modbus. The UC7 can activate the water circulating pump (only when required) and/or a local water on/off valve, thus saving pump running costs. It can also control the position of a motorised water flow control valve (using 0–10V signal), so that head pressure control can be achieved and lower water temperatures can be used on cooling mode. NB UC6 Controller used on HWP 291 has same feature.

Peace of Mind

temperzone operates a quality management system that conforms to AS/NZS ISO 9001 :2008. temperzones products have been selected against worldwide competition, for use in some of the most exclusive projects – chosen because of their proven efficiency, durability, performance, reliability and value.

Electric Heating

(HWP-CE model)

Electric element/s have spiral wound stainless steel fins to give increased area and low surface temperature. They are totally enclosed within the unit and are supplied with an auto (90°C) and manual (120°) high temp. safety thermostats required to meet AS/ NZS 60335.2.2006.

Water Cooled Air Conditioners

HWP 141–445 series



ACCESSORIES (SUPPLIED)

Flexible Hoses

HWP 141 – 225 are supplied with two 800mm long flexible hoses for water connections. These hoses have female pipe threaded nut fittings at both ends, and have a maximum water pressure of 1720kPa (250psi).

The flexible hoses are optional for the HWP 290 – 445.

Spring Mounting Kit

The HWP series Spring Mounting Kit supplied with each unit has been designed to minimise the transfer of vibration from the unit to the building structure. It is recommended to use for all HWP installations

Air Filter

Air filters are not supplied, however HWP 141–225 have an optional filter box available complete with a washable synthetic fibre EU2/G2 rated filter. HWP 290–445 are supplied with return air spigot as standard; filters optional.

For ducted return air applications, filters should ideally be located in the ceiling return air grille/s and removed from the HWP unit's return air spigot, thereby reducing resistance and improving access for cleaning.

OPTIONAL EQUIPMENT

1. temperzone TZX-100 Controller
– connection cables supplied separately.
2. Filter box c/w EU2/G2 washable synthetic fibre filter for HWP 141–225.
3. Filters for HWP 290/370/445 - EU2/G2 washable synthetic fibre.
4. Filters for HWP 291 - EU4/G4 disposable.
5. Condensate -Lift Pump – max. lift 800mm.
6. Flexible Hoses for HWP 290–445.
7. Status/fault relay board (201-000-105) for HWP 141–225.

APPLICATION CONSIDERATIONS

Acoustics

Shorter duct applications will require greater attention to acoustic criteria (refer page 15).

Mounting

It is recommended that HWP units be mounted using the spring mounting system supplied. This system minimises transfer of vibration into the building structure.

Positioning

When determining the installation location consideration should be given to each unit to facilitate future servicing and maintenance, e.g. room for removal of filter and access to electrics.

Condensate Drain

The condensate drain should have a slope of at least 1 in 50 and must not be piped to a level above the unit drain tray.

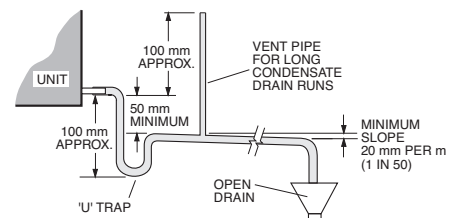

An optional condensate lift-pump is available to remove condensate from the unit in tight installations where a well sloped drain line is not practical.

Water Cooled Air Conditioners

HWP 141–445 series



WATER CONNECTION

General

The HWP unit's IN and OUT water connections are male pipe threaded. The unit can be piped directly or by using two temperzone flexible high pressure water hoses (supplied with HWP 141–225) which have female pipe threaded connections at each end.

Poor quality water supply must be pre-filtered and it is essential that adequate water treatment is maintained, particularly where open cooling towers are used.

Note: It is recommended that the water supply system be fitted with a water flow switch and water flow verification circuit. These items prevent the HWP units from going into fail safe lockout status due to a loss of water flow. Failure to install the above items could require the resetting of all HWP units in the system – by breaking the power supply to each unit or by Modbus command.

HWP*R units require a minimum water supply temperature of 17°C.

Circuit Balancing Valve

It is recommended that a circuit balancing valve be fitted to maintain water flow at a constant rate. The water flow rates in litres per second (l/s), at nominal water temperature, are stated in the Specifications Table (page 20). The water circuit needs to be balanced to suit the design ΔT of the central water system.

The HWP unit controller will protect the refrigeration system of the unit under extreme conditions. On heating cycle it protects to ensure the evaporating temperature does not drop below freezing point for an extended period. The extreme lowest leaving water temperature needs to be such that the unit does not cut-out on protection and will be above approx. 4°C. This can be achieved by a combination of the entering Water Temperature (EWT) and the reduced flow rate.

Water Circulating Pump & Flow Verification Option

In order to promote efficiency and avoid running the water circulation pump unnecessarily, units with UC7 Controller (ie HWP 141–225) can be used to control the activation of the pump prior to running the compressor. After activation of the circulating pump contactor (not part of the HWP unit), the UC7 waits for the pump flow verification relay contact (PFVR) to close before energising the compressor contactor (CMC) and therefore starting the compressor (refer wiring diagram). The UC7 also de-activates the pump when the compressor stops. HWP 290/370/445 c/w SAT-2 Controller can activate a water circulating pump only when required.

Water Control Options

System designers have one of two options:

1. Water Regulating Valve Control Option

HWP 141–225: A 0-10V signal is available on output V1 for the control of a water flow control valve (optional; not supplied by temperzone); refer wiring diagram. When used, the valve is closed (0V signal) when the compressor is off. When the unit is cooling the signal will control the valve to obtain an optimum condensing temperature. When the unit is heating (reverse cycle units) the valve is directed fully open (10V signal).

OR

2. Water Shut-Off Valve Option

This will ensure the water is not flowing through the unit when it is not operational for a long period of time, thereby reducing the overall central pump power usage. The water shut-off relay on the HWP can be used to activate a water shut-off valve (supplied and fitted by others).

SAFETY FEATURES

1. HP and loss of refrigerant protection.
2. Anti-rapid cycle timer and internal overload for compressor protection.
3. Circuit breaker control circuits.
4. Electronic pressure control prevents icing up of the tube-in-tube heat exchanger during heating cycle.
5. Frost protection on cooling cycle.
6. Sensor fault indication.
7. Compressor minimum run time to ensure oil return.

ELECTRICAL

The electrical supply required (including voltage fluctuation limits) is: 3 phase 342–436 V a.c. 50 Hz with neutral and earth.

All units are compliant to the latest MEPS standards for power factor.

Water Cooled Air Conditioners

HWP 141-445 series



TZT-100 ROOM CONTROLLER (OPTIONAL)

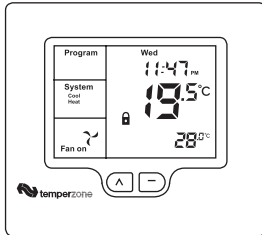

Features:

- Cool / Cool Dry / Heat / Auto Dry / Auto / Fan Only modes.
- Auto / High / Medium / Low fan speed selection. (customisable).
- Temperature setting range from 0°C – 38°C in 0.5° increments..
- Room temperature display.
- Real time clock.
- **7 day timer** – up to four events (four start and/or stops per day)
- On demand countdown run timer for after hours use.
- Auto-Restart after power failure.
- Continuous or Intermittent selection of fan run-on in dead zone.
- Backlit screen for ease of reading; changes colour for each mode.
- Soft touch tab keys
- Battery backup (Lithium).
- Low voltage control cable.
- Remote return air sensor option.
- PIN protected menus (installer PIN)
- Key pad lock
- Central control - integrated Modbus option
- Occupancy sensor inputs
- Outside air temperature display
- Filter clean indicator
- Fault indicator

Note: TZT-100 is not suitable for HWP 290, 370 & 445; ask about temperzone's alternative SAT-2 Controller.

NOMENCLATURE

Example



H - Hideaway
W - Water Sourced
P - Packaged

141
Divide by 10
to get approx.
nominal
Capacity in
kilowatts

CE - Cooling only with electric heat
R - Reverse cycle
K - Refrigerant R410A
T - Three phase power supply

TECHNICAL SUPPORT

For more information on the manufacturer or product support information, visit the website www.temperzone.biz

Water Cooled Air Conditioners

Performance Data



COOLING CAPACITY (KW)

- T = Total Capacity (kW).
- S = Sensible Capacity (kW)
- FL = Water Flow (l/s)
- HR = Heat Rejection (kW)
- E.A.T. = Entering Air Temperature
- = Nominal Capacity (kW)

Note: Capacities are **gross** and do not include allowance for fan motor heat loss. For fan motor heat loss refer to Air Handling Performance. Water flow and cooling capacity based on 5 °C water temperature difference.

Model	Air Flow Rate (l/s)	Coil E.A.T		LEAVING WATER TEMPERATURE (L.W.T.) °C																							
		W.B °C	D.B °C	25				30				35				40				45				50			
				T	S	FL	HR	T	S	FL	HR	T	S	FL	HR	T	S	FL	HR	T	S	FL	HR	T	S	FL	HR
HWP141	760	17	23	14.1	10.8	0.78	16.3	13.4	10.1	0.78	15.9	12.8	9.6	0.78	15.6	12.2	9.4	0.78	15.1	12.0	9.0	0.78	15.1	11.9	8.2	0.78	15.0
		19	27	15.0	10.9	0.78	17.4	14.8	10.7	0.78	17.4	13.6	10.6	0.78	16.3	13.3	10.1	0.78	16.3	12.2	10.0	0.78	15.2	12.0	9.8	0.78	15.2
		21	31	16.0	12.6	0.78	18.0	15.9	12.5	0.78	18.4	15.8	12.5	0.78	18.7	14.4	12.3	0.78	17.4	13.8	12.1	0.78	16.9	13.0	12.1	0.78	16.2
HWP171	1015	17	23	16.4	12.7	0.9	19.1	15.7	11.8	0.9	18.6	15.0	11.3	0.9	18.2	14.3	10.9	0.9	17.7	14.0	10.5	0.9	17.6	13.9	9.5	0.9	17.5
		19	27	17.6	12.7	0.9	20.3	17.4	12.5	0.9	20.4	15.9	12.4	0.9	19.1	15.5	11.8	0.9	19.0	14.3	11.7	0.9	17.8	14.0	11.4	0.9	17.8
		21	31	18.8	14.8	0.92	21.1	18.6	14.7	0.9	21.5	18.4	14.6	0.9	21.8	16.8	14.4	0.9	20.4	16.1	14.2	0.9	19.8	15.2	14.1	0.9	19.0
HWP191	1060	17	23	19.6	15.1	1.17	22.8	18.7	14.1	1.17	22.2	17.8	13.4	1.17	21.8	17.0	13.0	1.17	21.1	16.7	12.5	1.17	21.0	16.5	11.4	1.17	21.0
		19	27	21.0	15.2	1.17	24.2	20.7	14.9	1.17	24.3	18.9	14.8	1.17	22.8	18.5	14.1	1.17	22.7	17.0	13.9	1.17	21.2	16.7	13.6	1.17	21.2
		21	31	22.3	17.65	1.17	25.2	21.1	17.5	1.17	25.7	22.0	17.4	1.17	26.1	20.0	17.2	1.17	24.3	19.2	16.9	1.17	23.6	18.1	16.8	1.17	22.6
HWP225	1180	17	23	23.8	18.4	1.2	27.8	22.7	17.1	1.2	27.1	21.7	16.3	1.2	26.5	20.7	15.9	1.2	25.8	20.4	15.2	1.2	25.7	20.1	13.8	1.2	25.6
		19	27	25.5	18.5	1.2	29.6	25.2	18.2	1.2	29.7	23.1	18.0	1.2	27.8	22.5	17.1	1.2	27.7	20.7	16.9	1.2	25.9	20.4	16.6	1.2	25.9
		21	31	27.2	21.4	1.2	30.8	27.0	21.3	1.2	31.3	26.8	21.2	1.2	31.8	24.4	21.0	1.2	29.7	23.4	20.6	1.2	28.8	22.1	20.5	1.2	27.6
HWP290	1500	17	23	29.7	22.9	1.5	34.3	28.3	21.3	1.5	33.3	27.0	20.3	1.5	32.7	25.8	19.8	1.5	31.7	25.4	18.9	1.5	31.6	25.1	17.2	1.5	31.5
		19	27	31.8	23.0	1.5	36.4	31.4	22.6	1.5	36.5	28.7	22.5	1.5	34.2	28.0	21.3	1.5	34.1	25.8	21.0	1.5	31.8	25.4	20.6	1.5	31.8
		21	31	33.9	26.6	1.5	37.8	33.6	26.5	1.5	38.5	33.3	26.4	1.5	39.2	30.4	26.1	1.5	36.5	29.1	25.7	1.5	35.4	27.5	25.5	1.5	34.0
HWP291	1400	17	23	28.6	22.0	1.58	33.0	27.3	20.5	1.58	32.1	26.1	19.6	1.58	31.4	24.8	19.1	1.58	30.5	24.4	18.2	1.58	30.4	24.2	16.6	1.58	30.3
		19	27	30.6	22.2	1.58	35.0	30.2	21.8	1.58	35.2	27.7	21.6	1.58	33.0	27.0	20.5	1.58	32.9	24.8	20.3	1.58	30.7	24.4	19.9	1.58	30.7
		21	31	32.6	25.7	1.58	36.4	32.4	25.5	1.58	37.1	32.1	25.4	1.58	37.7	29.3	25.1	1.58	35.2	28.1	24.7	1.58	34.1	26.5	24.6	1.58	32.7
HWP370	1900	17	23	37.8	29.2	2.0	42.9	36.1	27.2	2.0	41.7	34.5	25.9	2.0	40.8	32.9	25.2	2.0	39.7	32.3	24.1	2.0	39.5	32.0	22.0	2.0	39.3
		19	27	40.5	29.3	2.0	45.5	40.0	28.8	2.0	45.7	36.6	28.6	2.0	42.8	35.7	27.2	2.0	42.7	32.9	26.8	2.0	39.8	32.3	26.3	2.0	39.8
		21	31	43.2	34.0	2.0	47.3	42.8	33.8	2.0	48.2	42.5	33.6	2.0	49.0	38.7	33.2	2.0	45.7	37.1	32.7	2.0	44.3	35.0	32.5	2.0	42.5
HWP445	2300	17	23	46.0	35.5	2.25	53.3	43.9	33.0	2.25	51.8	41.9	31.5	2.25	50.8	40.0	30.6	2.25	49.3	39.3	29.3	2.25	49.1	38.9	26.7	2.25	48.9
		19	27	49.3	35.7	2.25	56.6	48.6	35.0	2.25	56.8	44.5	34.8	2.25	53.3	43.4	33.0	2.25	53.1	40.0	32.6	2.25	49.5	39.3	32.0	2.25	49.5
		21	31	52.5	41.3	2.25	58.9	52.1	41.1	2.25	59.9	51.6	40.9	2.25	60.9	47.1	40.4	2.25	56.8	45.1	39.8	2.25	55.1	42.6	39.6	2.25	52.9

Water Cooled Air Conditioners

Performance Data



HEATING CAPACITY (KW) HW*R REVERSE CYCLE VERSION

HC = Heating Capacity (kW)

HAb = Heat Absorbed (kW)

EWT = Entering Water Temperature (°C) (Minimum required 17°C)

INPT = Compressor Input (kW)

E.A.T. = Entering Air Temperature (°C)

○ = Nominal Capacity (kW)

Model	Water Flow Rate l/s	Coil E.A.T. D.B. °C	LEAVING WATER TEMPERATURE (L.W.T.) °C											
			12.5				15.5				18.5			
			HC	HAb	EWT	INPT	HC	HAb	EWT	INPT	HC	HAb	EWT	INPT
HWP141R	0.74	18	13.8	10.3	16.8	3.0	14.8	11.2	20.1	3.2	15.9	12.1	23.5	3.3
		21	13.7	10.1	16.8	3.2	14.7	11.3	20.1	3.4	15.8	11.8	23.4	3.5
		25	13.7	9.7	16.8	3.5	14.7	10.6	20.1	3.7	15.7	11.5	23.4	3.8
HWP171R	1.0	18	15.5	11.3	16.1	3.7	16.6	12.2	19.3	3.8	17.8	13.2	22.6	4.0
		21	15.4	10.9	16.0	3.9	16.5	12.4	19.3	4.1	17.7	12.9	22.6	4.3
		25	15.3	10.5	16.0	4.2	16.5	11.5	19.3	4.4	17.6	12.5	22.6	4.6
HWP191R	1.15	18	17.3	12.6	16.0	4.1	18.5	13.6	19.2	4.2	19.8	14.8	22.5	4.4
		21	17.1	12.2	15.9	4.3	18.4	13.9	19.2	4.5	19.8	14.4	22.5	4.7
		25	17.1	11.8	15.9	4.7	18.4	12.9	19.2	4.9	19.7	14.0	22.5	5.1
HWP225R	1.2	18	21.0	15.2	16.4	5.0	22.4	16.4	16.7	5.2	24.1	17.9	23.0	5.4
		21	20.8	14.8	16.4	5.2	22.3	16.0	19.7	5.5	24.0	17.4	23.0	5.8
		25	20.7	14.2	16.4	5.7	22.3	15.5	19.7	5.9	23.9	16.9	23.0	6.2
HWP290R	1.5	18	26.9	20.0	16.6	5.8	28.8	21.6	19.9	6.0	30.9	23.4	23.2	6.3
		21	26.7	19.4	16.6	6.1	28.6	21.0	19.9	6.4	30.8	22.8	23.2	6.7
		25	26.6	18.8	16.5	6.6	28.6	20.5	19.9	6.9	30.6	22.2	23.2	7.2
HWP291R	1.58	18	26.8	19.1	16.4	6.3	28.6	20.7	19.6	6.6	30.7	22.5	22.9	6.8
		21	26.5	18.6	16.3	6.6	28.5	21.5	19.6	7.0	30.6	21.9	22.9	7.3
		25	26.5	17.9	16.3	7.2	28.5	19.6	19.6	7.6	30.4	21.2	22.9	7.9
HWP370R	2.0	18	32.8	24.5	16.2	6.5	35.1	26.4	19.5	6.8	37.6	28.7	22.8	7.1
		21	32.5	23.8	16.2	6.9	34.9	25.8	19.4	7.2	37.5	28.1	22.7	7.6
		25	32.4	23.1	16.2	7.5	34.9	25.2	19.4	7.8	37.3	27.3	22.7	8.1
HWP445R	2.25	18	39.8	29.0	16.5	8.3	42.5	31.4	19.8	8.7	45.5	34.1	23.1	9.0
		21	39.4	28.2	16.4	8.8	42.2	30.6	19.7	9.2	45.4	33.3	23.0	9.7
		25	39.3	27.3	16.4	9.6	42.2	29.8	19.7	10.0	45.2	32.4	23.0	10.4

Water Cooled Air Conditioners

Performance Data



AIR HANDLING

Airflows are for a dry coil. Reduce air flow by 10% in high moisture removal conditions. In a free blow application, beware of exceeding fan motor's full load amp limit. Refer back page for filter losses. **Air flows given are for HWP units without filter installed.**

HWP 141

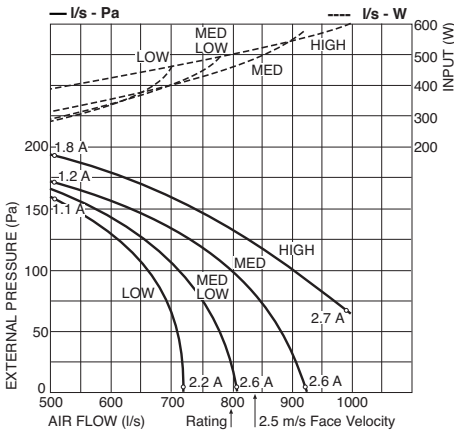

HWP 171

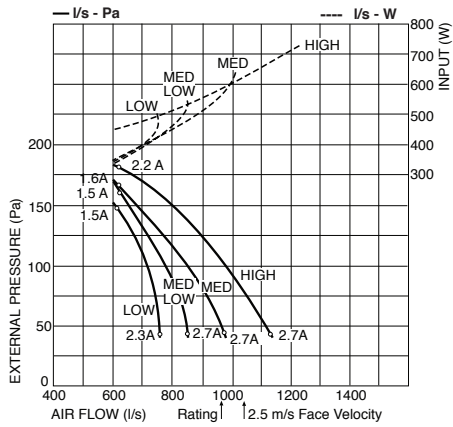

HWP 191

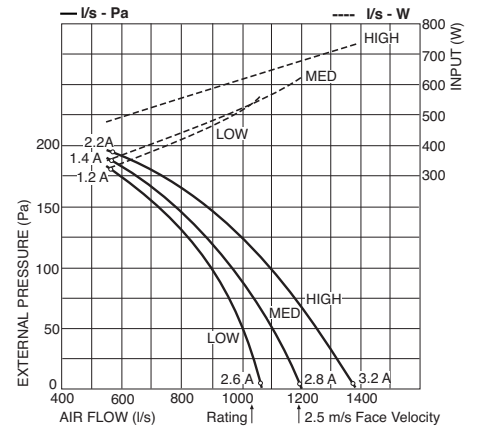

HWP 225

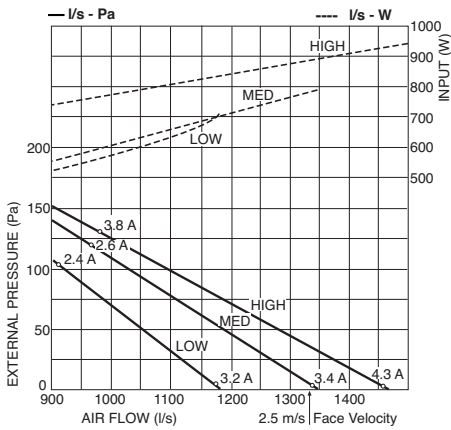

HWP 290

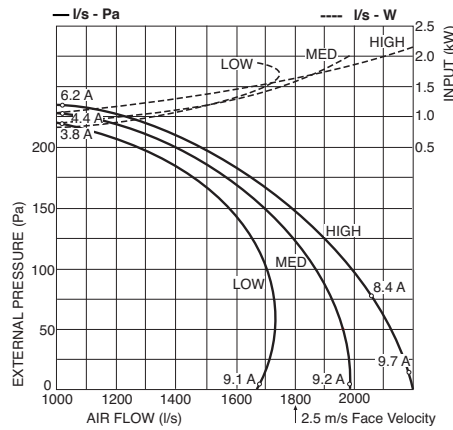

HWP 291

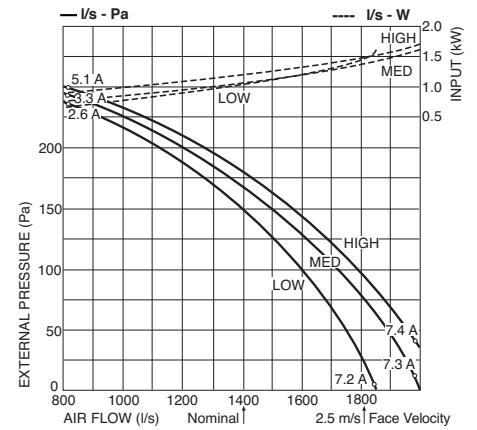

HWP 370

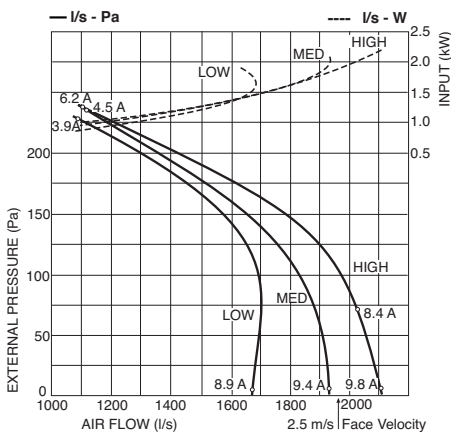

HWP 445

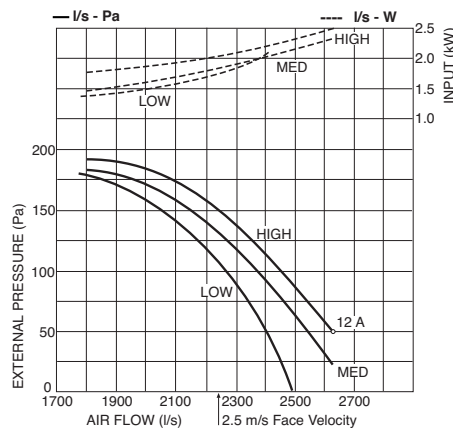

Filter (clean) - HWP 141 - 225, 370, 445

Coil Face Velocity (m/s)	1.5	2.0	2.5
Pressure Loss (Pa)	15	25	40

Filter (clean) - HWP 290

Coil Face Velocity (m/s)	1.5	2.0	2.5
Pressure Loss (Pa)	5	9	13

Filter (clean) - HWP 291

Coil Face Velocity (m/s)	1.5	2.0	2.5
Pressure Loss (Pa)	23	39	62

Water Cooled Air Conditioners

Performance Data



SOUND LEVELS

Note: SPL measured to JIS 8616 (1m from source in an anechoic chamber)

SUPPLY AIR + INSULATED DUCT

Model	FAN SPEED	Air Flow (l/s)	SOUND PRESSURE LEVELS (SPL) dB(A)	SOUND POWER LEVELS (SWL) dB						
				SWL dB(A)	OCTAVE BAND FREQ. Hz					
					125	250	500	1k	2k	4k
HWP 141	LOW	650	47	56	63	56	56	49	42	38
	MED/LOW	700	49	58	64	59	58	52	43	39
	MED	780	51	60	67	61	59	54	46	41
	HIGH	820	54	63	69	66	62	58	49	45
HWP 171	LOW	750	49	57	60	57	57	51	43	36
	MED/LOW	880	51	58	61	59	58	52	45	37
	MED	950	54	62	65	63	61	56	48	42
	HIGH	1000	58	65	69	66	64	60	52	47
HWP 191	LOW	1000	48	58	62	57	57	52	45	40
	MED	1050	50	60	63	59	60	54	46	41
	HIGH	1200	54	63	65	63	63	58	49	45
HWP 225	LOW	1000	52	62	65	61	62	56	48	39
	MED	1050	54	64	70	63	64	59	51	42
	HIGH	1200	58	68	72	66	66	65	55	46
HWP 290	LOW	1470	62	71	68	66	69	66	63	61
	MED	1520	63	72	69	67	69	66	65	63
	HIGH	1550	64	73	71	68	70	68	66	64
HWP 291	LOW	1470	62	71	68	66	69	66	63	61
	MED	1520	63	72	69	67	69	66	65	63
	HIGH	1550	64	73	71	68	70	68	66	64
HWP 370	LOW	1900	61	72	72	67	70	66	65	63
	MED	1900	62	73	74	68	70	68	66	64
	HIGH	1900	63	74	76	69	70	68	67	65
HWP 445	LOW	2300	63	73	71	68	70	68	66	64
	MED	2300	64	74	71	69	71	68	67	65
	HIGH	2300	64	74	72	70	71	69	67	65

Water Cooled Air Conditioners

Performance Data



SOUND LEVELS

Note: SPL measured to JIS 8616 (1m from source in an anechoic chamber)

SUPPLY AIR OUTLET

Model	FAN SPEED	Air Flow (l/s)	SOUND PRESSURE LEVELS (SPL) dB(A)	SOUND POWER LEVELS (SWL) dB						
				SWL dB(A)	OCTAVE BAND FREQ. Hz					
					125	250	500	1k	2k	4k
HWP 141	LOW	650	56	65	63	59	62	60	57	53
	MED/LOW	700	57	66	65	62	64	62	59	55
	MED	780	59	68	67	64	65	64	61	57
	HIGH	820	62	71	69	67	67	67	64	60
HWP 171	LOW	750	55	64	62	59	61	59	56	52
	MED/LOW	880	58	66	65	62	63	61	59	55
	MED	950	61	69	67	65	66	64	62	58
	HIGH	1000	64	73	69	68	69	68	66	63
HWP 191	LOW	1000	58	67	62	60	64	63	60	55
	MED	1050	59	69	64	62	66	65	62	57
	HIGH	1200	61	71	65	65	68	67	64	60
HWP 225	LOW	1000	57	67	66	62	65	62	60	54
	MED	1050	59	69	67	65	66	65	62	57
	HIGH	1200	62	72	69	67	69	68	65	61
HWP 290	LOW	1470	67	76	73	71	74	71	68	66
	MED	1520	68	77	74	72	74	71	70	68
	HIGH	1550	69	78	76	73	75	73	71	69
HWP 291	LOW	1470	67	76	73	71	74	71	68	66
	MED	1520	68	77	74	72	74	71	70	68
	HIGH	1550	69	78	76	73	75	73	71	69
HWP 370	LOW	1900	66	77	77	72	75	71	70	68
	MED	1900	67	78	79	73	75	73	71	69
	HIGH	1900	68	79	81	74	75	73	72	70
HWP 445	LOW	2300	68	78	76	73	75	73	71	69
	MED	2300	69	79	76	74	76	73	72	70
	HIGH	2300	69	79	77	75	76	74	72	70

Water Cooled Air Conditioners

Performance Data



SOUND LEVELS

Note: SPL measured to JIS 8616 (1m from source in an anechoic chamber)

CASE BREAKOUT + RETURN AIR

Model	FAN SPEED	Air Flow (l/s)	SOUND PRESSURE LEVELS (SPL) dB(A)	SOUND POWER LEVELS (SWL) dB						
				SWL dB(A)	OCTAVE BAND FREQ. Hz					
					125	250	500	1k	2k	4k
HWP 141	LOW	650	55	64	68	61	61	59	55	49
	MED/LOW	700	56	65	69	61	61	60	57	50
	MED	780	57	66	70	64	62	62	58	52
	HIGH	820	59	68	71	67	64	63	60	55
HWP 171	LOW	750	58	66	66	61	63	62	58	52
	MED/LOW	880	59	67	68	62	64	64	59	53
	MED	950	60	68	68	64	66	64	61	55
	HIGH	1000	62	70	70	68	67	66	62	57
HWP 191	LOW	1000	56	66	64	59	61	60	60	55
	MED	1050	56	66	64	61	61	61	60	56
	HIGH	1200	57	67	66	62	65	62	61	56
HWP 225	LOW	1000	57	67	72	63	64	62	59	54
	MED	1050	58	68	73	65	66	63	61	55
	HIGH	1200	60	70	74	66	66	66	63	57
HWP 290	LOW	1470	65	74	72	69	70	70	67	61
	MED	1520	65	74	74	70	70	70	68	62
	HIGH	1550	66	75	74	70	71	71	69	63
HWP 291	LOW	1470	64	73	79	72	71	68	65	60
	MED	1520	64	73	79	71	70	67	64	59
	HIGH	1550	63	72	78	71	70	67	63	59
HWP 370	LOW	1900	63	74	79	70	70	69	66	62
	MED	1900	64	75	79	72	71	71	68	64
	HIGH	1900	65	76	82	72	72	72	68	65
HWP 445	LOW	2300	65	75	76	72	71	71	70	63
	MED	2300	66	76	77	73	72	71	70	64
	HIGH	2300	67	77	77	74	73	72	71	64

Water Cooled Air Conditioners

Performance Data



SOUND PRESSURE LEVELS (SPL) WITHIN A ROOM

Deduct the room absorption effect below from Sound Power Levels (SWL) to obtain Sound Pressure Levels within a room.

Note: Occupant at least 1.5 m from sound source.

Room type	OCTAVE BAND FREQUENCY Hz					
	125	250	500	1K	2K	4K
Soft	4	8	11	11	11	11
Medium	3	7	8	9	9	9
Hard	0	1	3	4	4	5

RECOMMENDATIONS FOR NOISE ISOLATION

Particularly for high static installations:

1. Avoid installing units, with non-ducted return air, directly above spaces where noise is critical.
2. Use flexible connections between unit and rigid ducting.
3. Use generously sized acoustically lined ducts.
4. If generous duct size is not possible, use turning vanes on bends to reduce air turbulence (regenerated noise).
5. Use 90° bends in ducting to significantly assist in noise reduction.

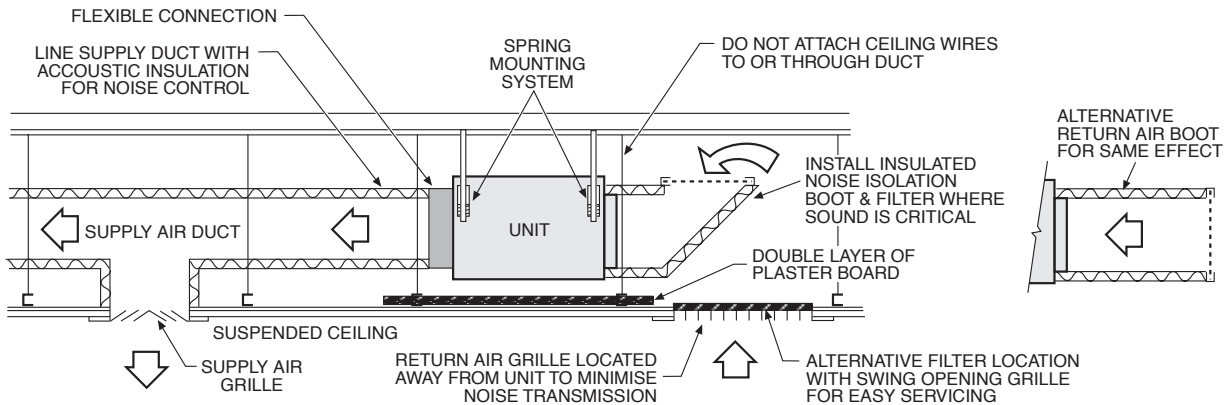
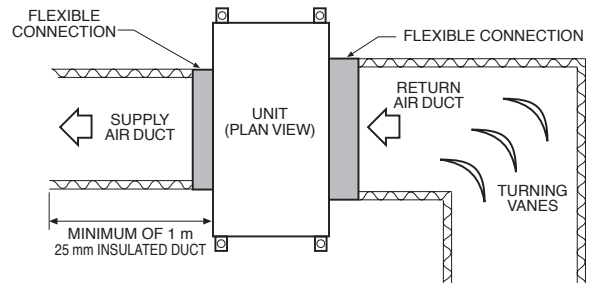

Water Cooled Air Conditioners

Dimensions (mm)



HWP 141

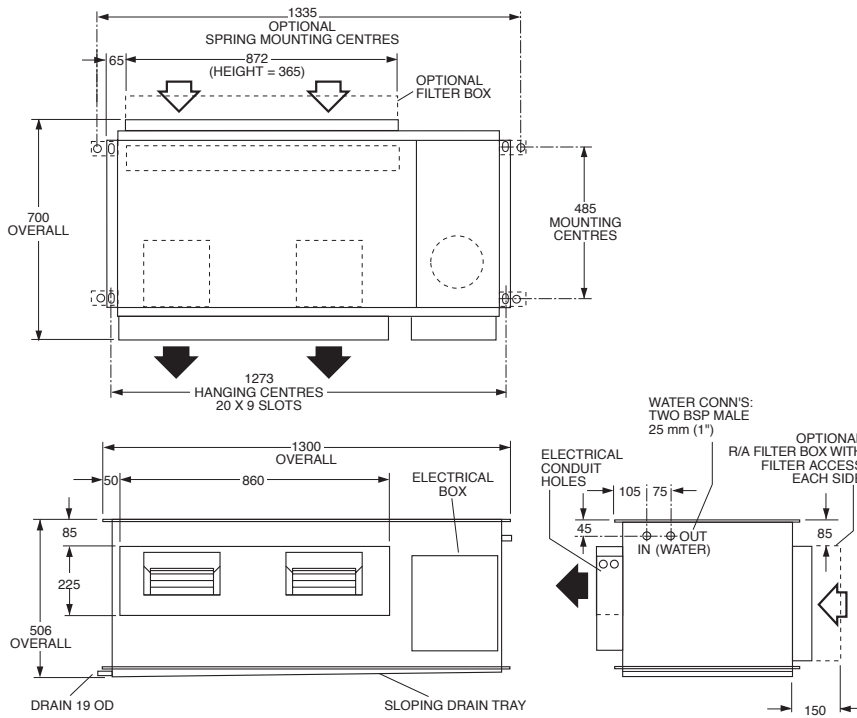

Not to Scale

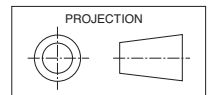

Net Weight 141 kg

HWP 171

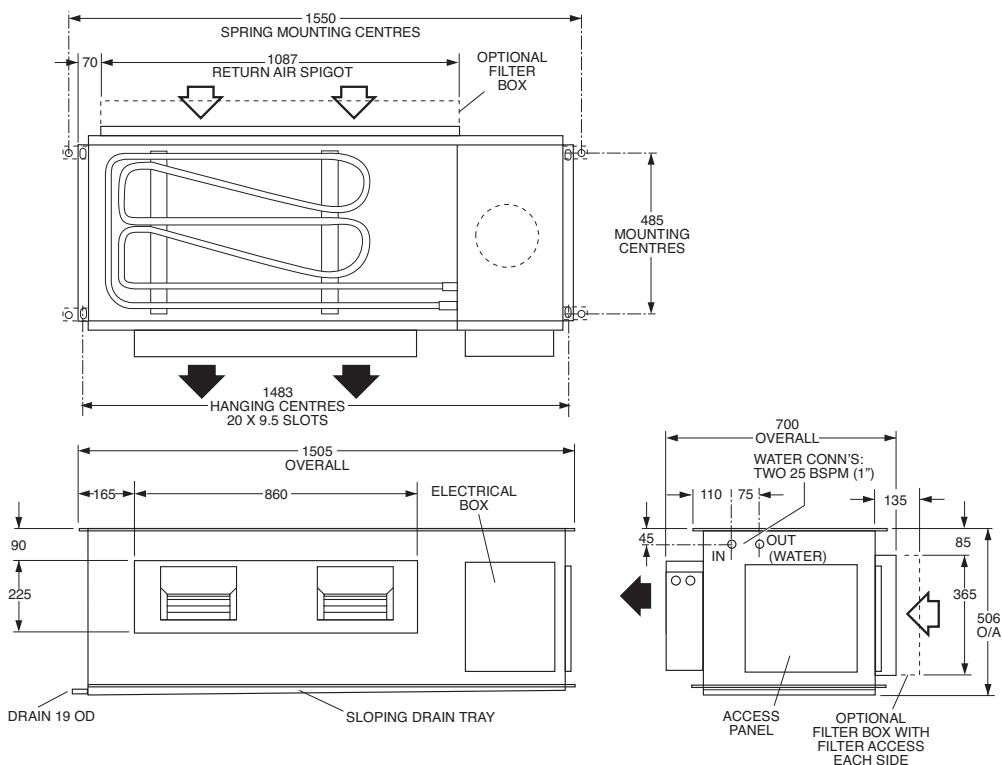

Not to Scale

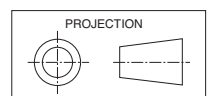

Net Weight 160 kg

Water Cooled Air Conditioners

Dimensions (mm)



HWP 191

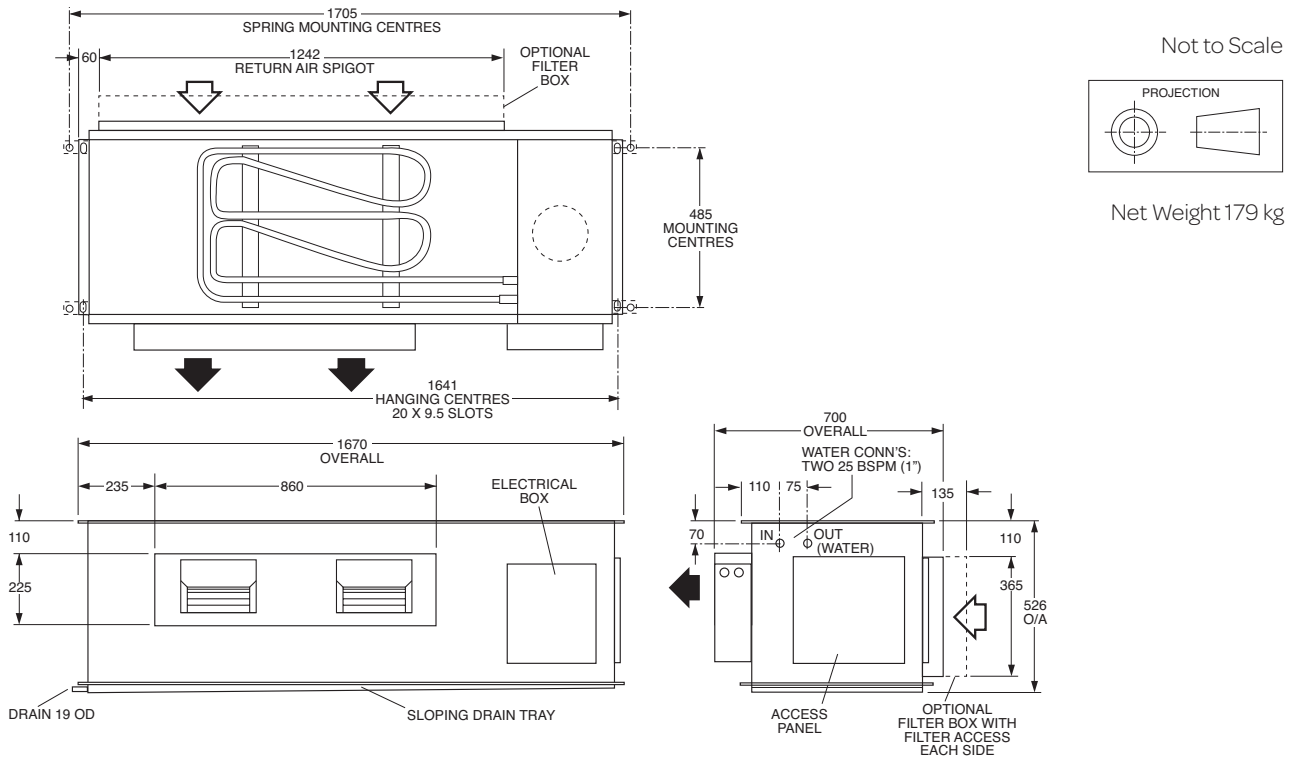

HWP 225

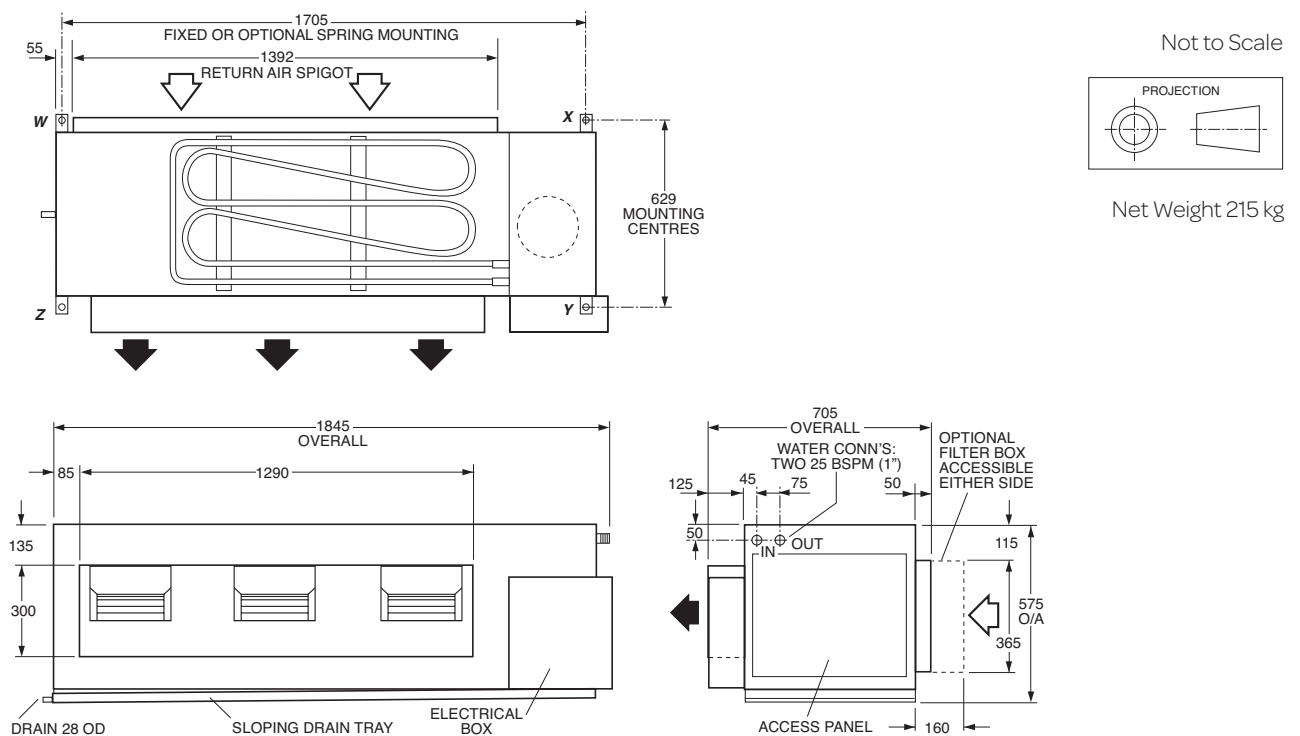

Water Cooled Air Conditioners

Dimensions (mm)



HWP 290

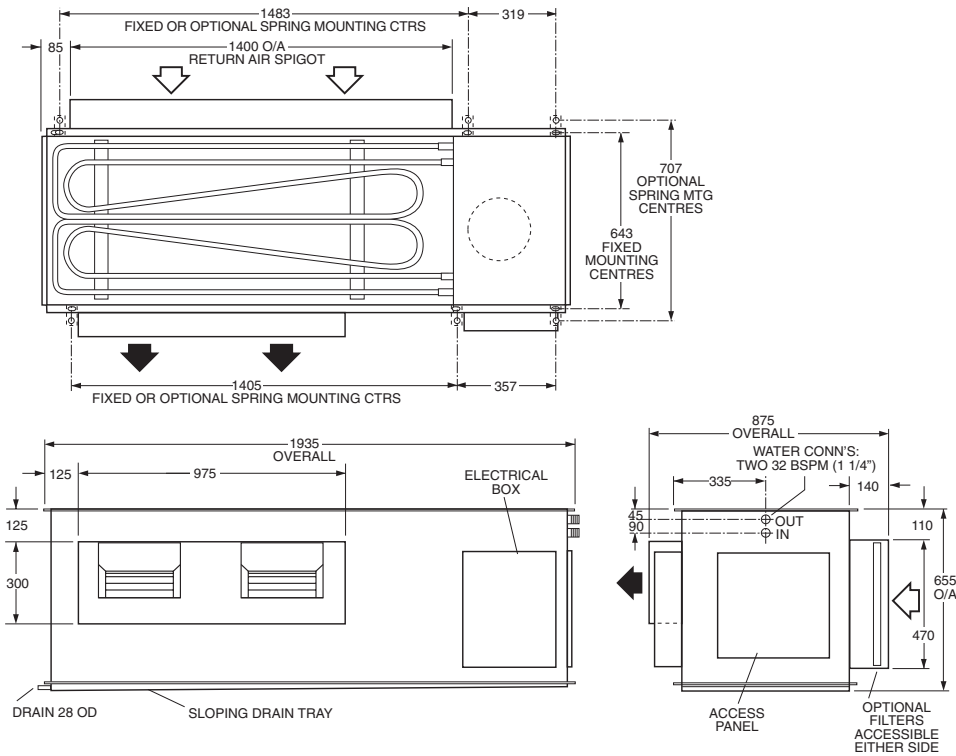

Not to Scale

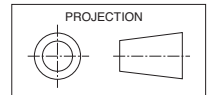

Net Weight 270 kg

HWP 291

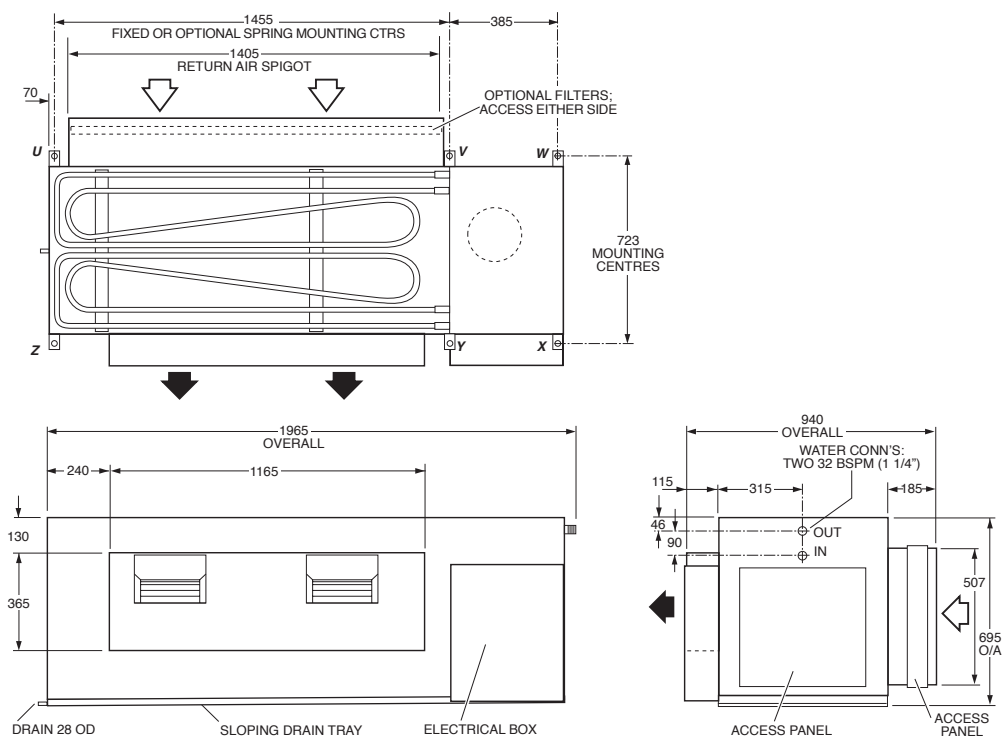

Not to Scale

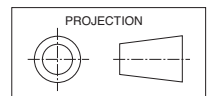

Net Weight 308 kg

Water Cooled Air Conditioners

Dimensions (mm)



HWP 370

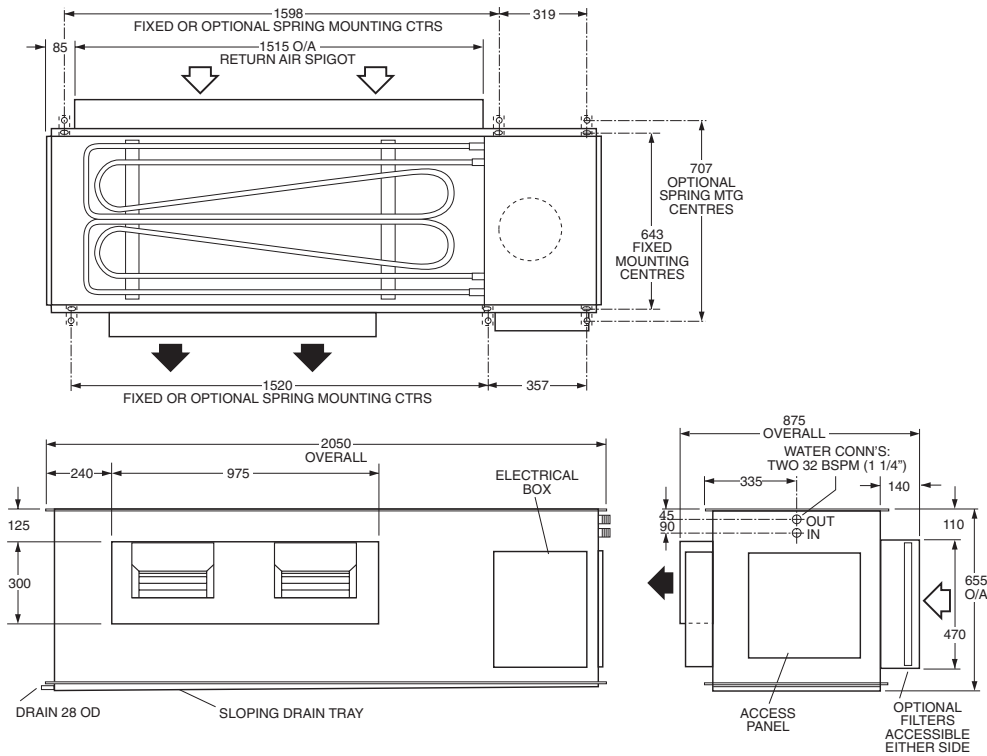

Not to Scale

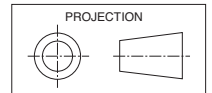

Net Weight 290 kg

HWP 445

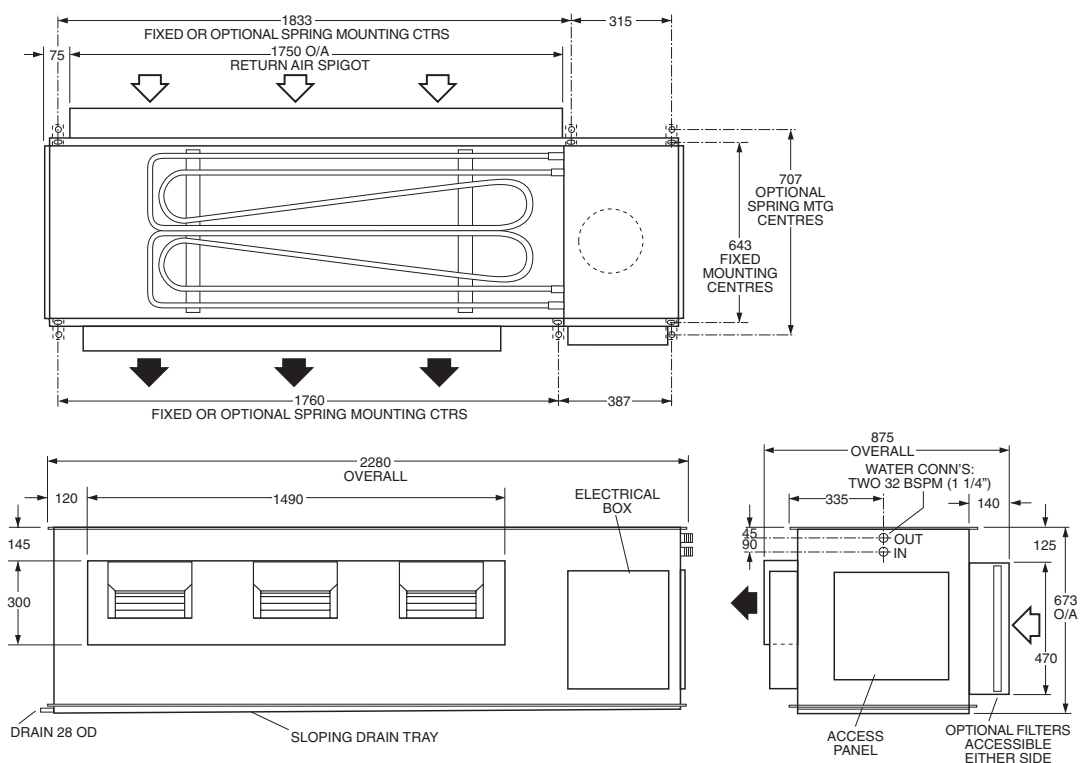

Not to Scale

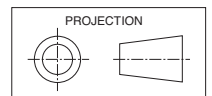

Net Weight 385 kg

Water Cooled Air Conditioners

Specifications



MODEL	HWP141	HWP171	HWP191	HWP225
Nominal Cooling Capacity (kW)	13.6	15.9	18.9	23.1
Net Cooling Capacity* (kW)	13.14	15.3	18.3	22.2
EER / AEER	3.65 / 3.64	3.57 / 3.56	3.59 / 3.58	3.52 / 3.51
Heating Capacity** (kW)	14.7	16.5	18.4	22.3
COP / ACOP	4.37 / 4.36	4.07 / 4.06	4.11 / 4.10	3.85 / 3.84
Optional Electric Heat (kW)	9	9	12	12
Air Flow*** (l/s)	760	1015	1060	1180
Power Supply	3 Phase 400V 50Hz			
Run Current (Amps/Phase)	7.5 / 5.7 / 5.7	9.3 / 7.4 / 7.6	10.6 / 7.7 / 8.0	14.6 / 10.9 / 10.8
Max Run Current (Amps/Phase)	9.4 / 7.6 / 7.6	12 / 10 / 10	13.1 / 10.4 / 10.4	17.7 / 14.7 / 14.5
Refrigerant	R410A			
Nominal Water Flow (l/s)	0.78	0.9	1.17	1.2
Nominal Pressure Drop (kPa)	27.6	41.2	44.9	34.5
Unit Controller	UC7			
Weight (Net) (kg)	141	160	179	215

MODEL	HWP290	HWP291 (Inverter)	HWP370	HWP445
Nominal Cooling Capacity (kW)	28.7	19 ~ 27.7 ~ 31	36.6	44.5
Net Cooling Capacity* (kW)	27.5	27.2	34.65	42.2
EER / AEER	3.60 / 3.59	3.94 / 3.93	3.71 / 3.70	3.41 / 3.41
Heating Capacity** (kW)	28.6	28.5	34.9	42.2
COP / ACOP	3.88 / 3.87	4.28 / 4.26	3.86 / 3.85	3.64 / 3.64
Optional Electric Heat (kW)	18	-	18	24
Air Flow*** (l/s)	1500	1400	1900	2300
Power Supply	3 Phase 400V 50Hz			
Run Current (Amps/Phase)	16.38 / 16.38 / 12.2	17 / 17 / 11.5	18.38 / 18.38 / 14.2	22.98 / 22.98 / 22.98
Max Run Current (Amps/Phase)	19 / 19 / 13.5	22 / 22 / 16.5	21 / 21 / 15.5	26 / 26 / 26
Refrigerant	R410A			
Nominal Water Flow (l/s)	1.5	1.58	2	2.25
Nominal Pressure Drop (kPa)	46.2	48	48.3	34.5
Unit Controller	Protection Board	UC6	Protection Board	Protection Board
Weight (Net) (kg)	270	308	290	385

Note:

* Nominal Cooling Capacity at AS/NZS 3823.1 conditions.
 Entering Air Temperature 27°C db / 19°C wb
 Entering Water Temperature 30°C

** Heating Capacity (HWP-R) at AS/NZS 3823.1 conditions
 Entering Air Temperature 21°C db
 Entering Water Temperature 21°C

*** Airflow at nominal conditions above

Materials and specifications are subject to change without notice due to the manufacturer's ongoing research and development programme.

www.temperzone.biz

AUCKLAND

Head Office

38 Tidal Rd, Mangere, N.Z.
Private Bag 93303, Otahuhu,
NEW ZEALAND.

Email sales@temperzone.co.nz

Phone (09) 279 5250

Fax (09) 275 5637

SYDNEY

Head Office

14 Carnegie Place, Blacktown,
NSW 2148
PO Box 8064, Seven Hills West,
NSW 2147, AUSTRALIA.

Email sales@temperzone.com.au

Phone (02) 8822 - 5700

Fax (02) 8822 - 5711

NEWCASTLE

Phone (02) 4962 - 1155

Fax (02) 4961 - 5101

TOWNSVILLE

Phone (07) 4774 - 3506

Fax (07) 4774 - 3001

WELLINGTON

Phone (04) 569 3262

Fax (04) 566 6249

ADELAIDE

Phone (08) 8115 - 2111

Fax (08) 8115 - 2118

LAUNCESTON

Phone (03) 6331 - 4209

Fax (03) 6333 - 0224

CHRISTCHURCH

Phone (03) 379 3216

Fax (03) 379 5956

MELBOURNE

Phone (03) 8769 - 7600

Fax (03) 8769 - 7601

JAKARTA

Phone +62 (21) 2963 4983

Fax +62 (21) 2963 4984

BRISBANE

Phone (07) 3308 - 8333

Fax (07) 3308 - 8330

SINGAPORE

Phone +65 6733 4292

Fax +65 6235 7180

PERTH

Phone (08) 6399 - 5900

Fax (08) 6399 - 5932

SHANGHAI

Phone +86 (21) 5648 2078



Available from