



# **UNIT CONTROLLER 8 (UC8) Operation Manual**

## **Hydronic Units**

**Date:** 9 May 2017

**Issue:** 3

**Note:** Information in this document applies to UC8 controllers programmed with software version 2.1.9

To find the UC8 software version:  
Turn on mains power to the UC8 controller and observe the display.  
First the display will show the characters "UC8", followed by the software version.

## Contents

1. Connections overview for hydronic units .....	4
2. Input and output signals.....	4
2.1. Mains power .....	4
2.2. Input and output signals .....	4
2.3. Temperature sensor inputs.....	5
2.4. Pressure transducer inputs .....	5
2.5. Water flow verification switch input IN#1 .....	5
2.6. Low pressure switch input IN#2.....	5
2.7. Inputs HI, ME, LO, CAP and HT.....	5
2.8. Remote On/Off input .....	6
2.9. Sump condensate float switch input D1 .....	6
2.10. DRED inputs D2 and D3.....	6
2.11. Variable capacity control input VC (0-10V).....	6
2.12. Variable speed indoor fan control input VF (0-10V).....	7
2.13. Compressor contactor relay output CMC .....	7
2.14. Reverse cycle valve / electric heating contactor relay output R/V.....	7
2.15. Indoor fan / water flow-valve relay outputs HIGH, MED and LOW .....	7
2.16. Water circulating pump request relay output SSR1 .....	8
2.17. Crank case heater relay output SSR2 .....	8
2.18. On-status / damper control relay output AUX.....	8
2.19. Water flow valve relay output (relay 1 on the EXV2 relay output board).....	8
2.20. Sump condensate pump relay output (relay 2 on the EXV2 relay output board) .....	8
2.21. Modbus RTU serial communication slave port.....	9
2.22. Modbus RTU serial communication master port.....	9
2.23. Electronic expansion valve .....	9
3. Digitally communicating thermostats: SAT-3 and TZT-100 .....	9
3.1. Thermostat communication settings.....	10
3.2. Temperzone TZT-100 .....	10
3.3. One temperzone SAT-3 room thermostat .....	11
3.1. Two temperzone SAT-3 room thermostats .....	11
4. Connecting to a communicating BMS.....	12
5. DIP switch selections .....	13
6. UC8 special modes .....	15
6.1. Test mode.....	16
6.2. Commissioning mode.....	16
6.3. Modbus device address selection .....	17
6.4. Modbus communications baud rate selection .....	17
6.5. Modbus communications parity and stop bit selection .....	17

6.6.	Compressor model selection .....	17
6.7.	Carel Power+ configuration .....	17
6.8.	Capacity boost mode options .....	17
6.9.	Supply-air temperature control option.....	18
6.10.	Thermostat auto-on/off options.....	18
7.	Hydronic unit models with electric heating (HWP-CE).....	19
8.	Capacity control for hydronic units with variable speed compressor (inverter) ..	20
8.1.	Capacity control signal .....	20
8.2.	Minimum and maximum capacity .....	20
8.3.	Compressor start-up capacity .....	20
8.4.	Oil recovery (oil flush) cycles .....	20
8.5.	Boost mode .....	21
9.	Dry mode (de-humidification) .....	23
9.1.	Enabling the TZT-100 thermostat for dry mode .....	23
9.2.	Enabling the SAT-3 thermostat for dry mode .....	24
9.3.	Enabling dry mode with a communicating BMS .....	24
9.4.	Operating in dry cooling mode .....	24
10.	Indoor fan control .....	25
10.1.	Variable-speed (EC) indoor fan speed adjustment.....	25
10.2.	Translation from 0-10V fan control input signal VF to a fan output signal .....	27
10.3.	Translation from serial communications fan control signal to fan output signal.....	27
11.	Circulating water control signals and protection .....	28
11.1.	Circulating water pump.....	28
11.2.	Water flow verification switch .....	28
11.3.	Water flow control valve.....	28
11.4.	Protection against freezing of the circulating water .....	28
12.	Display messages.....	29
13.	Troubleshooting .....	30
13.1.	Fault codes .....	31
14.	Specifications .....	34

## 1. Connections overview for hydronic units

The drawing below shows typical connections for hydronic units. Most units do not make use of all input /output signals. Note units with electric heating also use slightly different connections.

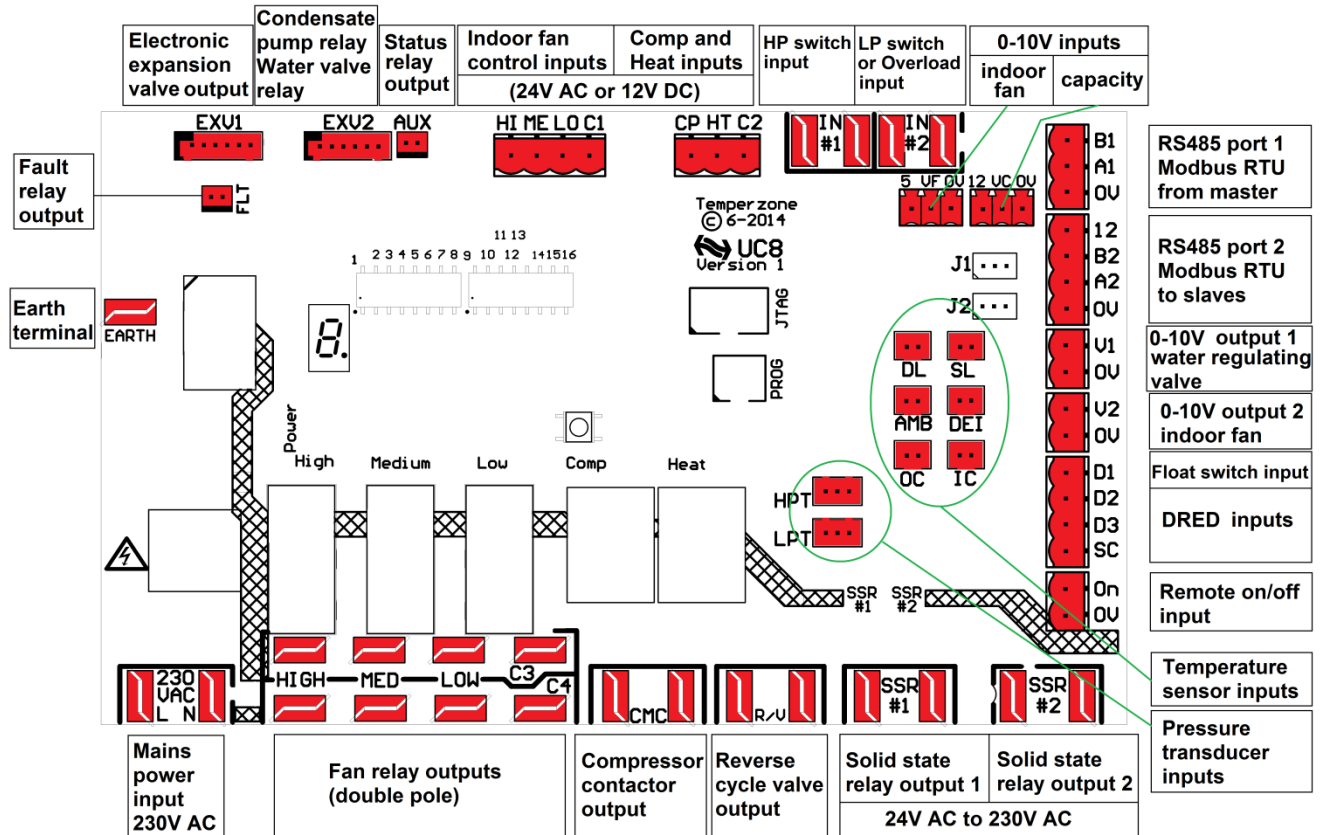

## 2. Input and output signals

### 2.1. Mains power

Connect **230V AC** mains live to terminal **L**, neutral to terminal **N**, earth to terminal **EARTH**.

**NOTE!** The **EARTH** terminal on the UC8 controller board **MUST** always be **directly** connected to the unit earth stud.

### 2.2. Input and output signals

HI, ME, LO, CP and HT:

DL, SL, AMB, DEI, OC, IC:

HPT, LPT:

IN#1, IN#2, D1, D2, D3, On:

VC, VF:

A1, B1, A2, B2:

HIGH, MED, LOW, C3, C4:

CMC, R/V:

SSR#1, SSR#2:

V1 and V2:

EXV1:

AUX, FLT, EXV2:

Control signal inputs, 24V AC or 12V to 24V DC

Inputs for Temperzone standard temperature sensors

Inputs for Temperzone standard pressure transducers

Control signal inputs, dry (voltage free) contact

Control signal inputs, 0-10V analogue

Communication ports, RS485 Modbus RTU

Relay outputs, voltage free dry relay contacts

Relay outputs, voltage free dry relay contacts

Relay outputs, voltage free solid state contacts

Control signal outputs, 0-10V analogue

Output for 12V DC uni-polar electronic expansion valve

Outputs for 12V DC relay coils

**Notes:** The UC8 controller **cannot** accept 230V AC signals on any control input!

All terminals marked "OV" and "SC" are electrically directly connected to the EARTH terminal.

### 2.3. Temperature sensor inputs

Connector	Function	Notes
DL	Compressor discharge line	Red
SL	Compressor suction line	White
AMB	Electric heating safety sensor	Black (units with electric heating element only)
DEI	Supply-water	Blue (optional, reverse cycle units only)
OC	Water heat exchanger	Yellow (optional)
IC	Indoor coil	Yellow

### 2.4. Pressure transducer inputs

Most hydronic units have a high pressure transducer connected to input HPT but do not have a low pressure transducer. On these models, if a reverse cycle model, the high pressure transducer connects to the compressor discharge line when cooling and to the compressor suction line when heating.

The low pressure transducer is optional. If a low pressure transducer is used then the high pressure transducer must remain connected to the compressor discharge line regardless whether the unit is cooling or heating.

Connector	Function	Default pressure range	Output voltage
HPT	High pressure	0 to 4500kPa (all models)	0.5 to 4.5V
LPT	Low pressure	0 to 3450kPa (all models, if fitted)	0.5 to 4.5V

### 2.5. Water flow verification switch input IN#1

Use of a water flow verification switch is recommended. The signal from a flow switch must provide voltage-free dry contacts and can connect directly to the IN#1 terminals. The switch contacts must close when water flow is adequate. If no flow switch is used then the terminals of input IN#1 must be shorted (looped).

### 2.6. Low pressure switch input IN#2

Use of a low pressure switch is optional. Refer to the following table.

Low pressure transducer	LP switch	IN#2 terminals
No	No	Short circuit (loop).
No	Yes	Connect to low pressure switch.
Yes	No	Short circuit (loop).

### 2.7. Inputs HI, ME, LO, CAP and HT

A thermostat or other controller with voltage-free contact outputs can be used to switch 24V AC or 12V to 24V DC signals to the following inputs:

- CP Compressor on/off
- HT Cooling / heating (leave unconnected for cooling-only installations)
- HI – ME – LO For a three-speed or variable speed indoor fan
- HI For a single-speed indoor fan
- C1 Common for inputs HI, ME and LO.
- C2 Common for inputs CP and HT.

Common inputs C1 and C2 should connect to the 24V AC Common (or to 0V when using 12V DC control signals). These inputs are electrically isolated from all other circuits.

## 2.8. Remote On/Off input

A remote on/off signal can be connected to the “On” and “0V” terminals (input for a voltage-free switch or relay contact). To turn the unit **on** the remote on/off input must be **closed-circuit**.

If no remote On/Off function is needed then the terminals must be connected (looped).

When the unit is off by the remote on/off signal the display will show a slowly flashing – symbol.

The remote on/off input cannot override the compressor minimum run-time of 90 seconds.

When the remote on/off input is used in combination with a SAT-3 or TZT-100 thermostat then refer to chapter 6.10: Thermostat auto-on/off options.

## 2.9. Sump condensate float switch input D1

Input D1 accepts a signal from a sump condensate float switch. The float switch must provide voltage-free dry contacts and connect directly to terminals D1 and SC. The contacts must be normally closed when the sump is dry.

If no float switch is used then short circuit (loop) terminals D1 and SC.

Terminal SC is internally directly connected to terminals labelled ‘0V’ and the unit EARTH terminal.

## 2.10. DRED inputs D2 and D3

DRED stands for Demand Reduction Enabling Device. The UC8 can be connected to such a device, which typically is controlled by the electricity supplier.

When used, inputs D2 and D3 should connect to two ‘voltage free’ dry relay contacts in accordance with the DRED standard. Terminal SC is the common for the two inputs. When not used leave inputs D2 and D3 open circuit.

Functionality is as follows:

- Input D2 active: Average energy consumption of the unit is reduced by 50% (approximately).
- Input D3 active: Average energy consumption of the unit is reduced by 25% (approximately).

Terminal SC is internally directly connected to terminals labelled ‘0V’ and the unit EARTH terminal.

## 2.11. Variable capacity control input VC (0-10V)

A hydronic unit with a variable speed compressor (inverter) can provide variable capacity (duty). Capacity can be controlled by applying a 0-10V analogue signal to input VC as follows:

- 0 to 3.0V - Minimum capacity
- 3.0V to 7.5V - Capacity varies linearly from minimum (3.0V) to nominal (7.5V)
- 7.5V to 10V - Nominal (rated) capacity

It is possible to configure the unit to deliver capacity higher than nominal. For more information refer to chapter 6.8.

### Notes:

- 0-10V input VC is directly referenced to unit earth, it is not electrically isolated.
- Terminal “0V” is the reference (return) connection and is directly connected to the controller EARTH terminal.
- If the 0-10V control signal source is located remotely from the unit then it may be necessary to use a suitable 0-10V isolating amplifier.

**2.12. Variable speed indoor fan control input VF (0-10V)**

Analogue input VF (0-10V) provides an optional method to control indoor fan speed. This applies regardless of the type of the indoor fan (1- speed, 3- speed or variable speed). For more information refer to chapter 10.

**Notes:**

- 0-10V input VF is directly referenced to unit earth, it is not electrically isolated.
- Terminal “0V” is the reference (return) connection and is directly connected to the controller EARTH terminal.
- If the 0-10V control signal source is located remotely from the unit then it may be necessary to use a suitable 0-10V isolating amplifier.

**2.13. Compressor contactor relay output CMC**

The two terminals labelled CMC are one set of normally-off relay contacts, fully isolated from all other circuits and voltage-free.

On units with a fixed capacity compressor terminals CMC are used to control the compressor contactor.

On units with a variable speed compressor (inverter) terminals CMC can be left unconnected.

**2.14. Reverse cycle valve / electric heating contactor relay output R/V**

The two terminals labelled R/V are one set of normally-off relay contacts, fully isolated from all other circuits and voltage-free.

**Cooling-only units (HWP-C models):**

Terminals R/V can be left unconnected.

**Reverse cycle units (HWP-R models):**

Terminals R/V control the reverse cycle valve. The refrigeration circuit must be designed with reverse cycle valve OFF for cooling mode, ON for heating mode.

**Units with electric heating element (HWP-CE models):**

Terminals R/V control electric heater contactor number 1 (EHC1).

**2.15. Indoor fan / water flow-valve relay outputs HIGH, MED and LOW**

Terminals labelled HIGH, MED and LOW connect to three double-pole normally-off relay contacts.

Terminal C3 is the common terminal for the upper row of terminals.

Terminal C4 is the common terminal for the lower row of terminals.

The two sets of contacts are voltage free and fully isolated from all other circuits.

These terminals can be assigned a number of functions. The table below lists the available combinations:

Indoor fan type	UC8 relay function		
	HIGH	MED	LOW
1- speed	Indoor fan on/off	-	Water flow valve
3- speed	Indoor fan high	Indoor fan medium	Indoor fan low
variable speed (0-10V EC)	Indoor fan contactor	-	Water flow valve

### **2.16. Water circulating pump request relay output SSR1**

Solid state relay output SSR1 can be used for control of a water circulating pump. Output SSR1 activates whenever the compressor is on and/or there's a compressor run request. Refer to chapter 11.1.

If the circulating pump is not controlled by the UC8 then the terminals can be left unconnected.

### **2.17. Crank case heater relay output SSR2**

#### **Models without electric heating element (HWP-R and HWP-C):**

Solid state relay output SSR2 can be used for control of a compressor crank case heater.

#### **Models with electric heating element (HWP-CE):**

Solid state relay output SSR2 controls the second electric heating contactor (EHC2).

### **2.18. On-status / damper control relay output AUX**

When used output AUX must connect to the coil of an external relay rated for 12V DC. The relay contacts can then be used for the following two functions:

1. If the unit is connected to **two** SAT-3 room thermostats the output is active when thermostat "2" is on, otherwise it is off. The signal is intended for control of supply-air dampers. Refer to chapter 3.1.
2. If the unit does not connect to two SAT-3 room thermostats the AUX output provides an "On-status" signal. The output is active when one or more of the following conditions apply:
  - The compressor is on.
  - The indoor fan is on.
  - The compressor and indoor fan are currently off but the thermostat is on, thus the unit is off in deadband or the compressor may be held off by an internal safety timer or by a protection function.

### **2.19. Water flow valve relay output (relay 1 on the EXV2 relay output board)**

If a hydronic unit has an indoor fan with three-speed induction motor then the LOW relay output is not available for control of an open/close water flow valve. In this case a water flow valve can be controlled using terminals labelled "RELAY1" on the EXV2 relay output board. These relay contacts are voltage-free and fully isolated from other circuits. Refer to chapter 11.3.

If the installation does not require a water flow valve the terminals can be left unconnected.

### **2.20. Sump condensate pump relay output (relay 2 on the EXV2 relay output board)**

For hydronic units that require a sump condensate pump this pump can be controlled using terminals labelled "RELAY2" on the EXV2 relay output board. On most models the relay contact is connected to the mains live terminal, refer to the unit wiring diagram.

The condensate pump is activated automatically when the unit operates in cooling mode and also when the sump float switch activates. To remove as much water from the sump as possible the pump continues to run for 15 minutes after the unit has stopped cooling and after the float switch de-activates.

If the installation does not require a condensate pump the terminals can be left unconnected.



### 2.21. Modbus RTU serial communication slave port

Terminals A1 and B1 provide a serial communications port for a building management system (BMS) to monitor and/or control the unit. The communications protocol is Modbus RTU and the signals follow the RS485 standard. On this port the UC8 always acts as a Modbus slave device. The RS485 signal reference is terminal 0V, which connects directly to unit earth.

If the unit makes use of BACnet/IP communications then this port must connect to the Modbus-to-BACnet gateway module. Refer to chapter 4.

### 2.22. Modbus RTU serial communication master port

Terminals A2 and B2 provide a serial communications port for a room thermostat and for the compressor driver in a unit with inverter compressor. The communications protocol is Modbus RTU and the signals follow the RS485 standard. On this port the UC8 always acts as a Modbus master device. Refer to chapter 4.

The RS485 signal reference is terminal 0V, which connects directly to unit earth.

Terminals “0V” (-) and “12” (+) provide 12V DC power that can be used to power the room thermostat.

### 2.23. Electronic expansion valve

The UC8 can control one electronic expansion valve via output EXV1. The expansion valve must be a 12V unipolar type. The connector must be compatible with type XH (manufactured by JST) and have 6 pins.

DIP switches 7 and 8 on UC8 board define the operation of output EXV1, switches 9 and 10 select the expansion valve model. Refer to chapter 5: DIP switch selections.

Below are images that can help to identify the correct expansion valve in the unit:



Dunan



Zhe Jiang Sanhua



Carel

## 3. Digitally communicating thermostats: SAT-3 and TZT-100

A hydronic unit can connect to one or two temperzone SAT-3 room thermostats or to one temperzone TZT-100 room thermostat.

It is recommended to use a shielded cable with at least one twisted pair wires. Signals from UC8 terminals **A2** and **B2** must form one twisted wire pair. The cable shield should connect to terminal “0V” at the UC8.

12V DC power is available on terminals “0V” (-) and “12” (+) and can be used to power the thermostat. If the cable length between the UC8 and thermostat is greater than about 20m and communications do not work or are intermittent then place UC8 jumper “J2” on the centre and left pins, otherwise place jumper “J2” on the centre and right pins.

For best reliability it is recommended to separate the thermostat cable from other building cabling as much as is practical. When the UC8 and room thermostat are communicating correctly a small “satellite dish antenna” symbol is visible on the thermostat display:



### 3.1. Thermostat communication settings

The communications format must be set in accordance with Modbus RTU standard settings:

- Baud rate 19200
- 8 Data bits
- Even parity bit
- 1 Stop bit
- Tzt-100 modbus device address 7
- SAT-3 modbus device address 8
- If two SAT-3 thermostats are used then the second thermostat must be set to address 9
- The Tzt-100 or SAT-3 thermostat should be configured for 1-stage operation

Refer to the thermostat installer manual for procedures to check and adjust the settings in the SAT-3 or Tzt-100 thermostat.

### 3.2. Temperzone Tzt-100

DIP switch 4 inside the Tzt-100 must be **ON**: Reverse cycle valve = On when Heating  
 If DIP switch 4 is in the OFF position the UC8 will report fault code F36. All other DIP switches inside the Tzt-100 thermostat can be set as required for the installation.

Connections to the Tzt-100 room thermostat are shown below.

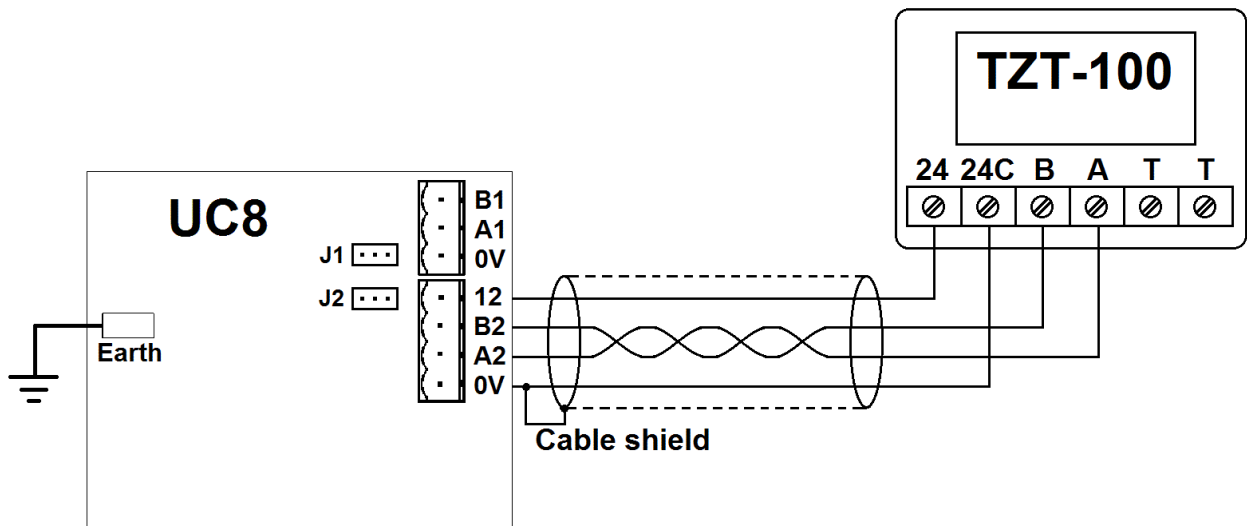

The Tzt-100 thermostat can also be powered by an **isolated** 24V AC power source as shown below:

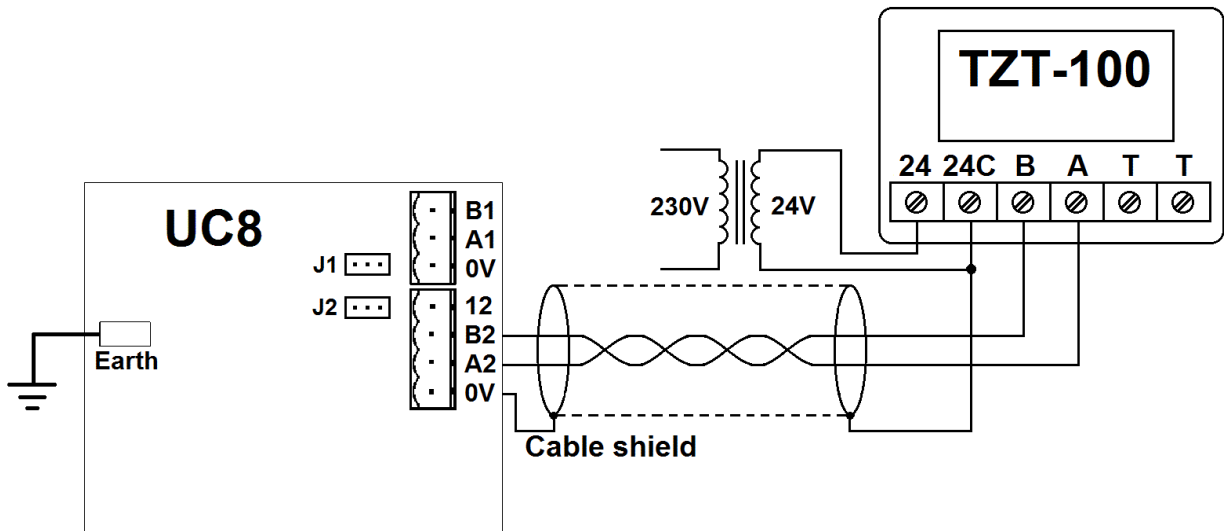

### 3.3. One temperzone SAT-3 room thermostat

Connections to one SAT-3 room thermostat are shown below.

**Note:** The SAT-3 thermostat **cannot** be powered with 24V AC!

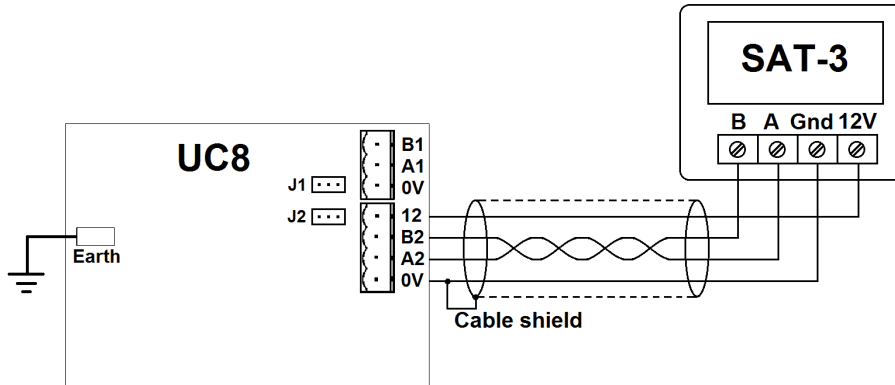

### 3.1. Two temperzone SAT-3 room thermostats

Connections to two SAT-3 room thermostats are shown below.

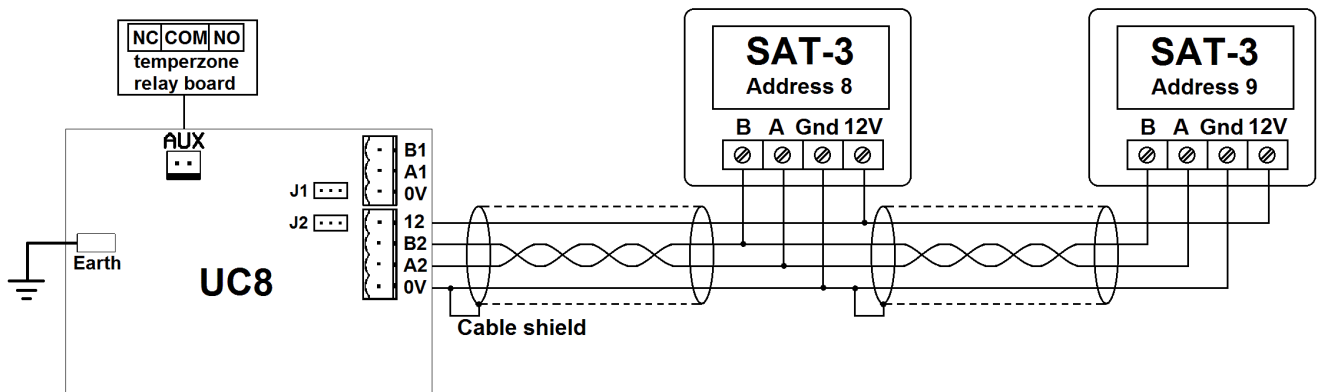

A temperzone relay board can be connected to UC8 output AUX. The relay board provides a set of voltage-free relay contacts, capable of switching 12V DC or 24V to 240V AC. The relay is switched **on** only when the **second** SAT-3 thermostat is on (thermostat with Modbus address 9, otherwise the relay is off). The relay contacts are intended to operate a set of dampers that direct supply-air to appropriate parts of the building.

Operation with two SAT-3 room thermostats is as follows:

- The system is off when both thermostats are off.
- Only one thermostat can be on at any time.
- If a thermostat is on and the other thermostat is switched on (either manually or by timer) then the first thermostat is automatically switched off.
- When a thermostat is switched off (manually, by timer or because the other thermostat is switched on) the last-used settings are retained and these settings will be used the next time the thermostat is switched on again off (timer settings can overrule).
- If a thermostat is automatically switched off when the other thermostat switches on, then that thermostat will automatically switch back on when the other thermostat switches off (timer settings can overrule).

Apart from switching on & off in all other respects the two thermostats operate fully independently; this means settings are not copied between the two thermostats. For example setpoints, fan speeds, heating and cooling settings, timers: all can be set differently.

#### 4. Connecting to a communicating BMS

The UC8 provides a serial communications port (terminals A1 & B1) for RS485 type signals and wiring. Full monitoring and control is available through this port. The communications protocol used is Modbus RTU.

Also possible is monitoring and control using BACnet/IP via a standard computer network using Ethernet wiring. The BACnet/IP option requires the addition of a Modbus-to-BACnet gateway module.

BACnet-MS/TP is currently not available.

For more information refer to documents “Temperzone UC8 – Modbus RTU serial communications” or “Temperzone UC8 – BACnet/IP serial communications”.

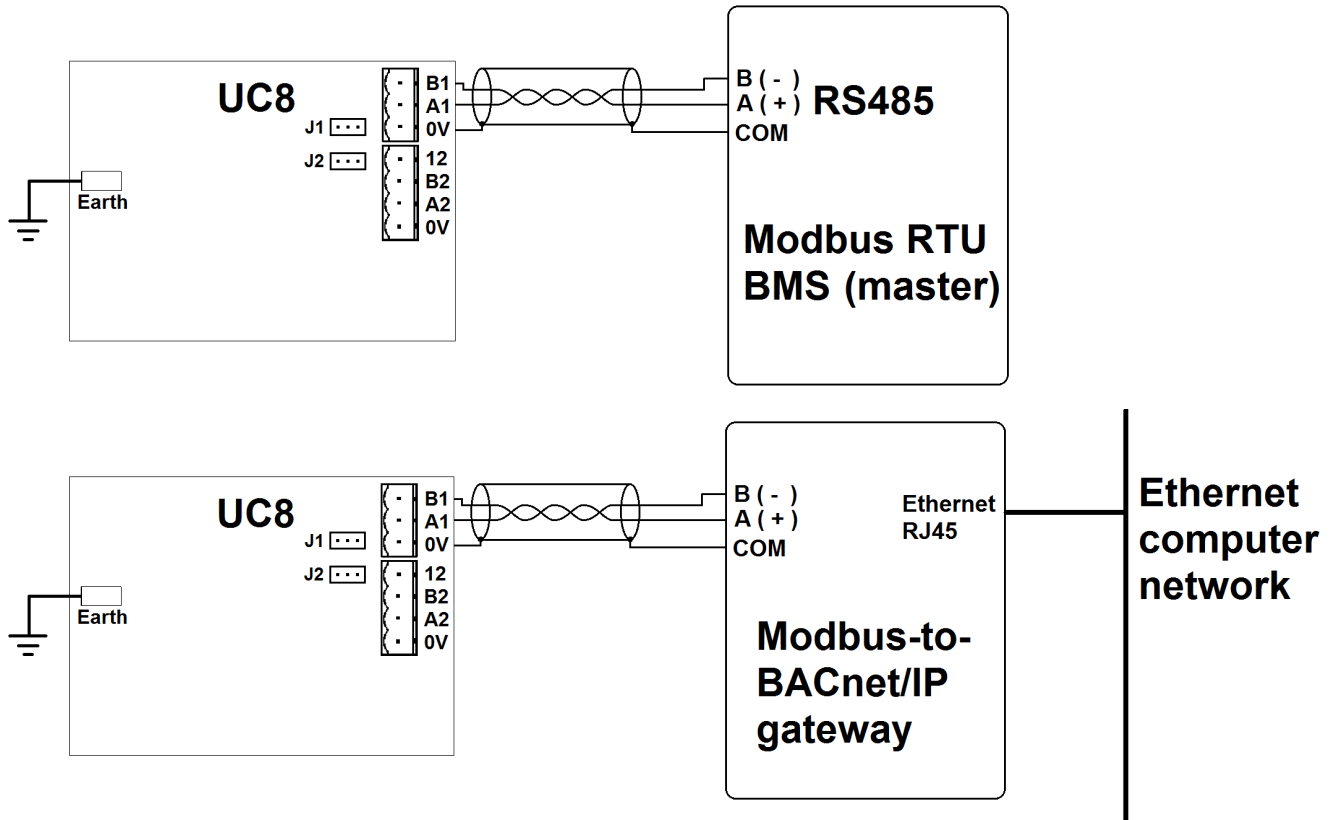

## 5. DIP switch selections

Switch		Function
<b>1</b>		<b>Indoor air flow</b>
<b>OFF</b>		Variable indoor air flow: Indoor fan performs a warm start when unit starts heating (to minimise cold drafts). Indoor fan speed may vary from thermostat request (to optimise unit performance).
<b>ON</b>		Fixed indoor air flow: Indoor fan follows thermostat request even when heating starts. Indoor fan speed follows thermostat request
		Note: At all times the UC8 may alter indoor fan speed if the unit is operating outside safe limits.
<b>2</b>		<b>Compressor type</b>
<b>OFF</b>		Fixed capacity or variable speed compressor (inverter).
<b>ON</b>		Reserved, <b>do not select</b> .
<b>3</b>		<b>Thermostat type</b>
<b>OFF</b>		Thermostat provides <b>COMP &amp; HEAT</b> signals (reverse cycle heatpump type).
<b>ON</b>		Thermostat provides <b>COOL &amp; HEAT</b> signals (often used on models with electric heating element).
<b>4</b>		<b>Hydronic unit type</b>
<b>OFF</b>		<b>Reverse cycle or cooling-only unit.</b> For cooling-only units: Leave input HEAT unconnected. On a controlling thermostat disable heating mode.
<b>ON</b>		<b>Cooling + electric heating unit.</b>
<b>5</b>	<b>6</b>	<b>Indoor fan selection</b>
<b>OFF</b>	<b>OFF</b>	3- Speed fan      HIGH/MED/LOW relay outputs
<b>ON</b>	<b>OFF</b>	1- Speed fan      HIGH relay output
<b>OFF</b>	<b>ON</b>	Variable speed fan    V2 output (speed) and HIGH relay (contactor, use is optional)
<b>ON</b>	<b>ON</b>	Reserved, <b>do not select</b> .

Continued on the next page.

DIP switch settings, continued.

Switch		Function	
<b>7</b>	<b>8</b>	<b>Electronic expansion valve operating mode</b>	
<b>OFF</b>	<b>OFF</b>	No electronic expansion valve (e.g. accurators, capillary tube).	
<b>ON</b>	<b>OFF</b>	One valve electronic expansion valve.	
<b>OFF</b>	<b>ON</b>	Reserved, <b>do not select.</b>	
<b>ON</b>	<b>ON</b>	Reserved, <b>do not select.</b>	
<b>9</b>	<b>10</b>	<b>Electronic expansion valve type</b>	<b>How to recognise the valve type</b>
<b>OFF</b>	<b>OFF</b>	Dunan DPF series.	removable black coil
<b>ON</b>	<b>OFF</b>	Zhe Jiang Sanhua DPF series.	non-removable metal coil
<b>OFF</b>	<b>ON</b>	Carel E2V series (& E3V series with uni-polar coil).	removable red coil
<b>ON</b>	<b>ON</b>	Reserved, <b>do not select.</b>	-

<b>11</b>	<b>Models with electric heating element (HWP-CE)</b>		
<b>OFF</b>	No modulation of the electric heating element		
<b>ON</b>	Modulate the electric heating element: enables variable heating duty (use only when contactor EHC2 is a solid state type)		
<b>12</b>	<b>Reserved</b>		
<b>OFF</b>	Do not select any other setting.		

<b>11</b>	<b>12</b>	<b>Models without electric heating element (HWP-R and HWP-C)</b>	
<b>OFF</b>	<b>OFF</b>	Do not select any other setting.	

<b>13</b>	<b>14</b>	<b>15</b>	<b>16</b>	Hydronic unit (water to air, HWP). All other combinations for DIP switches 13 to 16 are reserved, <b>do not select.</b>
<b>ON</b>	<b>ON</b>	<b>OFF</b>	<b>OFF</b>	

## 6. UC8 special modes

The UC8 offers a number of modes that allow the factory, installer and service technician to make some changes to the operation of the UC8.

UC8 special modes are selected as follows:

- Apply power to the unit and wait until the power-on sequence is completed.
- The compressor must be off and there must be no request to start (CP signal or thermostat must be OFF, no Modbus RTU or BACnet/IP run request).
- Hold down pushbutton SW3 until the display shows the specific letter for the required configuration mode, then release the button.
- The selected mode starts immediately after the button is released. During the configuration mode use the display and pushbutton to make changes to the settings of the UC8.
- The configuration mode automatically ends when the pushbutton has not been pressed for 30 seconds. Exceptions are commissioning mode which lasts up to 30 minutes, and forced de-ice mode which lasts until ice has been successfully removed from the outdoor coil (maximum 10 minutes).
- When a setting has been changed during a configuration mode, then the controller saves the change in memory which is kept even when power is switched off. Thus changes need to be made only once (test and commissioning modes excluded).

UC8 special modes for hydronic units are:

Special mode	Displayed symbol	Chapter
Test	<b>t</b>	
Commissioning	<b>c</b>	
EC indoor fan high speed adjustment	<b>H</b>	
EC indoor fan low speed adjustment	<b>L</b>	
Modbus device address selection	<b>A</b>	* Note
Compressor model selection	<b>E</b>	
Supply-air temperature control selection	<b>Y</b>	
Modbus baud rate selection	<b>b</b>	* Note
Modbus parity and stop bit selection	<b>P</b>	
Thermostat auto-on/off selection	<b>o</b>	
Capacity boost mode limiting selection	<b>u</b>	

For detailed information on the special modes refer to the chapters listed in the table above.

\* Note: Refer to document Temperzone UC8 – Modbus communications.

## 6.1. Test mode

To activate test mode hold down pushbutton SW3 until the display shows the letter 't', then release the button. Test mode will start immediately. During test mode the following outputs are activated one by one in the order indicated below, with a brief pause between each step:

Output	Function	Duration
• R/V	Reverse cycle valve or EHC1	2s
• Water valve	0-10V type water valve connected to output V1	29s
• LOW-MED-HIGH	Indoor fan	low 7s, medium 7s, high 15s
• SSR1	Water circulating pump	2s
• SSR2	Crank case heater	2s
• AUX	Unit On status / damper control	2s
• CMC	Compressor contactor	2s

If the unit has high and low pressure transducers then the pressure readings from the two sensors is compared before test mode completes. The two pressure readings are expected to be approximately equal. If the two pressure readings are found to be very different then fault F34 will be reported. The pressure comparison is then repeated every 60 seconds and fault F34 is cleared when pressures have equalised sufficiently.

When the test sequence is complete the UC8 returns to normal mode and the display will show the compressor suction line pressure (letters SLP followed by the pressure in kPa), if known.

## 6.2. Commissioning mode

To activate commissioning mode hold down pushbutton SW3 until the display shows the letter 'C', then release the button.

Commissioning mode starts immediately and ends automatically after 30 minutes. It is also possible to manually end commissioning mode either by cycling mains power off and on again, or by pressing the pushbutton until the display again shows the letter 'C' and then release. When commissioning mode ends the UC8 returns to normal mode.

During commissioning mode some delay times are reduced:

- Minimum On-Off time ('Run'-time) 20 seconds (\* note)
- Minimum Off-On time ('Off'-time) 20 seconds
- Minimum On-On time ('Cycle'-time) 1 minute (\* note)
- Cooling to heating change-over time 1 minute
- Heating to cooling change-over time 1 minute

\* Note:

If the unit has a variable speed compressor then the Minimum On-Off time ('Run'-time) remains set to 1 minute and 30 seconds regardless whether the controller is placed in commissioning mode or not.



### 6.3. Modbus device address selection

The default Modbus RTU device address of the temperzone UC8 controller is **44**.  
To change the setting refer to document “*Temperzone UC8 – Modbus communications*”.

### 6.4. Modbus communications baud rate selection

The default Modbus RTU communication speed is **19200 baud**.  
To change the setting refer to document “*Temperzone UC8 – Modbus communications*”.

### 6.5. Modbus communications parity and stop bit selection

The default Modbus RTU communication parity setting is **EVEN** with **1** stop bit.  
To change the setting refer to document “*Temperzone UC8 – Modbus communications*”.

### 6.6. Compressor model selection

When mains power is applied to the controller the UC8 display shows the selected compressor. The default setting is for fixed capacity- and digital scroll- compressor (option ‘dF’).

To change the compressor model hold down pushbutton SW3 until the display shows the letter ‘E’, then release the button.

The UC8 supports the following compressor types, models and variable speed drives:

Compressor	Drive	UC8 display indication
Fixed capacity	Not required	<b>dF</b>
Copeland ZPV038	Carel Power+ PSD1024400	<b>038</b>
Toshiba DA550	Carel Power+ PSD1018400 or PSD1024400	<b>550</b>
Siam ANB66	Carel Power+ PSD1024400	<b>66</b>
Siam ANB78	Carel Power+ PSD1024400 or PSD1035420	<b>78</b>
Siam ANB87	Carel Power+ PSD1035420	<b>87</b>
Other inverter	Type with 0-10V input	<b>010</b>
Do not select any other compressor model for hydronic units.		

### 6.7. Carel Power+ configuration

The four DIP switches inside the Power+ compressor drive (inverter) must be set as follows:

- 1 and 4 ON
- 2 and 3 OFF

To access the Power+ DIP switches the plastic front cover must be carefully removed.  
The UC8 takes care of other drive configurations via RS485 Modbus communications.

### 6.8. Capacity boost mode options

Refer to chapter 8.5.

## 6.9. Supply-air temperature control option

Units with a variable speed compressor (inverter) can provide automatic control of the supply-air temperature. To configure for supply-air temperature control hold down UC8 pushbutton SW3 until the display shows the letter 'Y', then release the button. The display will then show 0 or 1. Use the pushbutton to select the desired configuration:

- **0** : Disable supply-air temperature control (default value)
- **1** : Enable supply-air temperature control

Note:

Temperzone hydronic units do not directly measure the supply-air temperature. When supply-air temperature control is enabled the controller will regulate evaporating temperature (when cooling) or condensing temperature (when heating).

## 6.10. Thermostat auto-on/off options

The UC8 can be configured to automatically switch the SAT-3 and TZT-100 thermostat on and off synchronised with the remote on/off input terminal of the UC8 circuit board. To enable or disable this feature hold down pushbutton SW3 until the display shows the letter 'O', then release the button. The display will then show 0, 1 or 2. Use the pushbutton to select the desired option:

- **0** : Thermostat automatic on/off is disabled (default).
- **1** : Thermostat automatic on/off is enabled.
- **2** : Thermostat automatic on/off is enabled, the unit automatically starts in cooling mode every time the UC8 remote on/off signal changes from off to on.

### **Option 0 (default):**

The auto-on/off feature is disabled. This means that a SAT-3 or TZT-100 thermostat that is switched on can show that a unit is active (cooling, heating or fan-only) even when the unit is actually off because the UC8 remote on/off terminal is made inactive (open-circuit).

### **Option 1\*:**

The thermostat shows the actual state of the unit. In this case when a thermostat is on and the UC8 remote on/off signal becomes inactive (open circuit) the thermostat is automatically switched off. While the UC8 remote on/off signal remains inactive the thermostat is held off, pressing the thermostat on/off button is overruled by the UC8 off-command. When the UC8 remote on/off signal becomes active again then the thermostat resumes operation with the same settings that were valid when last active.

### **Option 2:**

This mode is intended for use only on **cooling-only** installations; it is unsuitable for installations that also require operation in heating mode. The thermostat is forced to remain off when the UC8 remote-on/off input is inactive. When the UC8 remote on/off signal becomes active the thermostat is automatically switched on in cooling mode.

**\* IMPORTANT note for option 1:** If power is removed from the unit while the unit is switched off by the remote on/off signal, then the thermostat will power up in the OFF-state. *The unit will NOT resume operation in the last active mode!* If it is essential that the unit must always come back on after a power-cut then the unit must be configured for option 0 (feature disabled) or option 2 (cooling starts automatically).

## 7. Hydronic unit models with electric heating (HWP-CE)

Hydronic units with an electric heating element must have DIP switch 4 set to the ON position. These units are equipped with:

- Two contactors (EHC1 and EHC2) that control mains power to the heating element. Some models use a solid-state relay (SSR) for EHC2.
- Two mechanical temperature safety switches either of which can disable the heating element.
- A fast-acting temperature sensor placed directly above the heating element and connected to input AMB on the UC8.

Contactors EHC1 is controlled by UC8 terminals R/V. Contactor (or solid-state relay) EHC2 is controlled by UC8 terminals SSR2. The fast-acting temperature sensor connects to UC8 input AMB.

Operation using electric heating is as follows:

### **UC8 DIP switch 3 OFF (\*):**

The unit accepts the same control signals as reverse cycle (heatpump) units: COMP and HEAT. A request for cooling (COMP signal on, HEAT signal off) will start the compressor and leave the electric heating element off. A request for heating (COMP and HEAT signals both on) will leave the compressor off and turn the electric heating element on.

### **UC8 DIP switch 3 ON (\*):**

The unit accepts separate control signals for cooling and heating: COOL and HEAT. A request for cooling (COOL signal on, HEAT signal off) will start the compressor and leave the electric heating element off. A request for heating (COOL signal off, HEAT signal on) will leave the compressor off and turn the electric heating element on. The controller will keep the compressor and the electric heating element both off whenever it receives a simultaneous request for both cooling and heating.

### **(\*) Note:**

When the unit is controlled with a temperzone TZT-100 or a SAT-3 room thermostat the setting of UC8 DIP switch 3 is ignored, either setting is acceptable even regardless of the configuration of the thermostat itself.

At all times when the electric heating element is on the indoor fan must be on also. If the thermostat or BMS has requested for the electric heating element to be on the UC8 will automatically also turn on the indoor fan (at low speed as the minimum), even if the thermostat or BMS does not request the indoor fan to run.

When the electric heating element turns off the indoor fan will continue to run for at least another 2 minutes at the low speed setting or faster. The 2-minute indoor fan run-on time is essential to remove all remaining heat from the electric heating element.

## 8. Capacity control for hydronic units with variable speed compressor (inverter)

A unit with a variable speed compressor (inverter) is capable of variable duty. The following chapters provide information on how the UC8 can control capacity of a hydronic unit with inverter.

### 8.1. Capacity control signal

The UC8 offers the following options for control of unit capacity:

- Automatic capacity control when controlled with a SAT-3 or a TZT-100 room thermostat.
- 0-10V analogue control voltage via UC8 input VC.
- Modbus RTU serial communications.
- BACnet/IP serial communications with a Babel Buster gateway module (optional).

### 8.2. Minimum and maximum capacity

	Minimum	Nominal (rated)	Boost (optional)
<b>Capacity</b>	40%	100%	≈125%
<b>UC8 input VC 0-10V control voltage</b>	3.0V	7.5V	10.0V
<b>Serial communications capacity control</b>	30	75	100

Switching on and off of the compressor is not controlled by the capacity signal. A capacity request lower than the minimum (capacity control voltage 0V to 3.0V or a register/object value from 0 to 30) will provide the minimum capacity.

Unless boost capacity is enabled a capacity request higher than nominal (capacity control voltage 7.5V to 10V or a register/object value from 75 to 100) will provide the nominal (unit rated) capacity.

### 8.3. Compressor start-up capacity

During the first 90 seconds after starting the compressor capacity is fixed to 67% of unit rated capacity. After these first 90 seconds normal capacity control is available.

### 8.4. Oil recovery (oil flush) cycles

If an inverter is operated on low capacity for longer than 1 hour and 40 minutes the controller performs an oil recovery cycle. Oil recovery cycles can be necessary to return the lubricating oil to the compressor and last for 1 minute. During this 1 minute capacity is fixed to 80%.

It is possible to change the interval between oil recovery cycles (normally 1 hour and 40 minutes). It is also possible to disable oil recovery cycles. If this is required contact temperzone customer service.

### 8.5. Boost mode

Temperzone units provide rated (nominal) duty and efficiency (EER) with the compressor operating in the range of 65 to 75% of maximum compressor speed. This is referred to as 100% capacity. To run an inverter unit at nominal duty provide a capacity control signal of 7.5V on UC8 input VC or provide value 75 to the capacity control register/object via Modbus RTU or BACnet/IP.

It is possible to operate an inverter unit in boost mode which provides higher than nominal duty.

To enable operation in boost mode hold down UC8 pushbutton SW3 until the display shows a small letter ‘u’, then release the button. The controller enters ‘boost mode configuration’ mode and the display will show the currently selected option. Use the pushbutton to select the desired boost mode configuration number:

Number	Nominal capacity	Additional boost mode capacity allowed	Time limit
0	100%	0% (default setting)	-
1		Up to 5% extra capacity	15 minutes every 3 hours
2		Up to 10% extra capacity	
3		Up to 15% extra capacity	
4		Up to 20% extra capacity	
5		Up to 25% extra capacity	
6	≈ 90%	0%	-
7		Up to 5% extra capacity	15 minutes every 3 hours
8		Up to 10% extra capacity	
9		Up to 15% extra capacity	
10		Up to 20% extra capacity	
11		Up to 25% extra capacity	
12	≈ 75%	0%	-
13		Up to 5% extra capacity	15 minutes every 3 hours
14		Up to 10% extra capacity	
15		Up to 15% extra capacity	
16		Up to 20% extra capacity	
17		Up to 25% extra capacity	
18	Reserved, do not select.		
19	≈ 125%	0%	Unlimited

**Note:**

Operation in boost mode provides higher than nominal rated duty but the following aspects must be carefully taken into account:

- Unit efficiency (EER) will be lower than the unit rated value.
- The unit may produce more audible noise.
- When operating in heating mode the supply water temperature must be warm enough to ensure the water leaving temperature remains well above 0°C.

**Mode 0 (factory default setting):**

A unit configured for mode 0 does not allow any operation in boost mode. A capacity control signal higher than nominal (voltage on input VC 7.5V to 10V or register/object value 75 to 100) will deliver unit nominal rated duty.

**Modes 1 ~ 5:**

A capacity control signal higher than nominal will provide extra capacity as specified in the table above, for up to a maximum duration of 15 minutes. When the unit has been operated in the boost region for 15 minutes then for the next 3 hours the controller will limit capacity to nominal (100%). After the 3 hour period another 15 minutes of boost mode is allowed.

**Example:** Mode 4 allows operation up to a maximum of  $100\% + 20\% = 120\%$  for up to 15 minutes. The control signal to obtain 120% capacity is  $7.5 + 2.0 = 9.5\text{V}$  or register/object value 95.

**Modes 6 ~ 11 and 12 ~ 17:**

These options operate similar to modes 1 to 5 but with the nominal capacity reduced from 100% to:

- approximately 90% (modes 6 to 11)
- approximately 75% (modes 12 to 17)

These modes can be useful in applications where very low compressor noise is required or to reduce the number of outdoor coil de-icing cycles (when the unit is heating).

**Mode 18:**

Reserved, do not select.

**Mode 19:**

Operation at any capacity from minimum to full boost with no time limits. **Use with care!**

## 9. Dry mode (de-humidification)

Temperzone hydronic units with UC8 controller offer three options for cooling mode:

Mode	Indoor fan speed
Standard cooling	Fixed
High-efficiency cooling	Variable
Dry cooling (de-humidification)	Variable

- **Standard cooling mode:**

This is the default mode. In this mode the controller does not actively control the indoor coil temperature. De-humidification occurs only when the indoor coil temperature is below the dew point. Under normal operating conditions the indoor fan speed is kept equal to the speed requested by the thermostat.

Standard cooling mode is suitable for installations where indoor airflow must remain constant and where de-humidification is less important.

- **High efficiency cooling mode:**

The UC8 controller must be allowed to vary the indoor fan speed to obtain an indoor coil temperature for optimum unit duty and efficiency. Note that indoor fan speed can be different from the speed as requested by the thermostat. De-humidification occurs only when the indoor coil temperature is below the dew point.

High efficiency cooling mode may be unsuitable for installations where indoor airflow must remain constant.

- **Dry cooling mode (de-humidification):**

The UC8 controller must be allowed to vary the indoor fan speed to obtain an indoor coil temperature to that is below the dew point. Thus actual indoor fan speed can be different from the speed as requested by the thermostat.

Dry cooling mode may be unsuitable for installations where indoor airflow must remain constant.

### 9.1. Enabling the TZT-100 thermostat for dry mode

**Note:** This option is available only on TZT-100 thermostats with software version 2.31 or later.

To configure the TZT-100 thermostat for dry mode:

- Press-and-hold the O/RIDE button for 15 seconds until the PIN code is shown (88:15).
- Use the Up/Down buttons to select the correct PIN code (default is 88:21), then press O/RIDE again. The thermostat is now in installer mode.
- Press O/RIDE a number of times until the screen shows Fn.
- Press the Up/Down buttons to select the correct option. The options are:
  - -- manually select heating / cooling
  - H heating only
  - C cooling only
  - A heating / cooling / auto
  - **d-** manually select heating / cooling / cooling with **dry mode**
  - **dC** cooling / cooling with **dry mode**
  - **dA** heating only / cooling only / cooling with **dry mode** / auto with **dry mode**
- After selecting the desired option press MODE to exit from installer mode.

### 9.2. Enabling the SAT-3 thermostat for dry mode

Refer to the SAT-3 installer and user manuals.

### 9.3. Enabling dry mode with a communicating BMS

Refer to document “Temperzone UC8 Modbus communications” or “Temperzone UC8 BACnet communications”.

### 9.4. Operating in dry cooling mode

To activate dry mode:

- With TZT-100 thermostat: Select cool + dry or auto cool / heat + dry, start the unit in cooling mode. Select fan setting “Low-Med-High”.
- With SAT-3 thermostat: Select cool + dry or auto cool / heat + dry, start the unit in cooling mode. Select fan auto-speed (the word AUTO shows on the fan display).
- With communicating BMS: Refer to document “Temperzone UC8 Modbus communications” or “Temperzone UC8 BACnet communications”.



## 10. Indoor fan control

The UC8 controller can be configured to control a 1-speed type fan (off/on), a 3-speed fan (off/low/medium/high) or a continuously variable speed fan (EC fan). The following inputs are provided for control of the indoor fan:

- Inputs LO-ME-HI (24V AC or 12V to 24V DC signals, note 1)
- Input VF (0-10V, note 1)
- SAT-3 or TZT-100 room thermostat (note 2)
- Modbus RTU serial communications using RS485 wiring (note 3)
- BACnet/IP serial communications using Ethernet wiring (note 3)

Notes:

1. If the unit is not controlled by serial communication or SAT-3 or TZT-100 then the UC8 automatically selects the input that requests the highest indoor fan speed (LO-ME-HI or VF).
2. If control is by SAT-3 or TZT-100 thermostat the remaining input options are disabled.
3. If serial communications are used then all other control options are disabled. For more information refer to document “Temperzone UC8 Modbus communications” or “Temperzone UC8 BACnet communications”.

Some installations do not permit indoor fan speed to vary from the requested speed at any time. For such installations the indoor fan can be controlled directly by an external controller or the fan may be hardwired to run at a constant fixed speed.

***If the UC8 is not used to control the indoor fan then it is the responsibility of the system- designer and -installer to ensure proper and safe operation of the indoor fan, and the system as a whole, under all operating conditions.***

### 10.1. Variable-speed (EC) indoor fan speed adjustment

The UC8 controls a variable speed indoor fan using a 0-10V signal from output V2. Factory default settings for the output voltage provided on output V2 are:

- Off            0V
- Low            5V
- Medium       6.5V
- High           8V

It is possible to adjust these voltages. If the unit is controlled by a SAT-3 thermostat then placing the SAT-3 in fan speed setup mode will allow adjustment via the keypad on the SAT-3 thermostat. For more information on this refer to the SAT-3 installer manual.

If the unit is not controlled by a SAT-3 thermostat then the fan speed adjustment procedure is as follows:

**To adjust the fan high speed setting:**

Hold down UC8 pushbutton SW3 until the display shows the letter “H”, then release the button. The UC8 will enter “fan high speed setup mode”. The display will show the current high speed voltage setting, e.g. “8.0” and the indoor fan will run accordingly.

Use the pushbutton to change the voltage from 3.0 to 10.0V in steps of 0.5V.

When the desired fan high speed has been set then wait 30 seconds, the controller will save selected setting.

**To adjust the fan low speed setting:**

Hold down UC8 pushbutton SW3 until the display shows the letter “L”, then release the button. The UC8 will enter “fan low speed setup mode”. The display will show the current low speed voltage setting, e.g. “5.0” and the indoor fan will run accordingly.

Use the pushbutton to change the voltage from 1.0 to 8.0V in steps of 0.5V.

When the desired fan low speed has been set then wait 30 seconds, the controller will save selected setting.

**Notes:**

1. If a high speed voltage is selected that is lower than the current setting for low speed, then the low voltage is reduced and becomes equal to the high speed voltage.
2. A similar action happens if one selects a voltage for low speed that is higher than the current setting for high speed: The high speed setting is increased and becomes equal to the low speed voltage.
3. It is allowed to select a low speed voltage equal to the high speed voltage.
4. In cases 1, 2 and 3 as outlined above effectively the fan will then operate as a 1-speed fan at the selected control voltage.
5. Fan medium speed voltage is always halfway between the low and high control voltages.
6. Fan off voltage is always 0V.

In most installations the default values provided by the UC8 will provide an adequate range of indoor airflow whilst avoiding risk of indoor coil frost, water carry-over and excessive noise. Care must be taken when changing the indoor fan speed control voltages:

- To ensure the indoor fan always starts it is recommended to avoid ‘low speed voltage’ settings below 2V.
- To avoid increased risk of frost protection trips and unit lock-out do not set the fan low speed so low that the evaporating temperature can fall below 0°C.
- To avoid risk of water leaking from the supply air vents and corrosion of ducting do not set the fan high speed so high that moisture that may have condensed on the fins of the indoor coil is blown off the coil and into the supply air duct.
- Reducing the high fan speed settings may help when there’s significant noise from supply air vents.
- To reduce risk of ‘over-condensing’ during heating mode, which in turn may cause supply air to feel relatively cool, or even water freeze protection trips, avoid very high fan speed settings.

## 10.2. Translation from 0-10V fan control input signal VF to a fan output signal

Input VF on the UC8 can be used for a 0-10V control signal for the indoor fan. This input can be used for all fan types (1-speed, 3-speed and variable-speed).

### Variable-speed indoor fan controlled via UC8 output V2:

The UC8 does **not** directly copy input voltage VF to output voltage V2, instead the input voltage is **translated** to a corresponding output voltage. The translation ensures that the UC8 programmed fan speed settings are obeyed.

Translation from 0-10V input VF to a voltage on output V2 is as follows, assuming the default settings of 5V to 8V. The hysteresis zone between off and low speed reduces risk of repeated starting and stopping of the fan at low control input voltages.

Input VF	Output V2	Fan
0.0V to 0.99V	0V	Off
1.0V to 1.49V	0 or 5V	Off or Low (hysteresis zone, 0.5V wide)
1.5V to 9.50V	5V to 8V	Low to high
9.5V to 10.0V	8V	High

If above translation is undesirable then one could follow the procedure described in chapter 2 to change the minimum and maximum voltage settings, or one could bypass the UC8 entirely and use an external signal to directly control the indoor fan.

### 3-speed indoor fan controlled via UC8 relays HIGH, MED and LOW:

0-10V input signal VF is converted to Off-Low-Medium-High as per the following table. The hysteresis zones reduce risk of repeated speed changes and “chattering” relays.

Input VF	Fan	‘Width’
0.00V to 0.99V	Off	1.0V
1.00V to 1.49V	Off or Low (hysteresis zone)	0.5V
1.50V to 3.70V	Low	2.2V
3.71V to 4.60V	Low or Medium (hysteresis zone)	0.9V
4.61V to 6.80V	Medium	2.2V
6.81V to 7.70V	Medium or High (hysteresis zone)	0.9V
7.71V to 10.0V	High	2.3V

### 1-speed indoor fan controlled by UC8 relay HIGH:

0-10V Input signal VF is converted to Off-On as per the following table. The hysteresis zone reduces risk of repeated on-off switching and a “chattering” relay.

Input VF	Fan
0.0V to 0.99V	Off
1.0V to 1.49V	Off or On (hysteresis zone)
1.5V to 10.0V	On

## 10.3. Translation from serial communications fan control signal to fan output signal

Refer to document “Temperzone UC8 Modbus communications” or “Temperzone UC8 BACnet communications”.

## 11. Circulating water control signals and protection

### 11.1. Circulating water pump

UC8 output SSR#1 provides a signal that can be used for control of a circulating water pump.

Conditions that activate the water pump output are:

1. When the UC8 receives a request to start the compressor.
2. When the compressor is running.

The signal is activated about 20 seconds prior to the start of the compressor.

If the installation does not require a pump control signal the output can be left unconnected.

### 11.2. Water flow verification switch

UC8 input IN#1 can accept a signal from a circulating water flow verification switch. The switch contacts must be closed-circuit when the water flow is adequate. The UC8 starts checking the signal as soon as it requests the circulating water pump to start via output SSR#1. The switch must activate within 15 seconds or else fault code “no-flow” is reported.

If no flow verification switch is used the input terminals must be connected together (looped).

### 11.3. Water flow control valve

The UC8 provides two output signals that can be used for control of a water flow control valve.

If the water flow control valve accepts a 0-10V control signal then use UC8 0-10V output V1. Control is as follows:

1. When the unit is off the output signal is 0V, the flow valve should close.
2. When the UC8 receives a request to start the compressor the output signal is set to 10V 45 seconds before the compressor is started. This allows even relatively slow-acting valves to open and an adequate flow of water to be present when the compressor is started.
3. When the unit is running in cooling mode UC8 varies the flow valve control signal between 3V and 10V to obtain a condensing temperature of about 40°C.
4. When the unit is heating the control signal is set to 10V.

If the water flow control valve requires an open/close signal (e.g. 230V AC on or off) then use the relay 1 outputs available on the small circuit board with two relays (connected to UC8 output EXV2). Control of an open/close valve is essentially the same as for a 0-10V flow control valve except the valve cannot actively control the condensing temperature when the unit is cooling.

### 11.4. Protection against freezing of the circulating water

A reverse cycle hydronic unit that operates in **heating mode** must be safeguarded from freezing the water in the heat-exchanger. The following measures should be taken:

1. Ensure there is an adequate flow of water through the unit whenever the compressor is running. Use of a water flow verification switch is recommended.
2. Do not allow the water entering temperature to fall below about 10°C.

The UC8 controller continuously monitors temperatures inside the unit. If the controller detects a situation that potentially could lead to freezing of the water the compressor is turned off and an error code is shown on the display. Conditions that activate the freeze-protection function are:

- When the average compressor suction line temperature over the most recent 1 minute has fallen below 0°C. If the unit does not have a temperature sensor fitted to the compressor suction line then the controller monitors the evaporating temperature instead.
- When the evaporating temperature has fallen below -12°C and, at the same time, the compressor suction line temperature has fallen below 0°C.

## 12. Display messages

The LED display on the UC8 circuit board can show the following messages:

Display	Meaning	Notes
<b>UC8 2.1.9</b>	Controller name and software version	Shown only after power-on
<b>dELAY</b>	Random start-up delay time	Up to 30s, occurs only after power-on
<b>•</b>	Ready	Normal operation
<b>–</b>	Unit is OFF by Remote On/Off signal	
<b>t</b>	Test mode	
<b>c</b>	Commissioning mode	
<b>H</b>	Indoor fan high speed selection	Default 8.0V
<b>L</b>	Indoor fan low speed selection	Default 5.0V
<b>A</b>	Modbus address selection	Default 44
<b>E</b>	Compressor model selection	Refer model list in table below
<b>Y</b>	Supply-air temperature control	Default 0 = Off
<b>b</b>	Modbus communications baud rate selection	Default 2 = 19200 baud
<b>P</b>	Modbus communications parity and stop bit selection	Default 2 = even, 1 stop bit
<b>o</b>	Thermostat auto-on/off selection	Default 0 = Off
<b>u</b>	Capacity boost mode limiting selection	Default = 0 (no boost)
<b>HOLd</b>	The compressor is held-on or held-off by a safety timer	
<b>diFF-P</b>	Pressure differential is too high to allow the inverter compressor to start	
<b>dr</b>	DRED energy consumption restriction is active	

The following compressor model & driver combinations can be selected:

Display	Compressor model	Driver (inverter) model
<b>dF</b>	Fixed capacity	None
<b>038</b>	Copeland ZPV 038	Carel Power+ PSD1xx
<b>550</b>	Toshiba DA 550	
<b>66</b>	Siam ANB 66	
<b>78</b>	Siam ANB 78	
<b>87</b>	Siam ANB 87	
<b>063</b>	Copeland ZPV 063	Emerson CSD100 (M600)
<b>010</b>	Inverter compressor and driver controlled via 0-10V signal from UC8 output V2	

The display can be used to monitor pressures and temperatures while the unit is in normal mode or in commissioning mode. This is available regardless whether the compressor is on or off. Repeatedly press the pushbutton to cycle the display through the options (in a round robin fashion). After 2 minutes the display will automatically return to a flashing dot (or ‘c’).

Display	Meaning	Units
● or c	Normal mode (default)	-
SLP	Compressor suction line pressure	kPa
Et	Evaporating temperature	°C
SLt	Compressor suction line temperature	°C
SSH	Compressor suction side superheat	K
dLP	Compressor discharge line pressure	kPa
Ct	Condensing temperature	°C
dLt	Compressor discharge line temperature	°C
dSH	Compressor discharge side superheat	K
ICEt	Supply-water temperature (if sensor is fitted on water-in pipe)	°C
CAP	Unit capacity (duty)	%
EE1	Electronic expansion valve 1 opening	%
EE2	- (no function on hydronic units)	%
Add	UC8 Modbus RTU slave address	-
● or c	Back to button press 0	-

Pressures are shown in kPa. Divide by 6.895 (roughly 7) to convert to PSI.

Temperatures are shown in whole degrees Celsius. If the indicated temperature is below 0°C then a minus sign is shown before the value. If the unit has one or two pressure transducers then the condensing and/or evaporating temperatures shown can be converted from pressure readings.

If a reading is not available then the display shows a dash symbol (-).

### 13. Troubleshooting

When the UC8 controller detects a problem within the system the fault relay output (FLT) is activated. Fault light FLT will illuminate and a fault code is shown on the LED display.

Some faults will stop the compressor and the fan. Other faults may stop the compressor but allow the fan to continue running. Yet other faults will be signalled but do not stop the unit from operating.

If a serious fault repeatedly stops the unit it may be locked-out. A locked unit will not run the compressor and the fan. To unlock the unit cycle mains power to the unit off and on again, alternatively a unit can be unlocked via Modbus RTU or BACnet serial communications.

If a unit locks out three times successively without completing a successful cooling or heating cycle then the unit will be locked out and can only be unlocked by pressing the UC8 pushbutton.

Chapter 0 lists the fault codes.

Document “**Temperzone UC8 troubleshooting guide**” provides more detailed information on the fault codes, possible causes and remedies.

**13.1. Fault codes**

Display	Meaning
LP	Low pressure protection is active
HP	High pressure protection is active
OL	Overload protection (input IN#2 is open circuit)
FROSt	Indoor coil frost protection is active
HI-t	High temperature protection is active
HI-SL	High suction line temperature protection is active
Lo-dSH	Low discharge superheat protection active
Hi-dSH	High discharge superheat protection active
CRL	Low compression ratio protection
CRH	High compression ratio protection
FREEZE	Water freeze protection is active
Lockout	Unit is locked out, to unlock the pushbutton must be pressed

Display	Meaning
F10	Outdoor fan fault
F11	Indoor fan fault
F12	Low pressure transducer fault
F13	High pressure transducer fault
F14	Suction line temperature sensor fault
F15	Discharge line temperature sensor fault
F16	De-Ice temperature sensor fault
F17	Outdoor coil temperature sensor fault
F18	Indoor coil temperature sensor fault
F19	Ambient temperature sensor fault
F20	Superheat is unknown
F21	Thermostat fault (no serial communications)
F22	BMS fault (no serial communications)
F26	Invalid DIP switches setting
F27	Invalid fan selection
F28	Illegal operating mode requested
F29	Microcontroller temperature exceeds +100 °C
F30	Supply voltage out of bounds (+3.3V DC supply voltage on controller PCB)
F32	0-10V input fault

Continued on the next page.

Fault codes, continued.

Display	Meaning
F33	High discharge superheat protection active
F34	Problem with pressure transducer readings or pressures not equalising
F35	Reverse cycle valve fault
F36	Invalid DIP switch setting on TZT-100 thermostat
F39	Variable speed compressor driver reports a fault
F42	Evaporating temperature too high
F43	Condensing temperature too low
F44	Invalid EEV mode selection

The following sets of fault codes apply only to units with a variable speed compressor.

**For the Carel Power+ driver:**

The fault code shown is F100 plus the error code reported by the Power+ driver. For detailed information about the Power+ fault codes refer to the **Carel Power+ speed drive user manual, chapter 8.3: Alarms table**. A brief summary follows here:

Display	Meaning
F100	No communications between Power+ driver and UC8
F101	Motor over-current
F102	Motor overload
F103	Over-voltage
F104	Under-voltage
F105	Drive too hot
F106	Drive too cold
F107	Drive over-current
F108	Motor too hot
F109	Reserved
F110	Drive internal error
F111	Incorrect parameter
F112	Excessive drive DC bus ripple (unbalanced mains phase voltages)
F113	Communication fault
F114	Internal fault
F115	Auto-tuning fault
F116	Driver is disabled (input STO is open circuit)
F117	Motor phase fault (possibly a motor wire has become loose)
F118	Internal fan fault
F119	Speed fault
F120	Power factor correction circuit overload
F121	Mains input voltage too high
F122	Mains input voltage too low
F123	Drive internal fault
F124	Reserved

Continued on the next page.



Power+ alarm codes, continued.

<b>Display</b>	<b>Meaning</b>
F125	High earth current fault
F126	Drive processor overload
F127	Drive memory loss
F128	Drive overload protection
F197	Drive reports incorrect compressor speed
F198	Drive and compressor mismatch
F199	Drive configuration fault

## 14. Specifications

**Notes:**

- Relay outputs HIGH, MED, LOW, C3, C4, CMC, R/V, SSR#1 and SSR#2 are isolated from all other circuits. It is permitted to connect these relay outputs to mains live circuits.
- Inputs HI, ME, LO, C1, CP, HT and C2 are isolated from all other circuits. These inputs accept 24V AC or 12V DC control signals.
- All other input and output signals from/to the UC8 are referenced to unit EARTH.
- It is recommended that any input signal that is referenced to EARTH and that needs to connect to a circuit external to the temperzone unit to be isolated by a suitable means, for example a relay. Typical examples of this are the remote On/Off input and the DRED inputs.
- **For safety and to ensure correct operation of the unit the EARTH terminal must directly connect to a unit earth stud located close to the controller board.**

<b>Controller environmental conditions</b> Storage temperature range Operating temperature range Relative humidity	-20 to +75°C -10 to +65°C 20 to 95% non-condensing		
<b>Mains input</b> L and N	230V AC 50Hz nominal	190V AC minimum	250V AC maximum
<b>Output relays</b> Applies to: HIGH, MED, LOW, CMC and R/V outputs	250V AC, 5A maximum, resistive load 250V AC, 2.5A maximum, inductive load		
<b>Solid state output relays</b> Applies to: SSR1 and SSR2 outputs	12V AC minimum, 250V AC maximum ( <b>AC only!</b> ) 0.25A maximum (continuous) 2.5A maximum (peak, 0.5s)		
<b>AUX and FLT outputs</b> Designed to operate a relay with 12V DC coil.	Open collector and +12VDC output OFF state: leakage current 0.5mA maximum ON state: 12V DC, 100mA maximum		
<b>EXV1 output</b> For control of auni-polar electronic expansion valve (5-wire or 6-wire type)	Open collector and +12VDC output OFF state: leakage current 0.5mA maximum ON state: 12V DC, 275mA maximum per winding/coil		
<b>EXV2 output</b> For control of 12V DC relay coils.	Open collector and +12VDC output OFF state: leakage current 0.5mA maximum ON state: 12V DC, 275mA maximum per winding/coil		

Continued on the next page.

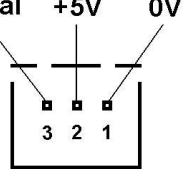
<b>Isolated inputs</b> Applies to: HI, ME, LO, CP and HT inputs Common terminals are: C1 for HI, ME and LO C2 for CP and HT	<b>When used with 24V AC input signals:</b> Maximum input voltage OFF state: 2V RMS AC Minimum input voltage ON state: 18V RMS AC Absolute maximum input voltage: 35V RMS AC Input impedance: 2.5kΩ
	<b>When used with 12V DC input signals:</b> Maximum input voltage OFF state: 2V DC Minimum input voltage ON state: 11V DC Absolute maximum input voltage: 35V DC Input impedance: 2.5kΩ
<b>VC and VF 0-10V analogue inputs</b> Referenced to terminal 0V	Absolute maximum input voltage: -2 to +15V DC Nominal input voltage: 0 to +10V DC Input impedance: 13.9kΩ
<b>IN#1 and IN#2</b> <b>DRED inputs D1, D2, D3</b> <b>Remote On/Off input</b> Referenced to terminals 0V and SC	Designed to be operated by isolated voltage free contacts. Open circuit voltage: 3.3V DC typical Closed circuit current: 3.3mA DC typical
<b>V1 and V2 0-10V analogue outputs</b> Referenced to terminal 0V	Maximum load: 6.5kΩ Maximum short circuit output current: 30mA
<b>Temperature sensor inputs</b> DL: red SL: white AMB: black (electric heating models only) IC: yellow OC, DEI: not used on hydronic units	Designed to connect to standard Temperzone thermistor temperature sensors.
<b>Pressure transducer inputs</b> signal +5V 0V 	Power: 5.0±0.2V DC, maximum current draw 50mA Signal: 0.5V at the lowest pressure 4.5V at the highest pressure Pressure ranges: LPT, all units: 0 to 3450 kPa (0-34.5 bar, 0-500 PSI) HPT, all units: 0 to 4500 kPa (0-45.0 bar, 0-653 PSI)
<b>Modbus RS485 serial communications format</b>	Baud rate 19200 Data bits 8 Parity even Stop bits 1

**Disclaimer:**

Information given in this document is believed to be correct at the time of writing. Temperzone assumes no responsibility for any errors that may appear in this document. Information in this document is subject to change without notice and should not be construed as a commitment by Temperzone. In no event shall Temperzone be liable for incidental or consequential damages arising from use of this document or the software and hardware described in this document.