

# IMD 420Y, 550Y (c/w EC motor)

## Ducted Fan Coil Units

## Installation & Maintenance

### Dimensions (mm)

Not to Scale

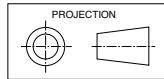

MODEL	CORNER LOADS (kg)			
	W	X	Y	Z
IMD 420Y	35	42	38	30
IMD 550Y	42	47	37	40

**Net Weight**  
(excluding water)  
IMD 420Y 145 kg  
IMD 550Y 166 kg

Fig. 1

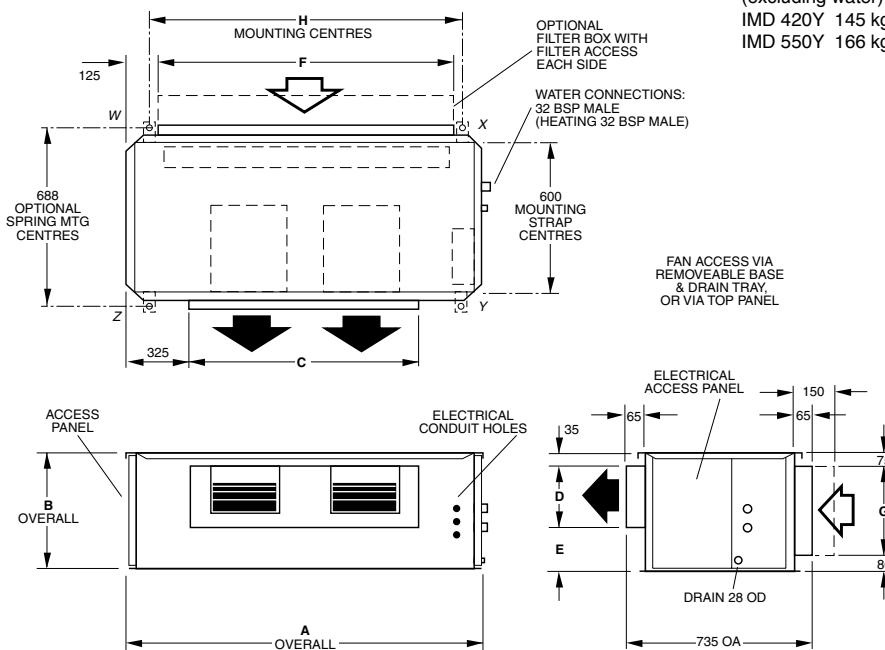

MODEL	A	B	C	D	E	F	G	H
IMD 420	1625	575	975	300	240	1375	425	1518
IMD 550	1680	700	1030	310	355	1430	555	1573

**Note:** The manufacturer reserves the right to change specifications at any time without notice or obligation. Certified dimensions available on request.

### GENERAL

The IMD ducted fan coil units must be installed in accordance with all national and local safety codes.

### Options

1. Filter Box
2. Spring Mounting Kit

### FILTER BOX (Option)

The Filter Box is installed by unscrewing the return air spigot and replacing it with the Filter Box's filter-integrated spigot. The filter may be accessed from either side of this spigot. This new spigot has a depth of 150 mm, instead of 65 mm.

### INSTALLATION

#### Positioning & Mounting

Provide 500 mm minimum clearance to both ends of the unit. If the filter box option is to be used, allow adequate clearance for the filter to be withdrawn to its full length.

If low noise is a critical factor in the installation, refer to Figure 5 for noise isolation recommendations.

It is recommended that the unit be mounted using the spring mounting system, supplied as an optional extra (Fig.2). This system minimises transfer of vibration into the building structure.

If a more rigid installation can be tolerated, then suspend the unit using the four straps supplied, as shown in Figure 3.

Alternatively, holes are supplied in the mounting flange for the use of threaded mounting rods (not supplied).

The unit has a built-in sloping drain tray, therefore mount it level.

### Condensate Drain

The condensate drain should be trapped outside the unit cabinet. The trap should have a vertical height of at least 50 mm. The drain should have a slope of at least 1 in 50 and must not be piped to a level above the unit drain tray. (Refer Fig.4).

For long condensate pipe runs, fit a vent pipe near the drain trap. The top of the vent pipe must be at least 100 mm above the IMD unit's drain tray.

It is essential that the drainage system is checked by pouring water in the drain tray and seeing that it discharges at the end of the drain and does not overflow the drain tray.

**Note:** The built-in drain tray can be removed for cleaning (or fan access) by first removing the unit's base.

Fig. 2 Spring Mounting

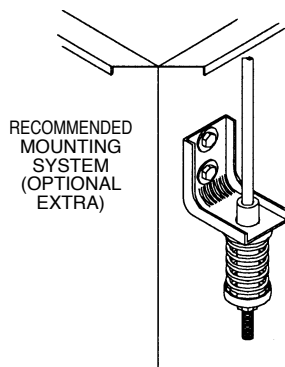
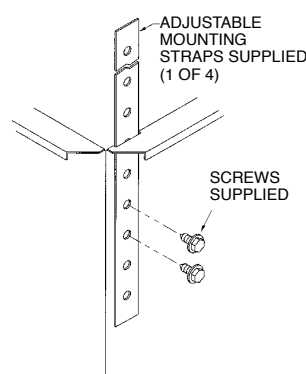

Fig. 3 Strap Mounting



## ELECTRICAL WIRING

The electrical supply required (including voltage fluctuation limits) is:  
1 phase 200-252 V a.c. 50 Hz with neutral and earth. The supply to have an isolation switch adjacent to the unit but not attached to the unit. Recommended external fuse size is 16 amp H.R.C.

Electrical work must be carried out by a qualified electrician in accordance with local supply authority regulations and the wiring diagram.

## FAN SPEED

The fan can be switched ON by selecting High, Medium or Low fan speed on the terminal block, or via BMS. This can be done without starting the compressor.

The fan speed can be 'Stepped' or 'Continuously Variable'. Dip switches 1 to 5 on the Analogue Level Controller (ALC) determine the minimum and maximum fan speeds. The same 'Minimum rpm' and 'Maximum rpm' settings apply to 'Stepped' and 'Continuously Variable'.

The default settings for max. fan speed and fan speed range are highlighted on the Wiring Schematic.

### 1. Stepped (3 Speed)

Connecting the COM power terminal to one (and only one at a time) of the LOW, MED or HIGH speed terminals sets a single fan speed. Connecting the COM power terminal through a 3 speed switch (not supplied) will allow manual speed selection.

LOW will select the minimum rpm, HIGH will select the maximum rpm, MED will select mid-way between the two speeds. The speeds' separation depends on the setting of Analogue Level Controller (ALC) dip switches 4 & 5. The transitions between speeds are smooth.

### 2. Continuously Variable (0-10V Control)

This option is active when 0.5V or more is input to the ALC Controller's 0-10V input terminal.

A voltage below 1.6V DC applied across the '0V' and the '0-10V' input terminals will stop the indoor fan. A control voltage of 2V or more will cause the fan to run at the 'Min. rpm' speed. The 'Min. rpm' depends on the setting of Analogue Level Controller (ALC) dip switches 4 & 5.

A 10V DC signal will run the fan at the 'Max. rpm' speed. Control voltages between these two limits can be used to achieve any desired speed between 'Min.' and 'Max.' rpm.

If the air returning to the indoor unit is regularly expected to be above 50%RH, then the coil face velocity should be limited to be 2.8 m/s or less (refer Air Handling graph in Technical Data pamphlet).

High humidity levels can occur in tropical or subtropical conditions, and/or when heavily moisture laden fresh air is introduced. Select a fan speed that avoids water carry-over problems.

Fig. 4

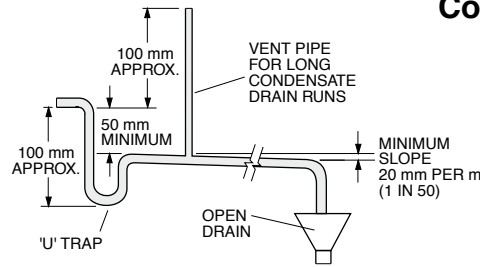

## Condensate Drain

## COMMISSIONING

1. Check that the thermostat is correctly wired and set at the desired temperature.
2. Check that the air filter (if fitted) is clean.
3. Check that the fan runs freely without vibration.
4. Check condensate drain for free drainage.

## MAINTENANCE

### Weekly For First Four Weeks

1. Check air filter (if fitted); vacuum clean as necessary.
2. Check condensate drain for free drainage.

### Monthly

Check air filter (if fitted); vacuum clean as necessary.

### Six Monthly

1. Check condensate drain for free drainage.
2. Check heat exchanger coil; vacuum or brush clean as necessary.
3. Check the tightness of the fan.
4. Check that fan motor is free running.
5. Check tightness of electrical connections.
6. Check air supply at diffuser outlets.

## NOTE

The manufacturer reserves the right to change specifications at any time without notice or obligation. Certified dimensions available on request.

This pamphlet replaces the previous issue no. 3831 dated 08/15.  
Wiring revision E.

## Fig. 5 Application Considerations

### Recommendations for Noise Isolation - particularly for high static installations:

1. Avoid installing units, with non-ducted return air, directly above spaces where noise is critical.
2. Use flexible connections between unit and rigid ducting.
3. Use generously sized acoustically lined ducts.
4. If generous duct size is not possible, use turning vanes on bends to reduce air turbulence (regenerated noise).
5. Use 90° bends in ducting to significantly assist in noise reduction.

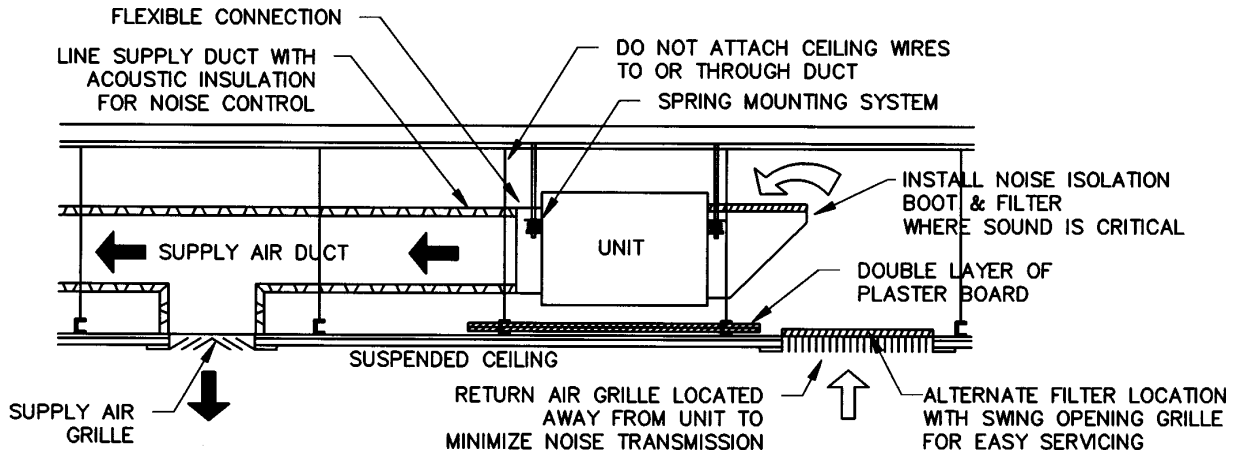
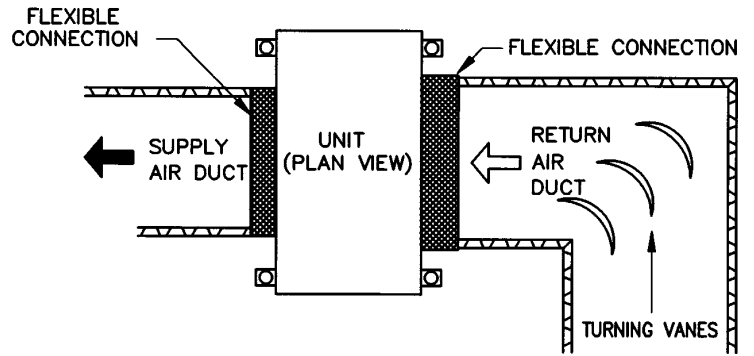

**DIP SWITCH SETTINGS**

DO NOT USE ANY OTHER DIP SWITCH COMBINATIONS EXCEPT THOSE SHOWN IN THE TABLE BELOW.  
 SHADED AREA = DEFAULT SETTINGS

Indoor Fan Speed ALC DIP s/w settings	
DIP Switch	Max Fan RPM
1 2 3	1250
0 0 0	1000
1 0 0	1100
0 1 0	1200
1 1 0	1250
0 0 1	1300
1 0 1	1350
0 1 1	1400
1 1 1	1500

DIP Switch	Speed Range RPM
4 5	300
0 0	450
1 0	600
0 1	900

DIP Switch	Run On (sec)
6	40 Standard
1	120 Elec. Heat

DIP Switch 7 & 8 - OFF -

ABOVE SPEED SETTING SETS THE MAX. SPEED/VOLTAGE (HIGH) THE SPEED RANGE SETS THE DIFFERENCE BETWEEN THE MAX. SPEED AND MIN. SPEED/VOLTAGE(LOW) WITH 3 SPEED CONTROL THE MEDIUM SPEED IS ALWAYS HALFWAY BETWEEN HIGH AND LOW.

**NOTE:**  
 1) DO NOT CONNECT BOTH 3 SPEED L/M/H SWITCH AND ALSO BMS 0-10V (DC) SIGNAL. ONLY ONE CONTROL METHOD MAY BE CONNECTED AT A TIME. IF IN DOUBT ASK!

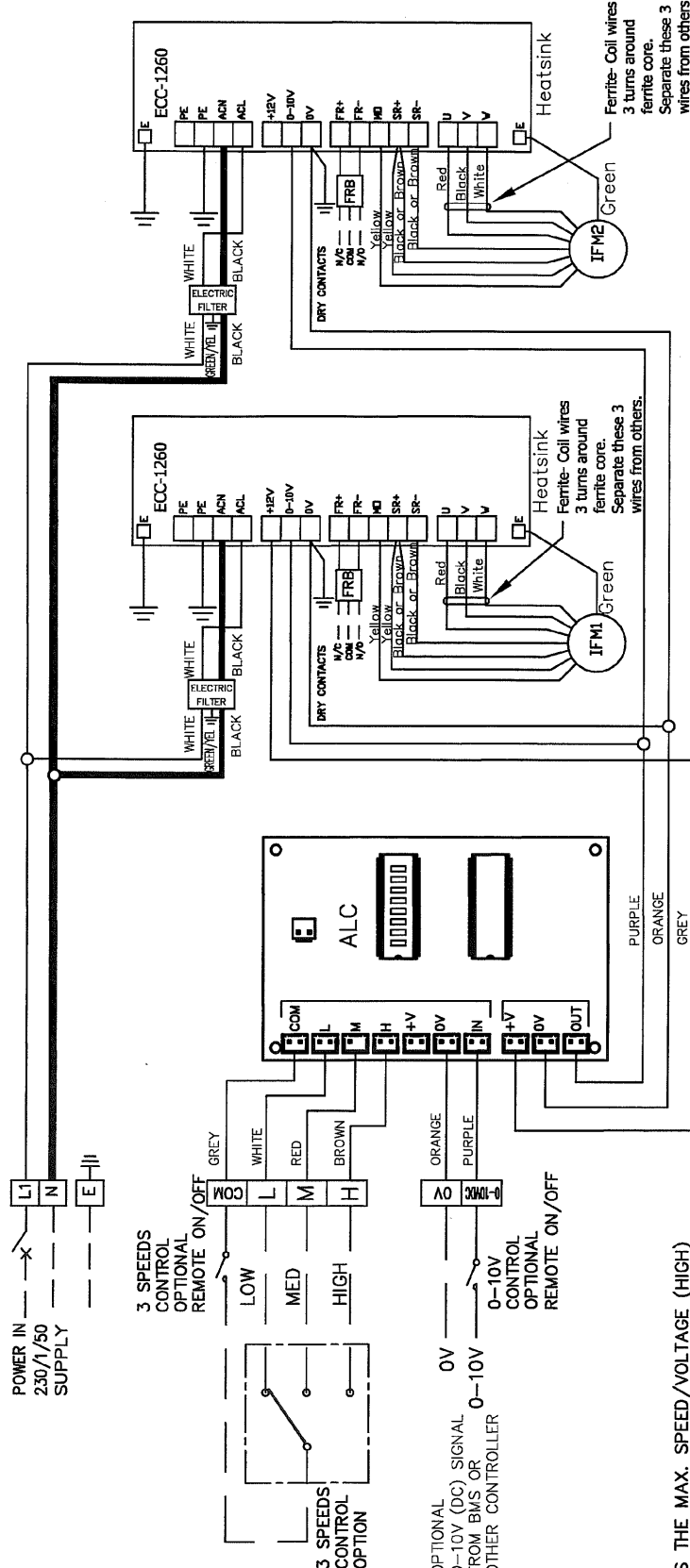

**temperzone**

Title **IMD420Y 550Y WIRING SCHEMATIC**

Drawn **K.L.E** Date **12-02-15** Drawing No. **291-000-103** Revision **E**

Scale **Aprvd. *[Signature]***

ALC	ANALOGUE LEVEL CONTROLLER.
IFM	INDOOR FAN MOTOR
FRB	FAULT RELAY BOARD
---	CLIENT WIRING

MODEL	IMD	420Y, 550Y
VOLTAGE IN	V	230/240
ECC 1260 DRIVER AMPS (MAX)		9A/MTR

ECN	DATE	APRVD
E	20-15	W.A.S
D	20-15	W.A.S
C	14-05	K.L.E
A	14-05	S.S.W

ISSUE MODIFICATION