

## OPA 340RKTBH-Z (c/w Economiser)

# Packaged Reverse Cycle R410A Air Cooled Air Conditioner

# Installation & Maintenance

### GENERAL

This OPA 340RKTBH-Z unit must be installed in accordance with all national and local safety codes.

### Supplied Separately

1. Economiser Fresh Air Cowl.
2. Economiser electronic control system (supplied by others; alternatively factory fitted by temperzone).

### REFRIGERATION SYSTEM

#### General

The OPA 340 has two independent refrigeration circuits and two compressors to provide the flexibility and economy of two stage operation, i.e. utilising one or two circuits as conditions vary, plus the advantage of staggered starting.

Each refrigeration system has been charged with HFC-410A (R410A) refrigerant; refer wiring diagram specification table for amount. Tapping points are provided to measure discharge and suction operating pressures.

#### Compressors

The compressors are directional scroll type. The compressor lubricant is polyol ester oil (POE). Note, this oil absorbs moisture quickly if exposed to open air. On commissioning, the compressors must be checked for correct rotation (refer Start Up Procedure). A delay 'on make' timer prevents simultaneous starting of the compressors.

### ECONOMISER

This OPA 340RKTBH-Z unit is equipped with an Economiser. The purpose of the Economiser is to allow the introduction of low ambient outside air into the air conditioner during the cooling cycle, thereby lowering operating costs.

A fresh air and return air damper is supplied built-in to the sides of the OPA 340RKTBH-Z unit.

**Note:** This unit is not supplied with an electronic control system to operate the Economiser – unless it was requested as a factory fitted option. It is recommended that the economiser dampers' control is by enthalpy or wet bulb temperature sensing – not by dry bulb temperature control.

If the outdoor air temperature or heat content preferably, is below that of the return air the fresh air damper should open and the return air damper close to provide the first stage of cooling. A spill air facility in the building may be necessary for when

the return air damper is closed. The fresh air damper should return to minimum setting and the return air damper open before compressors are allowed to operate to provide further cooling. A low limit thermostat is fitted to prevent compressors operating with a mixed air-on coil temperature below 18°C; resets at 20°C. This is by-passed during heating mode.

### INSTALLATION

#### Positioning

Refer to dimension diagrams for minimum clearances. If multiple units are to be placed side-by-side then allow at least 2 m between coil faces.

#### Mounting

The unit should be fastened to a firm flat horizontal base using the holes supplied in the mounting channels.

When the unit is being installed on a roof it is recommended that the unit is installed on a substantial structure with vibration isolating mounts or pads beneath the unit. Two channels are provided under the base for spring mounting or bolting down.

Flexible duct connections are recommended between the supply and return ducts and the unit.

Refer separate instructions for installation of the Economiser Fresh Air Cowl.

#### Drains

Both the condensate drain and the fresh air cowl rainwater drain should be 'U' trapped outside the unit. The trap should have a Downward height of at least 100 mm. The drain should have a slope of at least 1 in 50 and must not be piped to a level above the unit drain pipe (see figure 2).

#### Electrical Requirements

Electrical work must be done by a qualified electrician. The outdoor unit must be wired directly from a distribution board by means of a circuit breaker and a mains isolator provided - preferably close to the unit.

**Note:** DO NOT USE REWIRABLE FUSES.

The OPA 340 is provided with a 24V AC control circuit for a thermostat, on/off switch and/or time clock.

Standard units are suitable for use with thermostats with either manual Heat/Cool selection or automatic changeover subject to the contact ratings of the thermostats.

A 24 hour power supply to the compressor crank case heaters is required, otherwise the warranty is void.

Economiser wiring varies depending on which electronic control system is used, however the main terminal connections to control the Fresh Air Damper are shown in the wiring diagram.

### CHECK TESTS

1. Check that the compressor is secure on its mounts.
2. Check by hand that all fan motors can turn freely.
3. Check that the air filters have been correctly installed, if fitted.
4. Check air diffuser dampers are open if appropriate.
5. Check that the thermostat, or external 24V controller, is correctly wired to the unit and is set at the desired temperature.
6. Check the tightness of all electrical connections.
7. Leave the thermostat, or external 24V controller, in the off position and close the mains isolating switch. (A four hour delay period is required to allow the crankcase heater to drive any liquid refrigerant out of the compressor oil.)
8. Check the supply voltage between each phase and neutral.

### START UP PROCEDURE

After the four hour delay for the crankcase heater has expired, use the supplied Commissioning Sheet (Form NS 217) to record results when completing the following 'Start-up' procedure. Ideally a UC6 Service Interface and associated communication cable (temperzone part no.s 201-000-379 and 201-000-378) should be used to read, pressures, superheat and its set-point, compressor amps etc.

1. Select a sensible Fan speed (or Auto Fan mode), operating cycle (cool or heat), and room temperature set point, depending on the time of year, such that the compressor will start and run at a high capacity.
2. Turn ON the thermostat / external controller. Wait for the compressor to start. Measure the current for each phase feeding into the compressor's. Compare against the compressor amps specified on the unit's wiring diagram.
3. Compressors fitted are directional. Check for correct rotation. If rotation is incorrect the compressor will not pump, be noisy, and will draw minimal current. To correct motor rotation, change the phasing at the main power terminal. If changing the phasing, check the indoor air fan then runs in the correct direction also.

4. Measure the current draw of each fan motor. Check all readings against the specified values in the wiring diagram.
5. If a UC6 Service Interface is available, operating pressures and status can be read from its various display screens. If a UC6 Service Interface is not available, fit gauges and measure the suction and discharge pressures of both refrigeration circuits.
6. Check that the outdoor air fan motors are running smoothly and drawing less than the full load amps specified.
7. Check the indoor unit's fan belt tension after 20 mins of operation and adjust if necessary (refer Commissioning Sheet).
8. Test the operation of the reversing valve by running the unit in both the heating and cooling mode.
9. Check the supply air flow at each outlet.
10. Touch up any outdoor unit paintwork damage to prevent corrosion.

#### SETTING SUPPLY AIR FLOW

Consult OPA 340 Technical Data pamphlet at [www.temperzone.biz](http://www.temperzone.biz) for details of airflow/duct static pressure, if required.

If the indoor air returning to the unit is regularly expected to be above 50%RH, then the coil face velocity should be limited to be 2.5 m/s or less (refer Air Handling graph in Technical Data pamphlet).

High humidity levels can occur in tropical or subtropical conditions, and/or when heavily moisture laden fresh air is introduced. Select a fan speed that avoids water carry-over problems.

In a free blow or low resistance application, beware of exceeding the fan motor's full load amp limit (refer wiring diagram).

The indoor air fan motor is fitted with a factory set adjustable pitch pulley. Instructions for the adjustment of pulleys is included on the back page of the supplied Commissioning Sheet. One revolution of adjustment is equal to approx. 7% change in air volume flow rate.

Air flow through the damper should not exceed 15% of the OPA unit's nominal air flow when the OPA unit's refrigeration system is operating.

Note: Excessive amounts of low ambient fresh air will reduce the performance of a reverse cycle OPA unit on heating cycle.

Set the economiser Fresh Air Damper motor 'stop' to the equivalent negative static pressure as with F/A damper closed. This is to ensure the air flow volume remains constant and does not dramatically increase when introducing fresh air. Failure to set the correct 'stop' position could result in rain/moisture entrainment in the incoming fresh air resulting in water deposited inside the unit.

#### UNIT CONTROLLER (UC6)

The Unit Controller provides system protection functions such as coil frost protection, de-icing, high head pressure and low suction pressure cut-out.

It also protects against rapid cycling of the compressor(s) and loss of refrigerant. Various methods of head pressure control (or limiting) are employed in temperzone units. The particular method used varies from model to model, but is also handled by the Unit Controller. In combination, these features deliver optimised performance across a wide operating temperature range.

Refer to UC6 Controller label on the unit for operation & fault diagnostics information. Many operating status conditions can be determined, without gauges, simply by using a *UC6 Service Interface* graphical display available from **temperzone**.

#### MAINTENANCE

##### Monthly

1. Check air filters, if fitted, and vacuum or wash clean as necessary.
2. Check condensate drain and Fresh Air Cowl rainwater drain for free drainage.
3. Check compressor compartment for oil stains indicating refrigerant leaks.

##### Three Monthly (or every 1200 hrs of operation)

Check the indoor unit's fan belt tension and adjust if necessary.

##### Six Monthly

1. Check the tightness of electrical connections.
2. Check the tightness of fans, motor mountings, pulleys and belt tension.
3. Check suction and discharge operating pressures. (Using a UC6 Service Interface avoids fitting and removing gauges with consequential refrigerant loss.)
4. Replace indoor air filters (if fitted).
5. Check condensate drain for free drainage.

##### Yearly

1. Check all refrigerant piping for chafing and vibration.
2. Check the operation of electric heaters, if fitted.
3. Check air supply at all diffusers.
4. Check for excessive noise and vibration and correct as necessary.
5. Check for insulation and duct damage and repair as necessary.
6. Remove lint and dust accumulation from outdoor coil fins.
7. Touch up any paintwork damage to prevent corrosion.

#### NOTE

The manufacturer reserves the right to make changes in specifications at any time without notice or obligation. Certified data is available on request.

This pamphlet replaces the previous issue no. 3851 dated 07/17. Shipping block reference removed.

# DIMENSIONS (mm)

# OPA 340RKTB

## Fig. 1 OPA 340RKTBH – Horizontal Supply & Return Air

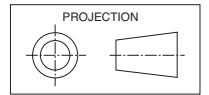

Not to Scale

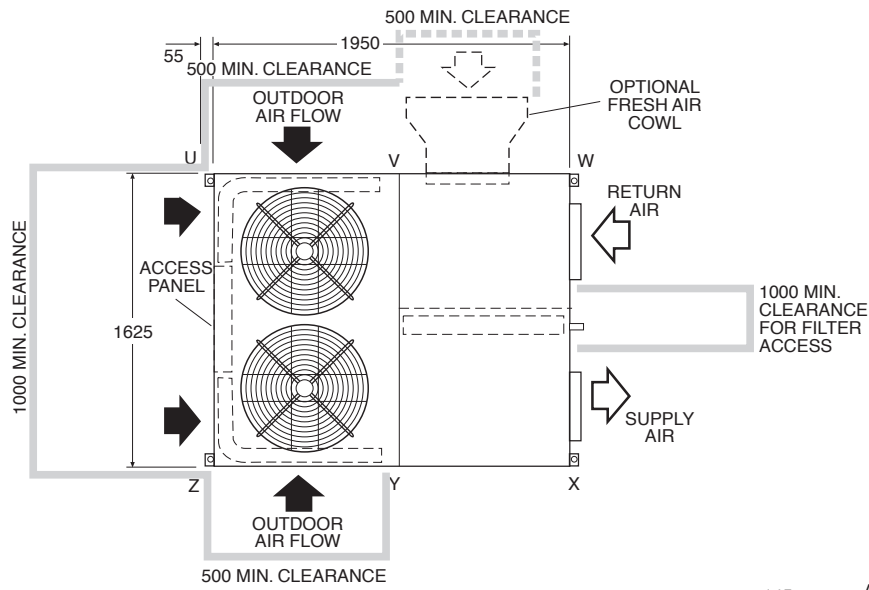

POINT LOADS (kg)					
U	V	W	X	Y	Z
110	96	82	106	115	122

Net Weight 631 kg

**Note :** A 2 m clearance is required above the exhaust air fans

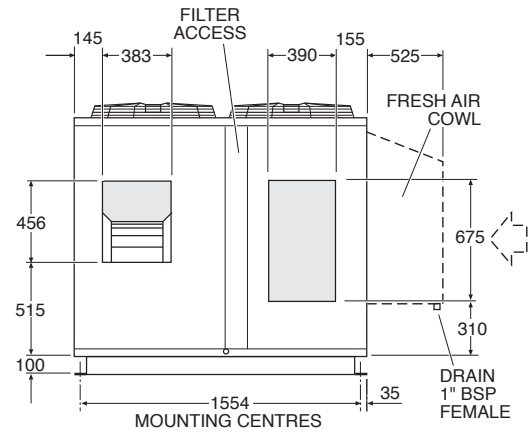
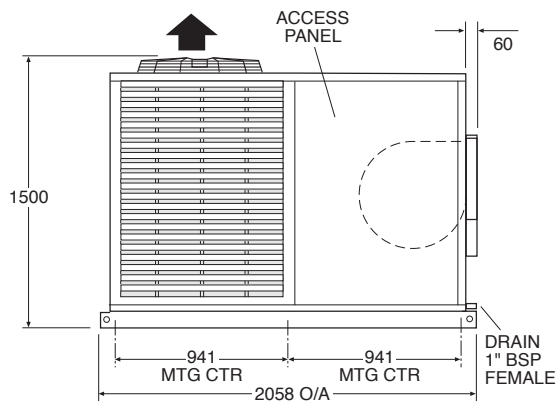

## Fig. 2 Condensate/Fresh Air Cowl Drains

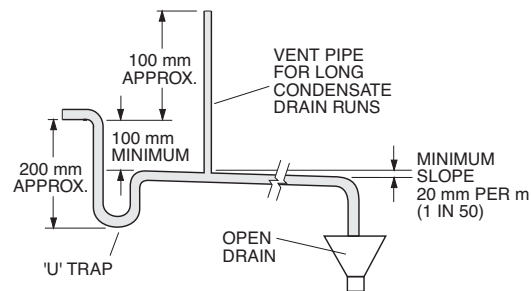

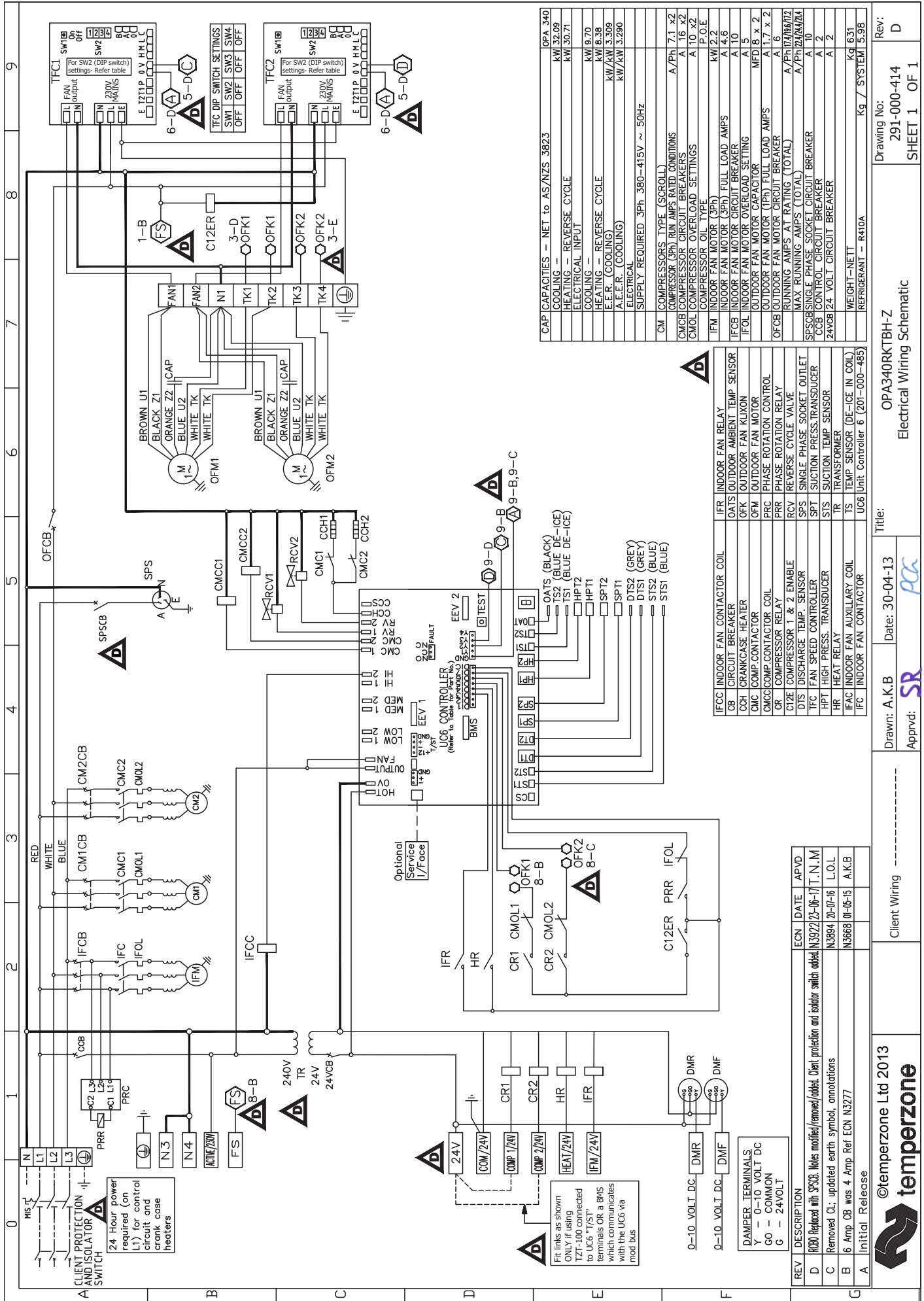

REV	DESCRIPTION	ECN	DATE	APVD
D	Revised with SPS3. Notes modified/removed/added. Client protection and isolator switch added. N3927/23-06-17/T.N.M	N3927	23-06-17	T.N.M
C	Removed CL; updated earth symbol, annotations	N3904	20-07-16	L.O.L
B	6 Amp CB was 4 Amp Ref ECN N3277	N3668	01-05-15	A.K.B
A	Initial Release			

REV	DESCRIPTION	ECN	DATE	APVD
D	Revised with SPS3. Notes modified/removed/added. Client protection and isolator switch added. N3927/23-06-17/T.N.M	N3927	23-06-17	T.N.M
C	Removed CL; updated earth symbol, annotations	N3904	20-07-16	L.O.L
B	6 Amp CB was 4 Amp Ref ECN N3277	N3668	01-05-15	A.K.B
A	Initial Release			

REV	DESCRIPTION	ECN	DATE	APVD
D	Revised with SPS3. Notes modified/removed/added. Client protection and isolator switch added. N3927/23-06-17/T.N.M	N3927	23-06-17	T.N.M
C	Removed CL; updated earth symbol, annotations	N3904	20-07-16	L.O.L
B	6 Amp CB was 4 Amp Ref ECN N3277	N3668	01-05-15	A.K.B
A	Initial Release			

Drawing No: OPA340RKTBH-Z  
 Rev: D  
 Title: Electrical Wiring Schematic  
 Date: 30-04-13  
 Drawn: A.K.B  
 Approved: SR  
 Client Wiring  
 ©temperzone Ltd 2013  
**temperzone**