

OPA 2000RKTMO1

Packaged Reverse Cycle R410A Air Cooled Air Conditioner

Installation & Maintenance

GENERAL

This OPA 2000RKTMO Outdoor Unit must be installed in accordance with all national and local safety codes.

REFRIGERATION SYSTEM

General

The OPA 2000 has four independent refrigeration circuits and four compressors to provide the flexibility and economy of four stage operation, i.e. utilising one or more circuits as conditions vary, plus the advantage of staggered starting.

Each refrigeration system has been charged with HFC-410A (R410A) refrigerant; refer wiring diagram specification table for amount. Tapping points are provided to measure discharge and suction operating pressures.

Compressors

The compressors are directional scroll type. The compressor lubricant is polyol ester oil (POE). Note, this oil absorbs moisture quickly if exposed to open air. On commissioning, the compressors must be checked for correct rotation (refer Start Up Procedure). A time delay prevents simultaneous starting of the compressors.

ECONOMISER (Option)

If the outdoor air temperature or heat content preferably, is below that of the return air the fresh air damper opens and the return air damper closes to provide the first stage of cooling. A spill air facility in the building may be necessary for when the return air damper is closed. The fresh air damper should return to minimum setting and the return air damper open before compressors are allowed to operate to provide further cooling.

INSTALLATION

Positioning

Refer to dimension diagrams for minimum clearances. If multiple units are to be placed side-by-side then allow at least 2 m between coil faces.

Mounting

The unit should be fastened to a firm flat horizontal base using the holes supplied in the mounting channels.

When the unit is being installed on a roof it is recommended that the unit is installed on a substantial structure with vibration isolating mounts or pads beneath the unit.

Flexible duct connections are recommended between the supply and return ducts and the unit.

Condensate Drain

The condensate drain should be 'U' trapped outside the unit. The trap should have a vertical height of at least 100 mm. The drain should have a slope of at least 1 in 50 and must not be piped to a level above the unit drain pipe.

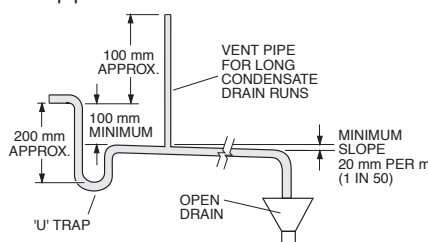

Electrical Requirements

Electrical work must be done by a qualified electrician. The outdoor unit must be wired directly from a distribution board by means of a circuit breaker or H.R.C. fuse, and a mains isolator provided - preferably close to the unit.

Note: DO NOT USE REWIRABLE FUSES.

The OPA 2000 is provided with a 24V AC control circuit for a thermostat, on/off switch and/or time clock.

The control transformer 240V primary voltage is used for countries with 230-240V power supply. For countries with supply voltages 200-220V, change the primary voltage on the transformer to 208V.

Standard units are suitable for use with thermostats with either manual Heat/Cool selection or automatic changeover subject to the contact ratings of the thermostats.

A 24 hour power supply to the control circuit is required, otherwise the warranty is void.

CHECK TESTS

1. Check that the shipping block beneath the compressor has been removed and that the compressor is secure on its mounts.
2. Check by hand that all fan motors can turn freely.
3. Check that the air filters have been correctly installed, if fitted.
4. Check air diffuser dampers are open if appropriate.
5. Check that the thermostat, or external 24V controller, is correctly wired to the unit and is set at the desired temperature.
6. Check the tightness of all electrical connections and sign the check label.
7. Leave the thermostat, or external 24V controller, in the off position and close the mains isolating switch. (A four hour delay period is required to allow the crankcase heater to drive any liquid refrigerant out of the compressor oil.)

8. Check the supply voltage between each phase and neutral.

START UP PROCEDURE

After the four hour delay for the crankcase heater has expired, use the supplied Commissioning Sheet (Form NS 228) to record results when completing the following 'Start-up' procedure. A UC6 Service Interface tool is supplied to read, pressures, superheat and its set-point, compressor amps etc.

1. Select a sensible Fan speed (or Auto Fan mode), operating cycle (cool or heat), and room temperature set point, depending on the time of year, such that the compressor will start and run at a high capacity.
2. Turn ON the thermostat / External controller. Wait for the compressors to start.
3. Compressors fitted are directional. Check for correct rotation. If rotation is incorrect the compressor will not pump, be noisy, and will draw minimal current. To correct motor rotation, change the phasing at the main power terminal. If changing the phasing, check the indoor air fan then runs in the correct direction also.
3. Measure the current draw on each phase to the compressor motors and measure the current draw of each fan motor. Check all readings against the specified values in the wiring diagram.
4. Use the UC6 Service Interface tool to check operating pressures and status. If the UC6 Service Interface is not available, fit gauges and measure the suction and discharge pressures of both refrigeration circuits.
5. Check that the outdoor air fan motors are running smoothly and drawing less than the full load amps specified.
6. Test the operation of the reversing valve by running the unit in both the heating and cooling mode.
7. Check the supply air flow at each outlet.
8. Touch up any outdoor unit paintwork damage to prevent corrosion.

SETTING SUPPLY AIR FLOW

Consult OPA 2000 Technical Data pamphlet at www.temperzone.biz for details of airflow/duct static pressure, if required.

If the indoor air returning to the unit is regularly expected to be above 50%RH, then the coil face velocity should be limited to be 2.5 m/s or less (refer Air Handling graph in Technical Data pamphlet).

High humidity levels can occur in tropical or subtropical conditions, and/or when heavily moisture laden fresh air is introduced.

Select a fan speed that avoids water carry-over problems.

In a free blow or low resistance application, beware of exceeding the fan motor's full load amp limit (refer wiring diagram).

The indoor air fan motor is fitted with a factory set adjustable pitch pulley. Instructions for the adjustment of pulleys is included on the back page of the supplied Commissioning Sheet. One revolution of adjustment is equal to approx. 7% change in air volume flow rate.

UNIT CONTROLLER (UC6)

The Unit Controller provides system protection functions such as coil frost protection, de-icing, high head pressure and low suction pressure cut-out. It also protects against rapid cycling of the compressor(s) and loss of refrigerant. The UC regulates the superheat of the refrigeration system by controlling the position of an electronic expansion valve (EEV). Various methods of head pressure control (or limiting) are employed in temperzone units. The particular method used varies from model to model, but is also handled by the Unit Controller. In combination, these features deliver optimised performance across a wide operating temperature range.

As a result of the UC's control of these inter-related functions, the outdoor fans may take some time to start rotating after each

compressor start. They may also run on when the compressor stops. The fans will stop during a de-ice cycle and the speed will vary either smoothly, or in steps, in order to protect against excessively low or high head pressure.

Refer to UC6 Controller label on the unit for operation & fault diagnostics information. Many operating status conditions can be determined, without gauges, simply by using the *UC6 Service Interface* graphical display supplied with the unit.

MAINTENANCE

Monthly

1. Check air filters, if fitted, and vacuum or wash clean as necessary.
2. Check condensate drain for free drainage.
3. Check compressor compartment for oil stains indicating refrigerant leaks.

Three Monthly (or every 1200 hrs of operation)

Check the indoor unit's fan belt tension and adjust if necessary.

Six Monthly

1. Check the tightness of electrical connections.
2. Check the tightness of all fans, motor mountings, pulleys and belt tension.
3. Check suction and discharge operating pressures. (Using the *UC6 Service Interface* avoids fitting and removing gauges with consequential refrigerant loss.)

4. Replace indoor air filters (if fitted).
5. Check condensate drain for free drainage.

Yearly

1. Check all refrigerant piping for chafing and vibration.
2. Check the operation of electric heaters, if fitted.
3. Check air supply at all diffusers.
4. Check for excessive noise and vibration and correct as necessary.
5. Check for insulation and duct damage and repair as necessary.
6. Remove lint and dust accumulation from outdoor coil fins. In corrosive environments, the checking and cleaning frequency should be increased.
7. Touch up any paintwork damage to prevent corrosion.

NOTE

The manufacturer reserves the right to make changes in specifications at any time without notice or obligation. Certified data is available on request.

This pamphlet replaces the previous issue no. 3735 dated 12/18. Wiring revision I.

DIMENSIONS (mm)

OPA 2000RKT01 – Horizontal Supply & Return Air

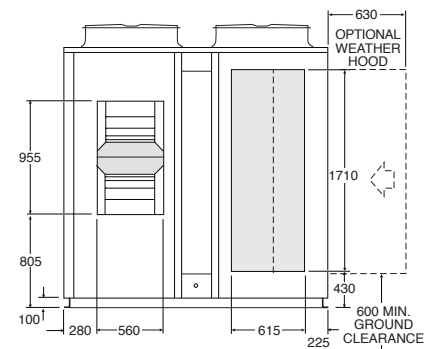
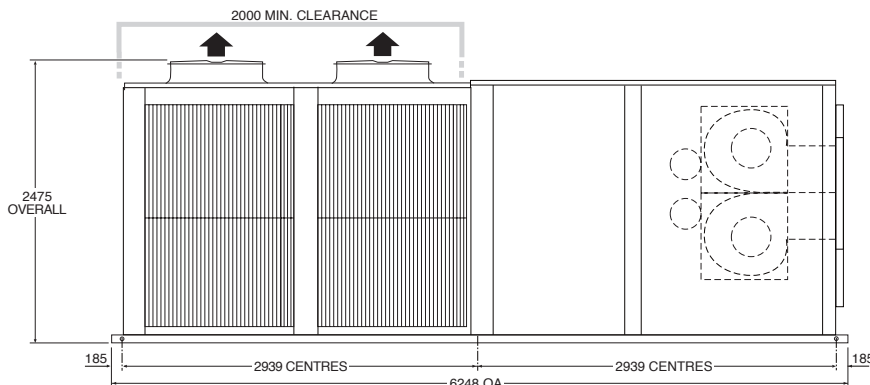
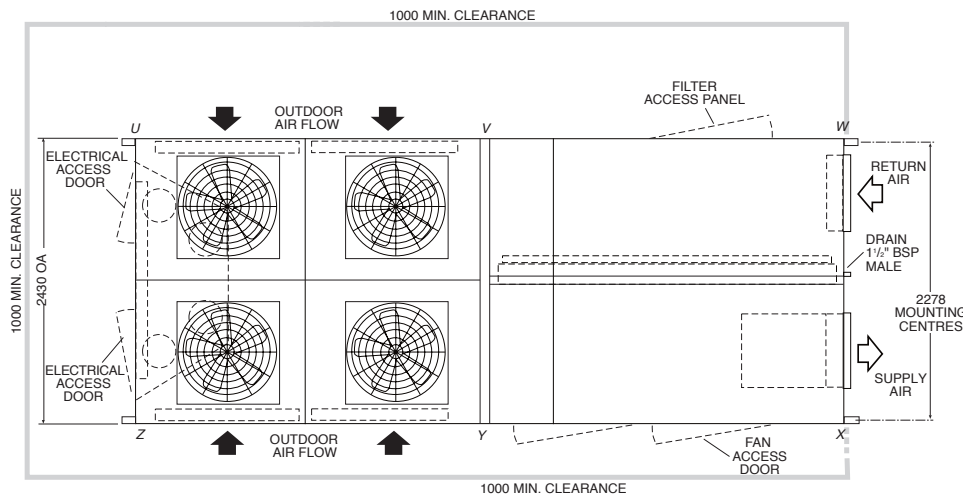

OPA 2000RKT01

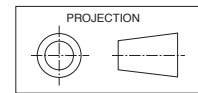

Not to Scale

POINT LOADS (kg)					
U	V	W	X	Y	Z
544	474	415	507	543	587

Net Weight 3070 kg

Note : A 2 m clearance is required above the exhaust air fans

OPA 2000RKTM – Wiring Diagram Part 1, of 2

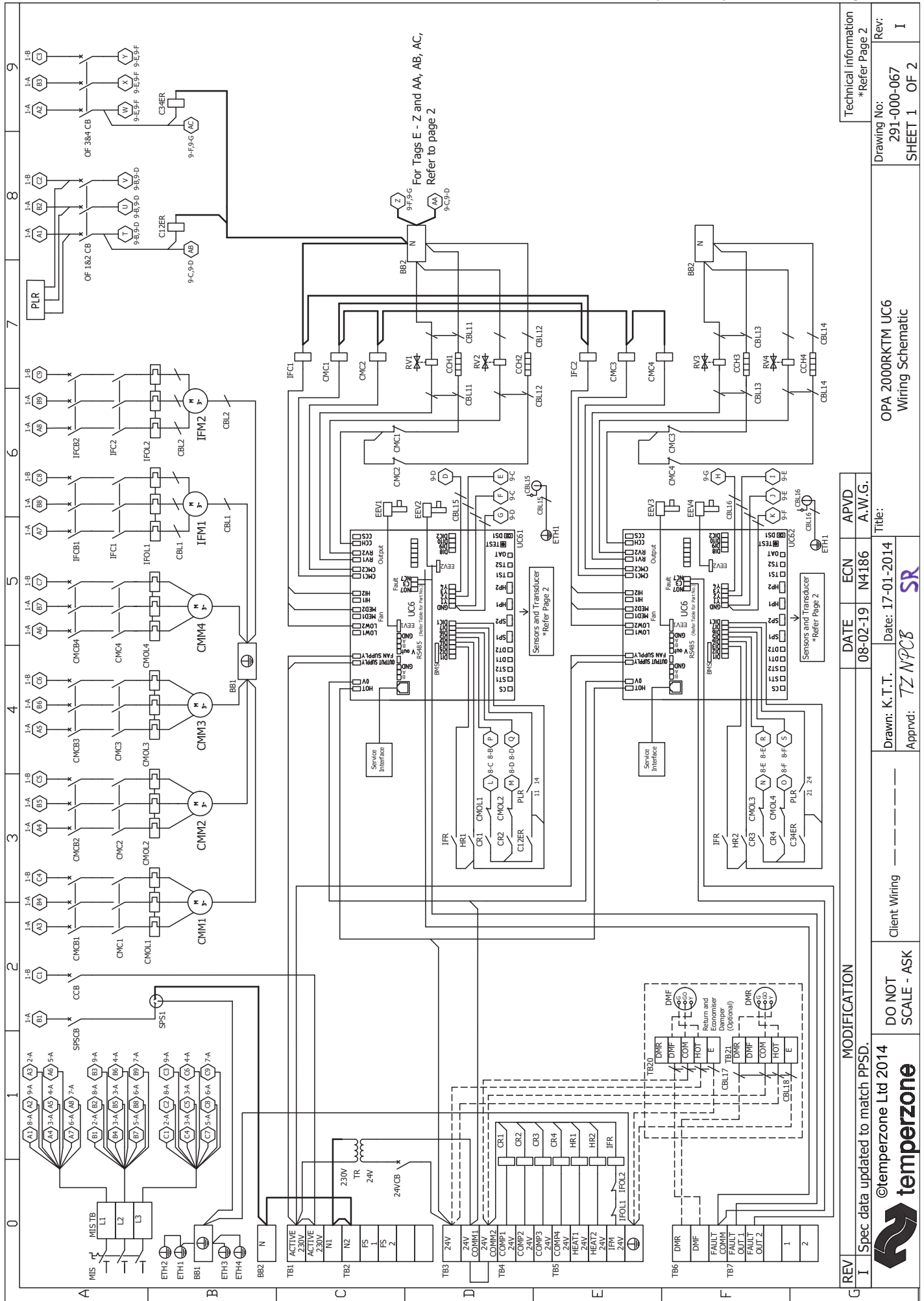

REV	I	Spec data updated to match PSD.	MODIFICATION	DATE	08-02-19	ECN	N4186	APVD	A.W.G.
DO NOT SCALE - ASK			Client Wiring	Drawn: K.T.T.	Date: 17-01-2014	Title:		OPA 2000RKTM UC6 Wiring Schematic	
©temperzone Ltd 2014			temperzone	Apprvd: TZNPCB	SR		Technical information *Refer Page 2		
SHEET 1 OF 2			Drawing No: 291-000-067		Rev: I		SHEET 1 OF 2		

OPA 2000RKTM – Wiring Diagram Part 2, of 2

Options

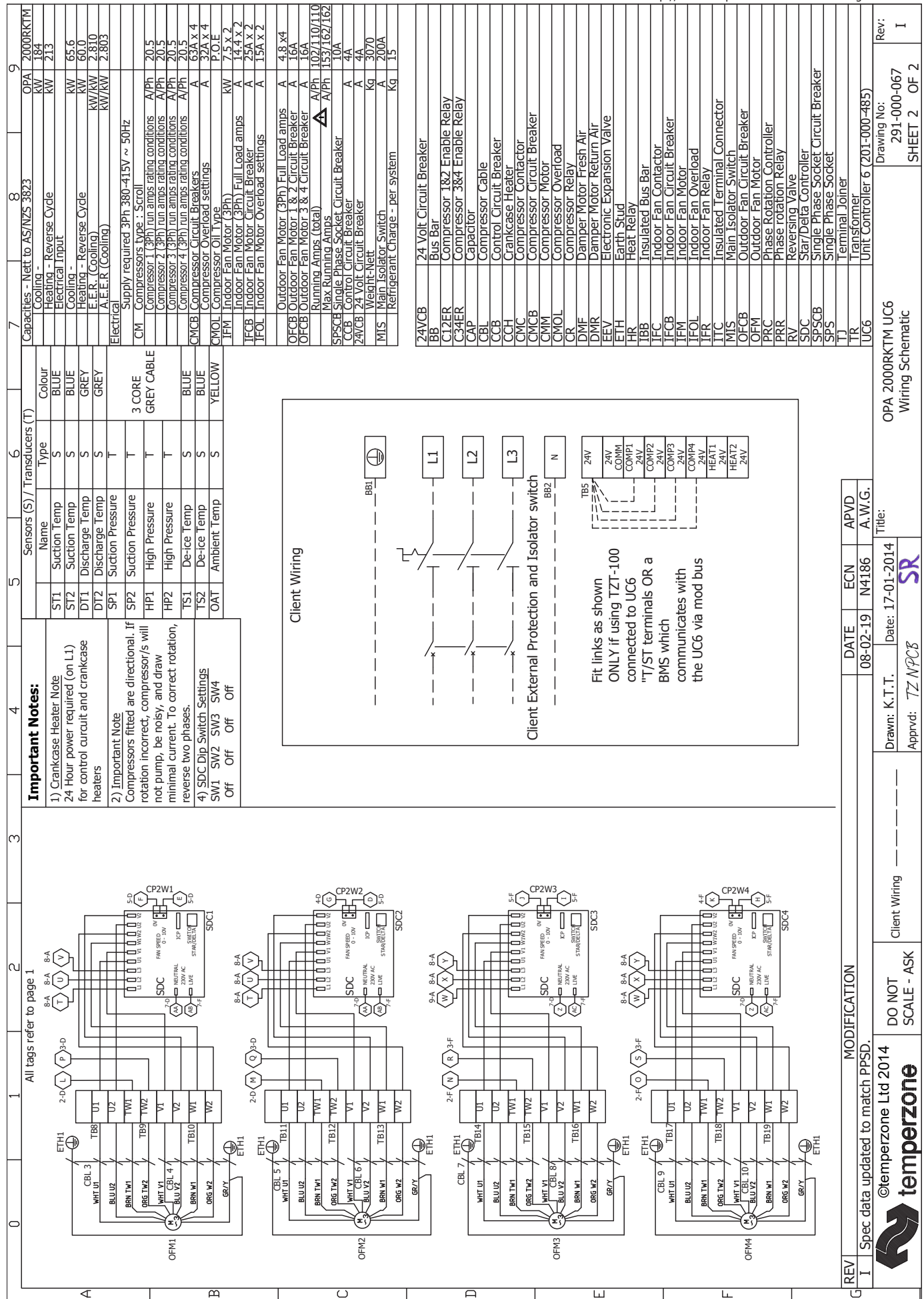

Important Notes:

- 1) Crankcase Heater Note
24 Hour power required (on L1) for control circuit and crankcase heaters
- 2) Important Note
Compressors fitted are directional. If rotation incorrect, compressor/s will not pump, be noisy, and draw minimal current. To correct rotation, reverse two phases.
- 3) SDC Dip Switch Settings
SW1 SW2 SW3 SW4
Off Off Off Off

Client Wiring

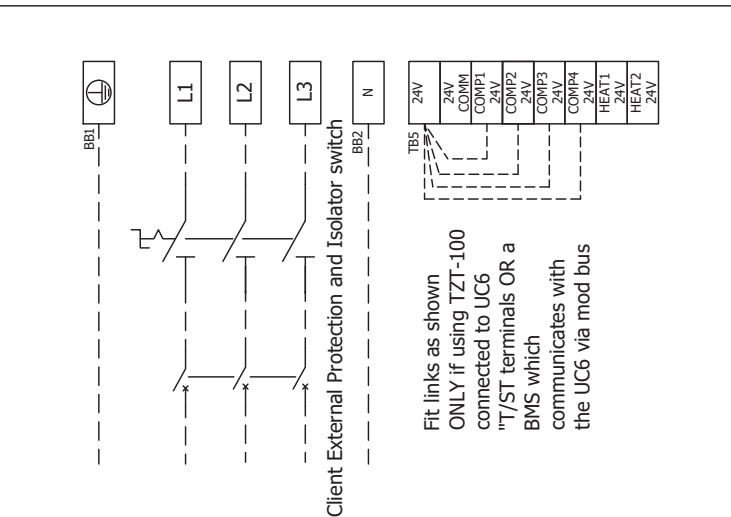

Fit links as shown
ONLY if using TZI-100
connected to UC6
"T/ST terminals OR a
BMS which
communicates with
the UC6 via mod bus

REV	MODIFICATION		
I	Spec data updated to match PPSD.	DATE	ECN
		08-02-19	N4186
	APVD	A.W.G.	



DO NOT SCALE - ASK

Client Wiring

Drawn: K.T.T. Date: 17-01-2014
Apprvd: TZ NTCB

OPA 2000RKTM UC6
Wiring Schematic

Rev: I
Drawing No: 291-000-067
SHEET 2 OF 2