



ISD 280KY (c/w EC motor and Indoor Coil Sensor)

Ducted Split System Indoor Units

Installation & Maintenance

GENERAL

These ISD 280KY indoor units are designed to be coupled with the OSA 280RKT outdoor units. Units must be installed in accordance with all national and local safety codes.

Options

1. Spring Mounting Kit
2. Spigot Plate Adaptor: Ø400mm (4 spigots) part no. 525-411-705

SAFETY DRAIN TRAY

The unit is supplied with an in-built safety drain tray to protect your ceiling against accidental damage.

AIR FILTRATION

As air filtration requirements vary, filters are not supplied with the unit. Filters should ideally be installed on the return air side of the unit, no closer than 500mm from the back of the unit and easily accessible for cleaning. To maximise the efficiency of air flow, the return air filter should be twice the area of the ISD unit's return air spigot/s.

SEPARABLE (Option)

Each model is made up of two parts, a fan section and a coil section (refer fig.2). Separation permits ease of installation through small man holes (minimum 550 mm sq. clear aperture). To separate, undo the screws holding the two parts together. Disconnect the two sensor wires that run between the two parts at the control board. Remember to reconnect these two wires to the same place when re-assembling. Make sure the contact seals are tightly sealed all the way around when reassembling the two sides.

It may be desirable in some applications to keep the two separate parts of the unit apart and joined by ducting, eg over a ceiling joist. A pair of the optional Spigot Plate Adaptors are available to facilitate this option. Two additional fixed mounting brackets are supplied with each adaptor.

INSTALLATION

Positioning & Mounting

Provide 500 mm minimum clearance to both ends of the unit.

If low noise is a critical factor in the installation, refer to Figure 6 for noise isolation recommendations.

It is recommended that the unit be mounted using the spring mounting system, supplied as an optional extra (Fig.7). This system minimises transfer of vibration into the building structure.

If a more rigid installation can be tolerated, then suspend the unit from four threaded rods (not supplied) attached to the ceiling. Four 'L' shaped brackets are supplied on the unit to facilitate this method. These brackets must first be unscrewed, reversed and resecured to enable rod attachment.

The unit has a built-in sloping drain tray, therefore mount it level.

When finally positioned, tighten the lock nuts on the mounting rods from above and below the mounting flange to give a firm installation (see Fig. 4).

Fig. 1 Dimensions (mm)

Not to Scale

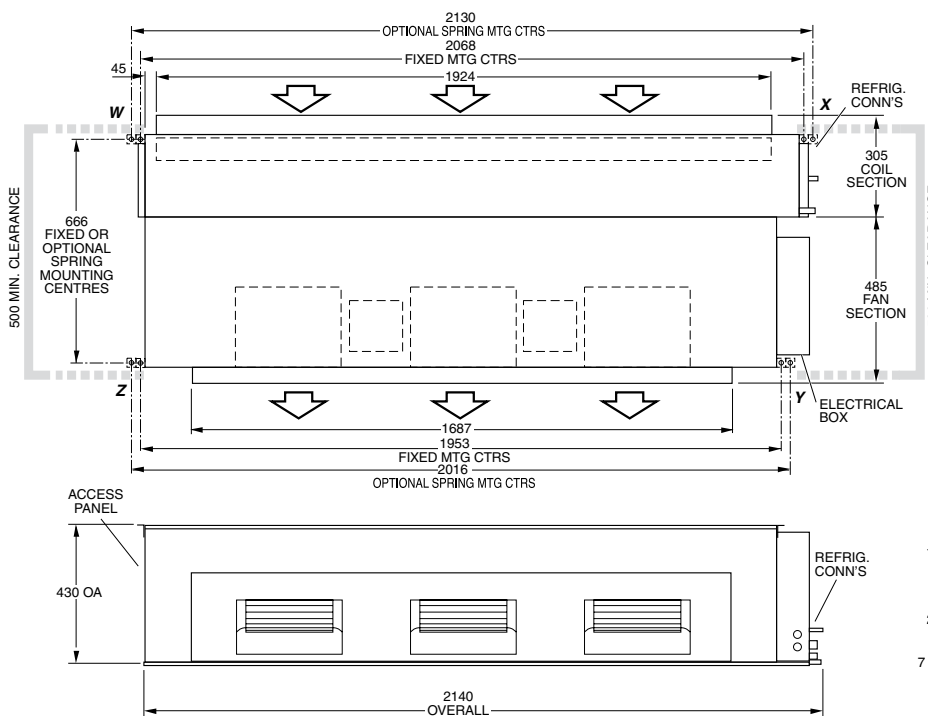
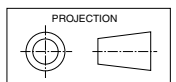

CORNER LOADS (kg)			
W	X	Y	Z
36	42	37	35

Net Weight 150 kg

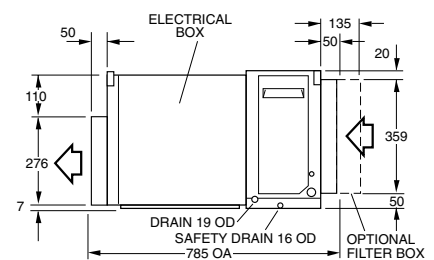

Condensate Drains

The condensate drain should be trapped outside the unit cabinet. The trap should have a vertical height of at least 50 mm. The drain should have a slope of at least 1 in 50 and must not be piped to a level above the unit drain tray. (Refer Fig.5).

For long condensate pipe runs, fit a vent pipe near the drain trap. The top of the vent pipe must be at least 100 mm above the ISD unit's drain tray.

It is essential that the drainage system for the evaporator is checked by pouring water in the drain tray and seeing that it discharges at the end of the drain and does not overflow the drain tray.

Connect the safety drain tray drain pipe to a suitable drain line with an appropriate slope to allow free drainage. This drain line does not require trapping. Test the drain with water to ensure it clears safely.

INDOOR-OUTDOOR UNIT CONNECTIONS

Refer to the relevant OSA Outdoor Unit 'Installation & Maintenance' pamphlet for piping instructions. For wiring connections, refer to the Outdoor Unit wiring diagram in conjunction with the ISD wiring diagram in this pamphlet.

REFRIGERATION PIPING

Pipe Connection Sizes (mm OD) & Type

Liquid: 13 (1/2") sweat

Suction: 28 (9/8") sweat

The ISD is shipped from the factory with a pressurised holding charge of nitrogen. Immediately before removing any brazed pipe connection's seal, reduce the holding charge to atmospheric pressure.

Warning: Failure to do so may cause injury.

Refer to the Outdoor Unit 'Installation & Maintenance' pamphlet for evacuation procedure and piping requirements.

ELECTRICAL WIRING

The electrical supply required (via the Outdoor Unit) is specified on the Outdoor Unit's wiring diagram.

Electrical work must be carried out by a qualified electrician in accordance with local supply authority regulations and the wiring diagram.

This unit includes a coil temperature sensor (yellow) fitted to a pocket on the coil. This must be connected to the UC7 Controller terminal 'IC' in the outdoor unit using the 25 m extension lead supplied.

In a free blow or low resistance application, beware of exceeding the fan motor's full load amp limit (refer Outdoor Unit's wiring diagram).

Note: The SAT-2 Controller automatically switches the indoor fan off during de-ice, therefore no additional wiring is required to achieve this result.

INDOOR FAN SPEED

The indoor fan speed can be 'Stepped' or 'Continuously Variable'. The choice is made using Switch 1 of 'DIP1' on the EC Motor Controller. Switches 1 to 5 on 'DIP2' determine the minimum and maximum fan speeds.

The same 'Minimum rpm' and 'Maximum rpm' settings apply to 'Stepped' and 'Continuously Variable'.

Fig. 2 Separable (Option)

Separable for ease of installation through small man holes
– minimum 550 mm sq. clear aperture

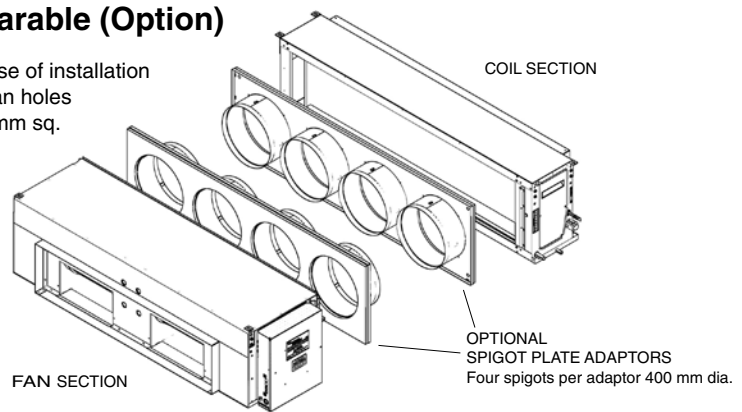

Fig. 3 Spring Mounting



Fig. 4 Solid Mounting

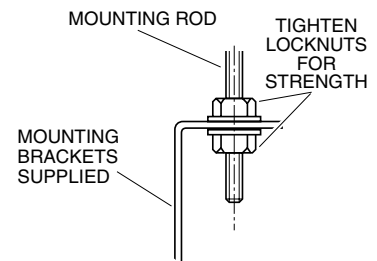
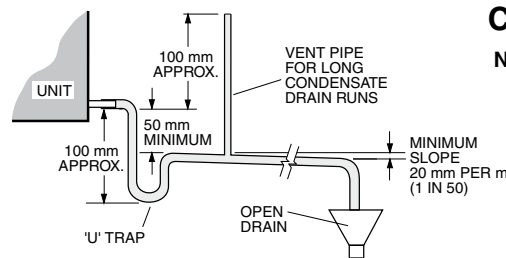

Fig. 5



Condensate Drain

Note: The Safety Drain Tray does not require trapping.

The default settings for DIP1 and DIP2 are highlighted on the Wiring Schematic.

- 1. Stepped (DIP1 switch 1 = OFF)**
Connecting the 24V AC power from the unit's 'HOT 24V' terminal to one (and only one at a time) of the 'LOW 24V' / 'MED 24V' / 'HIGH 24V' terminals, selects the 'LOW' (Min. rpm), 'HIGH' (Max. rpm), or 'MED' (mid-way between) fan speed. The transitions between speeds are smooth.
- 2. Continuously Variable (DIP1 switch 1=ON)**
When using this method a temperzone Analog Signal Isolator (No. 201-000-129) must be fitted and connected as shown in the wiring schematic. 24V AC or DC power from the external (BMS) controller should be provided to the '24V' and '0V' input terminals of the Signal Isolator board.

A voltage below 2V DC applied across the '0V' and the '0-10V' input terminals (labelled 'From BMS Controller' in the wiring schematic) of the Signal Isolator will stop the indoor fan. A control voltage of slightly more than 2V will cause the fan to run at the 'Min. rpm' speed. A 10V DC signal will run the fan at the 'Max. rpm' speed. Control voltages between these two limits can be used to achieve any desired speed between 'Min.' and 'Max.' rpm.

Do not use switch combinations marked with 'DO NOT USE' in the Speed Selection table.

If the air returning to the indoor unit is regularly expected to be above 50%RH, then the coil face velocity should be limited to be 2.5 m/s or less (refer Air Handling graph in Technical Data pamphlet).

High humidity levels can occur in tropical or subtropical conditions, and/or when heavily moisture laden fresh air is introduced. Select a fan speed that avoids water carry-over problems.

THERMOSTATS

A dedicated neutral line is required where electronic or anticipator thermostats are used when you choose to have indoor fan off in de-ice.

COMMISSIONING

Indoor Unit

1. Check that the thermostat is correctly wired and set at the desired temperature.
2. Check that the air filter (if fitted) is clean.
3. Check that the fan runs freely without vibration.
4. Check condensate drain and safety drain tray for free drainage.

Refer to Outdoor Unit Installation Instructions in order to complete the start-up and commissioning procedure for the complete air conditioning system.

MAINTENANCE

Weekly For First Four Weeks

1. Check air filter (if fitted); vacuum clean as necessary.
2. Check condensate drain for free drainage.

Monthly

Check air filter (if fitted); vacuum clean as necessary.

Six Monthly

1. Check condensate drain and safety drain tray for free drainage.
2. Check heat exchanger coil; vacuum or brush clean as necessary.

3. Check the tightness of the fan.
4. Check that fan motor is free running.
5. Check tightness of electrical connections.
6. Check air supply at diffuser outlets.

WARNING

This unit is designed for use ONLY with the refrigerant HFC-410A (R410A). The use of other refrigerants is NOT authorised or approved by the manufacturer and may cause operational problems such as poor performance and efficiency, loss of capacity, degradation of materials and refrigerant leaks.

The use of flammable or explosive materials as a refrigerant creates the additional risks of fire and explosion which may result in property damage, personal injury or death.

NOTE

The manufacturer reserves the right to change specifications at any time without notice or obligation. Certified dimensions available on request.

This pamphlet replaces the previous issue no. 3819 dated 08/12. Dimensions.

Fig. 7 Application Considerations

Recommendations for Noise Isolation

- particularly for high static installations:

1. Avoid installing units, with non-ducted return air, directly above spaces where noise is critical.
2. Use flexible connections between unit and rigid ducting.
3. Use generously sized acoustically lined ducts.
4. If generous duct size is not possible, use turning vanes on bends to reduce air turbulence (regenerated noise).
5. Use 90° bends in ducting to significantly assist in noise reduction.

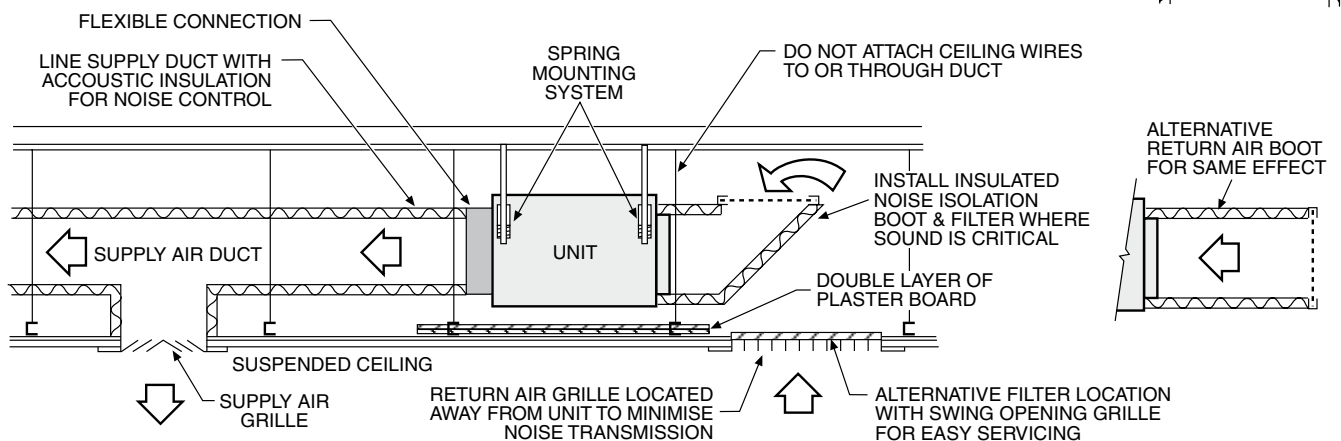
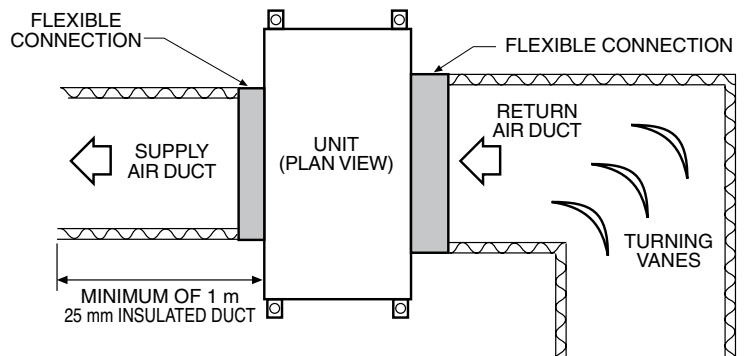

EC-Board speed selection(0.9-1.25KW) - DIP Switch 2 (DIP2)

DO NOT USE ANY OTHER DIP SWITCH COMBINATIONS EXCEPT THOSE SHOWN IN THE TABLE ADJACENT.



Switch 1	Off	Off	Off	Off
Switch 2	Off	On	Off	Off
Switch 3	On	On	Off	On
Switch 4	Off	Off	On	On
Switch 5	Off	Off	Off	Off
Max (rpm)	1350	1300	1200	1100
Min (rpm)	1050	1000	900	800

Model	ISD 280KBY
Voltage In	V 230/240
IFM #1 (0.90KW)	Amps (MAX) 5 A
IFM #2 (1.25KW)	Amps (MAX) 8 A

LR	Low Speed Relay
LRC	Low Speed Relay Coil
MR	Med Speed Relay
MRC	Med Speed Relay Coil
FRB	Fault Relay Board
HR	HI Speed Relay
HRC	HI Speed Relay Coil
IFM	Indoor Fan Motor
ECC	EC Motor Controller
DR	De-ice Relay
DRC	De-ice Relay Coil

Refer to website www.temperzone.biz for up to date information

Client wiring
Insulated multi-core cable.
Interconnections between units
by client. Double insulated.

De-ice note: For "indoor" fan off during de-ice cycle, connect to OUC's de-ice n/o terminal.

Do not connect to 'de-ice' on outdoor unit's terminal block.

Standard setting	Off	On
1	Off	On
2	On	Off
3	Off	On
4	Off	On

Off	3 Speed Fan Hi/Med/Low	On	0-10V Control
Normal forward Action	900W & 1.25KW Motor	Reverse action	Reverse action
Leave in this Position		Do not use	Do not use

ISD 280KY
Wiring schematic (c/w indoor coil sensor)



Drawn S.D.H.	Date	Revision
Scale	291-000-050	A

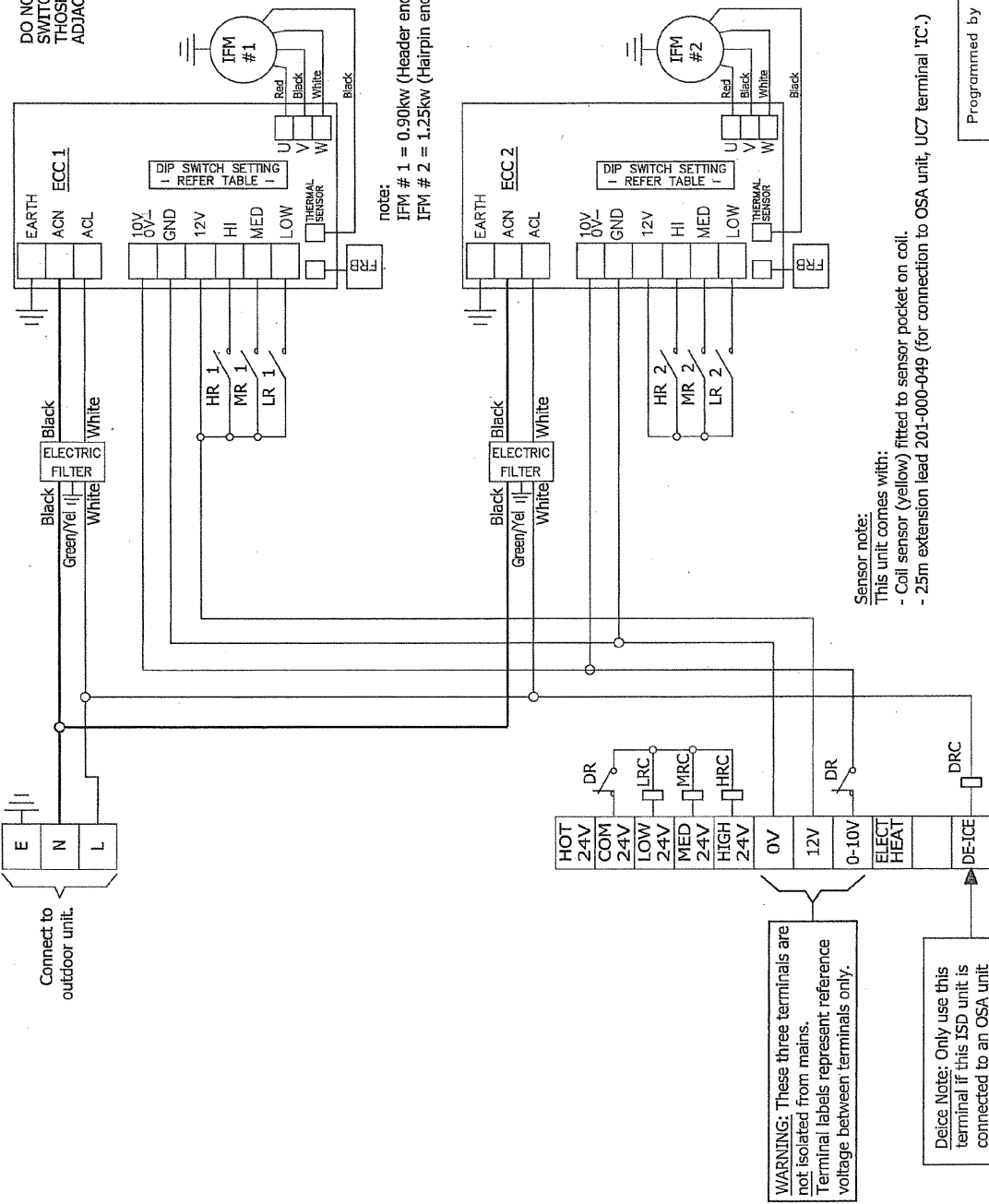

note:
IFM # 1 = 0.90kw (Header end)
IFM # 2 = 1.25kw (Hairpin end)

Sensor note:
This unit comes with:
- Coil sensor (yellow) fitted to sensor pocket on coil.
- 25m extension lead 201-000-049 (for connection to OSA unit, UC7 terminal 'IC'.)

WARNING: These three terminals are not isolated from mains. Terminal labels represent reference voltage between terminals only.

Deice Note: Only use this terminal if this ISD unit is connected to an OSA unit with an OUC controller

Programmed by	Plotted
	12-09-12
	©temperzone ltd
	2012

ISSUE	MODIFICATION	DRG No.	DESCRIPTION	Mat'l	FINISH	ASSY No.
A	Set Dip 1, Switch No.3 to the "OFF" Position/Speed Selection Table Mod	N3113				
		12-09-12	J.S.L.			