

Contents: *(click on page links below)*

| | |
|-------------------------------------|-----------|
| General Data | 1 |
| Square Performance Data | 4 |
| Rectangular Performance Data | 8 |
| Suggested Spec | 26 |
| Accessories | 27 |



AUCKLAND
ph 09 279 5250
fax 09 275 5637
sales@temperzone.co.nz

WELLINGTON
ph 04 569 3262
fax 04 566 6249
wgtn@temperzone.co.nz

CHRISTCHURCH
ph 03 379 3216
fax 03 379 5956
chch@temperzone.co.nz

HEAD OFFICE (Auckland)
38 Tidal Road, Mangere, Auckland 2022, NZ
Private Bag 93303, Otahuhu, Auckland 1640, NZ



SH SERIES Ceiling Diffusers

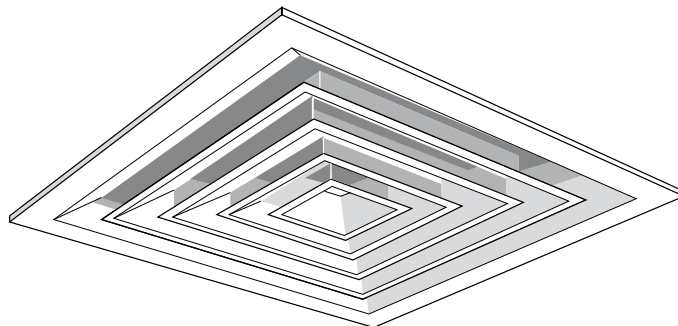

General

The SH Series square and rectangular ceiling diffusers are available in a variety of sizes and air patterns.

Design

The SH Series diffuser core has angled louvre blades with a horizontal lip on the leaving edge providing a horizontal air pattern which is tight to the ceiling. In most applications it is suitable for use with ceiling heights up to 3.3 m. For higher ceiling applications, use the SHPC Series diffuser

The SH Series maintains an unbroken horizontal air pattern from maximum to minimum air flow providing an excellent choice for use with variable air volume systems.

Performance Data

For detailed Performance Data refer to the following Performance Data pages

Frames

The SH Series has a flat frame that maintains a low unobtrusive profile against any ceiling. A bevelled anti-smudge frame is available to special order.

Cores

SH Series diffuser cores are removable from the outer frame of the diffuser. They are available in a full range of air patterns that are interchangeable to suit changing room layouts (see page 3).

Cores simply clip in to the outer frame for convenience and flexibility in application.

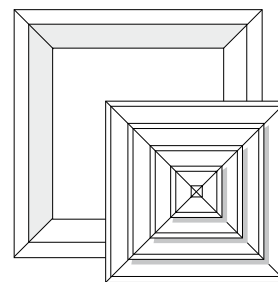

Sizes (mm)

Square or rectangular nominal (duct) sizes are available in the following 75 mm increment range:

150, 225, 300, 375, 450, 525, 600, 675, 750, 825, 900.

Stocks of the popular sizes and air patterns, in white gloss finish, are available at your nearest **temperzone** sales office.

Finishes

Stock colour is powder coat, white gloss. Alternative colours and finishes available.

Construction

Frame and cores are of corrosion resistant aluminium construction.

SH SERIES DIFFUSERS

Dimensions (mm)

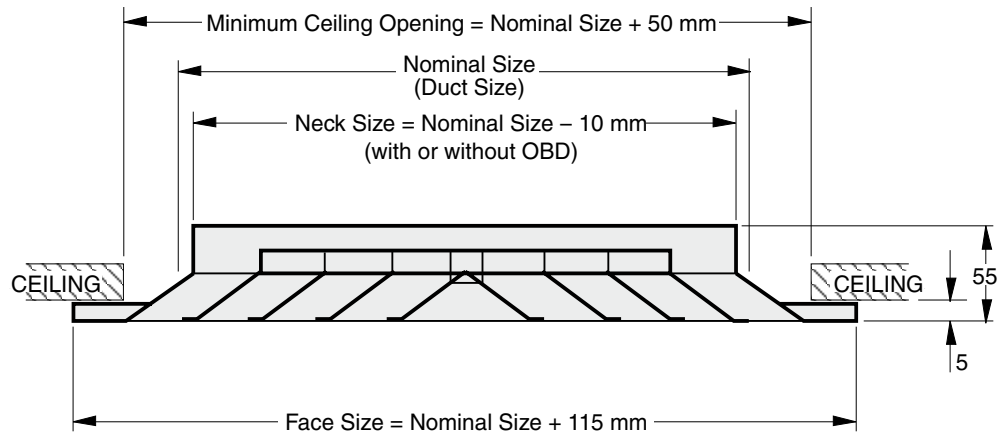

Note: Nominal size 450 mm sq. diffuser has a face size of 595 mm sq. which will lay in a 600 mm T-rail system.

SH Series Options

Plaque (PLQ)

- Provides rigid support for diffuser installed in suspended tile ceilings
- Full or half tile sizes
- Supplied factory fitted to diffuser
- Lay-in style
- Powder coated electro-galvanised steel

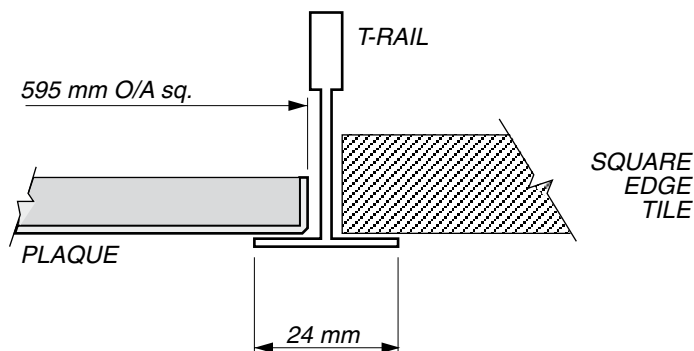
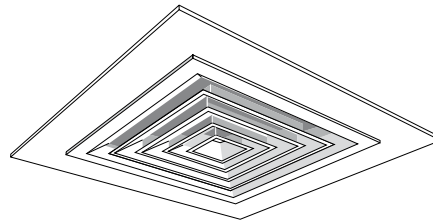

Bevelled Frame

- Accentuates appearance
- Protects ceiling against dust marks
- Available to special order

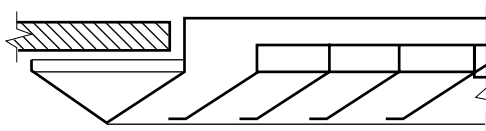

AIR PATTERNS

Note: Patterns are in plan view, i.e. viewed from neck side.
A = Primary Throw, **B** = Secondary Throw

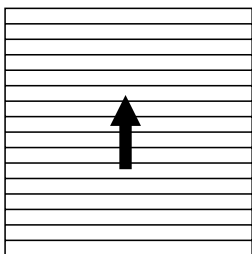
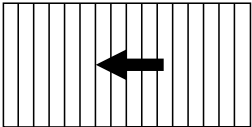
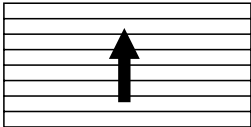
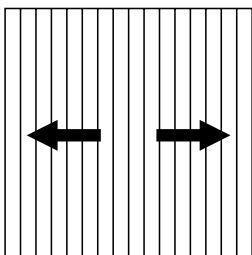
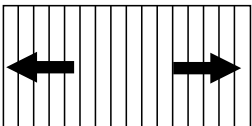
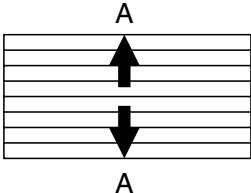
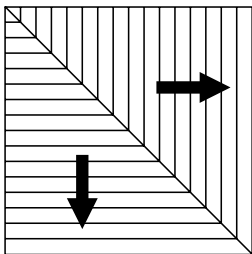
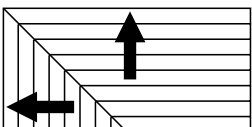
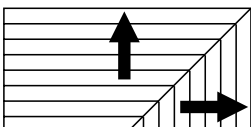
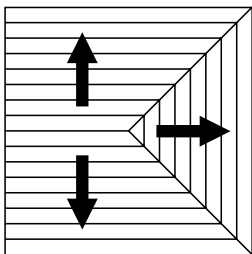
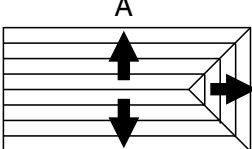
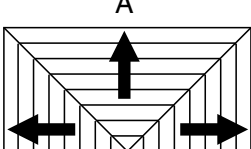
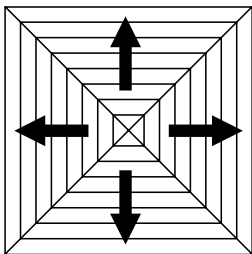
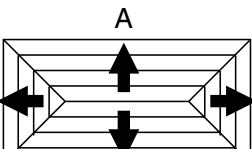
| Order Codes | Square | Rectangular | |
|---|--|---|--|
| 1-Way SH1 SH1S SH1L | 1 <div style="text-align: center;">A</div>  | 1S  | 1L  |
| 2-Way Opposite SH2 SH2S SH2L | 2  | 2S  | 2L  |
| 2-Way Diagonal SHD2 SHD2LL SHD2LR | D2  | D2LL  | D2LR  |
| 3-Way SH3 SH3S SH3L | 3 <div style="text-align: center;">A</div>  | 3S  | 3L  |
| 4-Way SH4 SH4R | 4 <div style="text-align: center;">A</div>  | 4R  | |

PERFORMANCE DATA TABLES

Definitions:

Neck Velocity (m/s)

Measured at the neck - the point where the diffuser attaches to the duct.

Total Pressure (Pa)

Stated for a diffuser without Opposed Blade Dampers (OBDs).

Noise Criteria (NC)

Sound levels are based on a room attenuation of 10 dB (SWL re 10⁻¹² watts) with one diffuser operating.

Guide for Environmental Sound Level Design

| <i>Environment</i> | <i>Suggested NC Range</i> | <i>Environment</i> | <i>Suggested NC Range</i> |
|------------------------------|---------------------------|------------------------------|---------------------------|
| Broadcast, Recording Studios | 15 - 20 | Retail Stores & Shops | 35 - 45 |
| Concert / Opera Halls | 20 - 25 | General Offices, Schools | 35 - 45 |
| Residences, Bedrooms | 25 - 35 | Swimming Centres, Gymnasiums | 35 - 50 |
| Hospitals | 25 - 35 | Kitchens | 40 - 50 |
| Theatres, Halls, Churches | 25 - 30 | Factories | |
| Cinemas | 30 - 35 | - Light Engineering | 45 - 65 |
| Private Offices, Libraries | 30 - 35 | - Heavy Engineering | 55 - 75 |
| Restaurants, Bars | 35 - 45 | | |

Throw (m)

Based on isothermal air, for diffusers flush mounted to a ceiling.

For diffusers, mounted on exposed ductwork, throws will be approximately 70% of Performance Data values.
For diffusers fitted with UltraThro, the throw will be approximately 80% of Performance Data values.

The Performance Data Charts state throw values per side in metres at three terminal velocities (as follows);

Terminal Velocities (m/s)

Throw 1 : 0.75 m/s

Throw 2 : 0.50 m/s

Throw 3 : 0.25 m/s

Performance Data

SH Square Diffusers

| Nominal Size (mm) | Air Pattern (viewed from neck) | Neck Vel. (m/s) | 1.5 | 2.0 | 2.5 | 3.0 | 3.5 | 4.0 | 4.5 |
|-------------------|--------------------------------|-------------------|-----|-----|-----|-----|-----|-----|-----|
| | | Total Press. (Pa) | 11 | 19 | 29 | 42 | 57 | 75 | 94 |

| | | | | | | | | | | | | | | | | | |
|-----------------|-----|--------------------------|---------------------|----------|--------------|----------|--------------|----------|--------------|----------|------------------|------------------|--------------|----------|---------------|----------|-----|
| 150 X 150 | | Total l/s NC Side | 35 < 10 | | 47 13 | | 59 19 | | 71 23 | | 83 27 | | 94 31 | | 106 34 | | |
| | | | A | B | A | B | A | B | A | B | A | B | A | B | A | B | |
| | SH1 | | l/s per side | | 35 | 47 | 59 | 71 | 83 | 94 | 106 | Throw (m) | | 1 | 2 | 3 | |
| | | | 1 | 2 | 3 | 2.1 | 2.7 | 3.0 | 3.4 | 3.7 | 4.0 | 4.6 | 4.0 | 4.9 | 5.2 | 5.8 | 6.4 |
| | | | 2 | 3 | 4.0 | 4.9 | 5.5 | 5.8 | 6.4 | 6.7 | 7.3 | | | | | | |
| SH2 | | l/s per side | | 18 | 24 | 30 | 35 | 42 | 47 | 53 | Throw (m) | | 1 | 2 | 3 | | |
| | | 1 | 2 | 3 | 0.9 | 1.5 | 1.8 | 2.1 | 2.4 | 2.7 | 3.0 | 2.7 | 3.0 | 3.7 | 4.0 | 4.6 | |
| | | 2 | 3 | 3.0 | 3.7 | 4.0 | 4.3 | 4.6 | 5.2 | 5.5 | | | | | | | |
| SHD2 | | l/s per side | | 18 | 24 | 30 | 35 | 42 | 47 | 53 | Throw (m) | | 1 | 2 | 3 | | |
| | | 1 | 2 | 3 | 0.9 | 1.2 | 1.8 | 2.1 | 2.4 | 2.7 | 3.0 | 2.4 | 2.7 | 3.7 | 4.0 | 4.6 | |
| | | 2 | 3 | 3.0 | 3.7 | 4.0 | 4.3 | 4.6 | 5.2 | 5.5 | | | | | | | |
| SH3 | | l/s per side | | 13 | 9 | 18 | 12 | 22 | 15 | 26 | 18 | 31 | 21 | 35 | 24 | 40 | 26 |
| | | 1 | 2 | 3 | 0.9 | 0.9 | 1.2 | 1.2 | 1.8 | 1.5 | 2.1 | 1.8 | 2.4 | 2.1 | 2.4 | 2.1 | 2.7 |
| | | 2 | 3 | 1.5 | 1.2 | 2.1 | 1.8 | 2.4 | 2.1 | 2.7 | 2.4 | 2.7 | 2.4 | 3.0 | 2.7 | 3.4 | 2.7 |
| | | 3 | 2.7 | 2.4 | 3.0 | 2.7 | 3.4 | 3.0 | 3.4 | 4.0 | 3.4 | 4.3 | 3.7 | 4.6 | 4.0 | 4.9 | 4.0 |
| SH4 | | l/s per side | | 9 | 12 | 15 | 18 | 21 | 24 | 26 | Throw (m) | | 1 | 2 | 3 | | |
| | | 1 | 2 | 3 | 0.9 | 1.2 | 1.5 | 1.8 | 2.1 | 2.4 | 2.7 | 2.1 | 2.7 | 3.0 | 3.4 | 3.7 | 4.0 |
| | | 2 | 3 | 1.2 | 1.8 | 2.1 | 2.7 | 3.0 | 3.4 | 4.0 | 4.3 | 4.6 | 5.2 | 5.5 | 6.1 | 6.7 | 7.3 |







| | | | | | | | | | | | | | | | | | |
|-----------------|-----|--------------------------|---------------------|----------|---------------|----------|---------------|----------|---------------|----------|------------------|------------------|---------------|----------|---------------|----------|------|
| 225 X 225 | | Total l/s NC Side | 80 < 10 | | 106 15 | | 133 21 | | 160 26 | | 186 30 | | 212 34 | | 239 37 | | |
| | | | A | B | A | B | A | B | A | B | A | B | A | B | A | B | |
| | SH1 | | l/s per side | | 80 | 106 | 133 | 160 | 186 | 212 | 239 | Throw (m) | | 1 | 2 | 3 | |
| | | | 1 | 2 | 3 | 3.4 | 4.0 | 4.6 | 5.2 | 5.8 | 6.1 | 6.7 | 7.3 | 7.6 | 8.2 | 8.8 | 9.5 |
| | | | 2 | 3 | 4.3 | 5.2 | 5.8 | 6.1 | 6.7 | 7.3 | 7.6 | 8.2 | 8.8 | 9.5 | 10.4 | 11.0 | 11.0 |
| SH2 | | l/s per side | | 40 | 53 | 67 | 80 | 93 | 106 | 119 | Throw (m) | | 1 | 2 | 3 | | |
| | | 1 | 2 | 3 | 1.5 | 2.1 | 2.7 | 3.4 | 4.0 | 4.6 | 4.9 | 5.5 | 5.8 | 6.1 | 6.7 | 7.0 | |
| | | 2 | 3 | 2.4 | 3.4 | 4.3 | 4.6 | 4.9 | 5.5 | 5.8 | 6.1 | 6.7 | 7.0 | 7.6 | 8.2 | 8.2 | |
| SHD2 | | l/s per side | | 40 | 53 | 67 | 80 | 93 | 106 | 119 | Throw (m) | | 1 | 2 | 3 | | |
| | | 1 | 2 | 3 | 1.5 | 2.1 | 2.7 | 3.4 | 4.0 | 4.6 | 4.9 | 5.5 | 5.8 | 6.1 | 6.7 | 7.0 | |
| | | 2 | 3 | 2.4 | 3.4 | 4.3 | 4.6 | 4.9 | 5.5 | 5.8 | 6.1 | 6.7 | 7.0 | 7.6 | 8.2 | 8.2 | |
| SH3 | | l/s per side | | 30 | 20 | 40 | 26 | 50 | 33 | 60 | 40 | 70 | 46 | 80 | 53 | 90 | 60 |
| | | 1 | 2 | 3 | 1.5 | 1.2 | 2.1 | 1.8 | 2.7 | 2.4 | 3.4 | 2.7 | 3.7 | 3.4 | 4.0 | 3.7 | 4.3 |
| | | 2 | 3 | 2.4 | 2.1 | 3.4 | 2.7 | 3.7 | 3.4 | 4.0 | 3.7 | 4.3 | 4.0 | 4.9 | 4.0 | 4.9 | 4.3 |
| | | 3 | 4.0 | 3.7 | 4.9 | 4.0 | 5.2 | 4.6 | 5.8 | 5.2 | 6.4 | 5.5 | 6.7 | 5.8 | 7.3 | 6.1 | |
| SH4 | | l/s per side | | 20 | 26 | 33 | 40 | 46 | 53 | 60 | Throw (m) | | 1 | 2 | 3 | | |
| | | 1 | 2 | 3 | 1.2 | 1.8 | 2.4 | 2.7 | 3.0 | 3.4 | 4.0 | 3.4 | 4.0 | 4.3 | 4.3 | 4.3 | |
| | | 2 | 3 | 2.1 | 2.7 | 3.4 | 3.7 | 4.0 | 4.0 | 4.0 | 4.0 | 4.0 | 4.0 | 4.0 | 4.0 | 4.3 | |
| | | 3 | 3.7 | 4.0 | 4.0 | 4.6 | 5.2 | 5.5 | 5.8 | 6.1 | 6.7 | 7.0 | 7.6 | 8.2 | 8.2 | 8.2 | |







| | | | | | | | | | | | | | | | | | |
|-----------------|-----|--------------------------|---------------------|----------|---------------|----------|---------------|----------|---------------|----------|------------------|------------------|---------------|----------|---------------|----------|------|
| 300 X 300 | | Total l/s NC Side | 142 10 | | 189 17 | | 236 23 | | 283 28 | | 330 32 | | 378 35 | | 425 38 | | |
| | | | A | B | A | B | A | B | A | B | A | B | A | B | A | B | |
| | SH1 | | l/s per side | | 142 | 189 | 236 | 283 | 330 | 378 | 425 | Throw (m) | | 1 | 2 | 3 | |
| | | | 1 | 2 | 3 | 4.6 | 5.5 | 6.1 | 6.7 | 7.3 | 7.9 | 8.2 | 8.2 | 8.8 | 9.1 | 9.8 | 10.4 |
| | | | 2 | 3 | 5.8 | 6.7 | 7.6 | 8.2 | 8.8 | 9.5 | 10.4 | 11.0 | 11.9 | 12.8 | 13.7 | 14.6 | 14.6 |
| SH2 | | l/s per side | | 71 | 94 | 118 | 142 | 165 | 189 | 212 | Throw (m) | | 1 | 2 | 3 | | |
| | | 1 | 2 | 3 | 2.1 | 3.0 | 3.7 | 4.6 | 5.2 | 5.8 | 6.1 | 6.7 | 7.3 | 7.6 | 8.2 | 8.2 | |
| | | 2 | 3 | 3.4 | 4.6 | 5.8 | 6.1 | 6.7 | 7.3 | 7.6 | 8.2 | 8.8 | 9.5 | 10.4 | 11.0 | 11.0 | |
| SHD2 | | l/s per side | | 71 | 94 | 118 | 142 | 165 | 189 | 212 | Throw (m) | | 1 | 2 | 3 | | |
| | | 1 | 2 | 3 | 2.1 | 3.0 | 3.7 | 4.6 | 5.2 | 5.8 | 6.1 | 6.7 | 7.3 | 7.6 | 8.2 | 8.2 | |
| | | 2 | 3 | 3.4 | 4.6 | 5.8 | 6.1 | 6.7 | 7.3 | 7.6 | 8.2 | 8.8 | 9.5 | 10.4 | 11.0 | 11.0 | |
| SH3 | | l/s per side | | 53 | 35 | 71 | 47 | 89 | 59 | 106 | 71 | 124 | 83 | 142 | 94 | 160 | 106 |
| | | 1 | 2 | 3 | 2.1 | 1.8 | 2.7 | 2.4 | 3.7 | 3.4 | 4.3 | 4.0 | 4.9 | 4.3 | 5.2 | 4.6 | 5.5 |
| | | 2 | 3 | 3.4 | 2.7 | 4.3 | 4.0 | 4.9 | 4.3 | 5.5 | 4.9 | 5.8 | 5.2 | 6.4 | 5.5 | 6.7 | 5.8 |
| | | 3 | 5.5 | 4.9 | 6.4 | 5.5 | 7.0 | 6.1 | 7.9 | 6.7 | 8.5 | 7.3 | 9.1 | 7.9 | 9.8 | 8.2 | |
| SH4 | | l/s per side | | 35 | 47 | 59 | 71 | 83 | 94 | 106 | Throw (m) | | 1 | 2 | 3 | | |
| | | 1 | 2 | 3 | 1.8 | 2.4 | 3.4 | 4.0 | 4.3 | 4.9 | 5.2 | 5.5 | 5.8 | 6.1 | 6.7 | 7.3 | |
| | | 2 | 3 | 2.7 | 4.0 | 4.3 | 4.9 | 5.2 | 5.5 | 5.8 | 6.1 | 6.7 | 7.3 | 7.9 | 8.2 | 8.2 | |
| | | 3 | 4.9 | 5.5 | 6.1 | 6.7 | 7.3 | 7.9 | 8.2 | 8.8 | 9.5 | 10.4 | 11.0 | 11.0 | 11.0 | 11.0 | |





Performance Data

SH Square Diffusers

| Nominal Size (mm) | Air Pattern (viewed from neck) | Neck Vel. (m/s) Total Press. (Pa) | 1.5 | 2.0 | 2.5 | 3.0 | 3.5 | 4.0 | 4.5 |
|-------------------|--------------------------------|--------------------------------------|-----|-----|-----|-----|-----|-----|-----|
| | | | 11 | 19 | 29 | 42 | 57 | 75 | 94 |

| 375 | X | SH1 |  | Total l/s | | 221 | | 295 | | 369 | | 443 | | 516 | | 590 | | 664 | | | | | |
|-----|---|------|---|--------------|--|------|------|------|------|------|------|------|------|------|------|------|-----|------|------|------|------|---|---|
| | | | | NC | | 11 | | 19 | | 25 | | 29 | | 33 | | 37 | | 40 | | | | | |
| | | | | Side | | A | B | A | B | A | B | A | B | A | B | A | B | A | B | | | | |
| 375 | X | SH1 |  | l/s per side | | 221 | 295 | 369 | 443 | 516 | 590 | 664 | | | | | | | | | | | |
| | | | | Throw (m) | | 1 | 2 | 3 | 1 | 2 | 3 | 1 | 2 | 3 | 1 | 2 | 3 | 1 | 2 | 3 | 1 | 2 | 3 |
| | | | | 1 | | 5.8 | 7.0 | 7.9 | 8.5 | 9.1 | 9.8 | 10.4 | 11.3 | 12.2 | 12.8 | | | | | | | | |
| | | | | 2 | | 7.3 | 8.5 | 9.5 | 10.4 | 11.3 | 12.2 | 12.8 | 13.7 | 14.9 | 16.2 | | | | | | | | |
| | | | | 3 | | 10.4 | 12.2 | 13.7 | 14.9 | 16.2 | 17.4 | 18.3 | | | | | | | | | | | |
| 375 | X | SH2 |  | l/s per side | | 110 | 148 | 185 | 221 | 258 | 295 | 332 | | | | | | | | | | | |
| | | | | Throw (m) | | 1 | 2 | 3 | 1 | 2 | 3 | 1 | 2 | 3 | 1 | 2 | 3 | 1 | 2 | 3 | 1 | 2 | 3 |
| | | | | 1 | | 2.7 | 3.7 | 4.6 | 5.8 | 6.7 | 7.3 | 7.9 | 8.5 | 9.1 | 9.8 | | | | | | | | |
| | | | | 2 | | 4.3 | 5.8 | 7.0 | 7.9 | 8.5 | 9.1 | 9.8 | 10.1 | 11.0 | 11.9 | | | | | | | | |
| | | | | 3 | | 7.9 | 9.1 | 10.1 | 11.0 | 11.9 | 12.8 | 13.7 | | | | | | | | | | | |
| 375 | X | SHD2 |  | l/s per side | | 110 | 148 | 185 | 221 | 258 | 295 | 332 | | | | | | | | | | | |
| | | | | Throw (m) | | 1 | 2 | 3 | 1 | 2 | 3 | 1 | 2 | 3 | 1 | 2 | 3 | 1 | 2 | 3 | 1 | 2 | 3 |
| | | | | 1 | | 2.7 | 3.7 | 4.6 | 5.8 | 6.7 | 7.3 | 7.9 | 8.5 | 9.1 | 9.8 | | | | | | | | |
| | | | | 2 | | 4.3 | 5.8 | 7.0 | 7.9 | 8.5 | 9.1 | 9.8 | 10.1 | 11.0 | 11.9 | | | | | | | | |
| | | | | 3 | | 7.9 | 9.1 | 10.1 | 11.0 | 11.9 | 12.8 | 13.7 | | | | | | | | | | | |
| 375 | X | SH3 |  | l/s per side | | 83 | 55 | 110 | 74 | 138 | 92 | 166 | 110 | 194 | 129 | 221 | 148 | 249 | 166 | | | | |
| | | | | Throw (m) | | 1 | 2 | 3 | 1 | 2 | 3 | 1 | 2 | 3 | 1 | 2 | 3 | 1 | 2 | 3 | 1 | 2 | 3 |
| | | | | 1 | | 2.7 | 2.4 | 3.7 | 3.4 | 4.6 | 4.0 | 5.5 | 4.9 | 6.1 | 5.2 | 6.4 | 5.5 | 7.0 | 6.1 | 8.5 | 7.3 | | |
| | | | | 2 | | 4.0 | 3.7 | 5.5 | 4.9 | 6.4 | 5.5 | 7.0 | 6.1 | 7.3 | 6.4 | 7.9 | 7.0 | 9.1 | 8.1 | 11.3 | 10.4 | | |
| | | | | 3 | | 7.0 | 6.1 | 7.9 | 7.0 | 8.8 | 7.6 | 9.8 | 8.5 | 10.7 | 9.1 | 11.3 | 9.8 | 12.2 | 11.3 | 13.7 | 12.8 | | |
| 375 | X | SH4 |  | l/s per side | | 55 | 74 | 92 | 110 | 129 | 148 | 166 | | | | | | | | | | | |
| | | | | Throw (m) | | 1 | 2 | 3 | 1 | 2 | 3 | 1 | 2 | 3 | 1 | 2 | 3 | 1 | 2 | 3 | 1 | 2 | 3 |
| | | | | 1 | | 2.4 | 3.4 | 4.0 | 4.9 | 5.2 | 5.5 | 6.1 | 6.4 | 7.0 | 7.3 | | | | | | | | |
| | | | | 2 | | 3.7 | 4.9 | 5.5 | 6.1 | 6.4 | 7.0 | 7.3 | 7.9 | 8.1 | 8.5 | | | | | | | | |
| | | | | 3 | | 6.1 | 7.0 | 7.6 | 8.5 | 9.1 | 9.8 | 10.4 | 11.0 | 11.9 | 12.8 | | | | | | | | |

| 450 | X | SH1 |  | Total l/s | | 319 | | 425 | | 531 | | 637 | | 743 | | 850 | | 956 | | | | | |
|-----|---|------|---|--------------|--|------|------|------|------|------|------|------|------|------|------|------|------|------|------|------|------|---|---|
| | | | | NC | | 12 | | 20 | | 26 | | 31 | | 35 | | 38 | | 41 | | | | | |
| | | | | Side | | A | B | A | B | A | B | A | B | A | B | A | B | A | B | | | | |
| 450 | X | SH1 |  | l/s per side | | 319 | 425 | 531 | 637 | 743 | 850 | 956 | | | | | | | | | | | |
| | | | | Throw (m) | | 1 | 2 | 3 | 1 | 2 | 3 | 1 | 2 | 3 | 1 | 2 | 3 | 1 | 2 | 3 | 1 | 2 | 3 |
| | | | | 1 | | 6.7 | 8.2 | 9.5 | 10.4 | 11.6 | 12.5 | 13.7 | 14.6 | 15.5 | 16.5 | | | | | | | | |
| | | | | 2 | | 8.8 | 10.4 | 11.6 | 12.5 | 13.7 | 14.6 | 15.5 | 16.5 | 17.4 | 18.3 | | | | | | | | |
| | | | | 3 | | 12.5 | 14.6 | 16.5 | 18.0 | 19.2 | 20.7 | 22.0 | | | | | | | | | | | |
| 450 | X | SH2 |  | l/s per side | | 160 | 212 | 266 | 319 | 372 | 425 | 478 | | | | | | | | | | | |
| | | | | Throw (m) | | 1 | 2 | 3 | 1 | 2 | 3 | 1 | 2 | 3 | 1 | 2 | 3 | 1 | 2 | 3 | 1 | 2 | 3 |
| | | | | 1 | | 3.4 | 4.6 | 5.8 | 6.7 | 7.9 | 8.8 | 9.5 | 10.1 | 11.0 | 11.9 | | | | | | | | |
| | | | | 2 | | 5.2 | 6.7 | 8.5 | 9.5 | 10.1 | 11.0 | 11.9 | 12.8 | 13.7 | 14.6 | | | | | | | | |
| | | | | 3 | | 9.5 | 11.0 | 12.2 | 13.4 | 14.3 | 15.5 | 16.5 | | | | | | | | | | | |
| 450 | X | SHD2 |  | l/s per side | | 160 | 212 | 266 | 319 | 372 | 425 | 478 | | | | | | | | | | | |
| | | | | Throw (m) | | 1 | 2 | 3 | 1 | 2 | 3 | 1 | 2 | 3 | 1 | 2 | 3 | 1 | 2 | 3 | 1 | 2 | 3 |
| | | | | 1 | | 3.4 | 4.6 | 5.8 | 6.7 | 7.9 | 8.8 | 9.5 | 10.1 | 11.0 | 11.9 | | | | | | | | |
| | | | | 2 | | 5.2 | 6.7 | 8.5 | 9.5 | 10.1 | 11.0 | 11.9 | 12.8 | 13.7 | 14.6 | | | | | | | | |
| | | | | 3 | | 9.5 | 11.0 | 12.2 | 13.4 | 14.3 | 15.5 | 16.5 | | | | | | | | | | | |
| 450 | X | SH3 |  | l/s per side | | 119 | 80 | 160 | 106 | 199 | 133 | 239 | 160 | 279 | 186 | 319 | 212 | 358 | 239 | | | | |
| | | | | Throw (m) | | 1 | 2 | 3 | 1 | 2 | 3 | 1 | 2 | 3 | 1 | 2 | 3 | 1 | 2 | 3 | 1 | 2 | 3 |
| | | | | 1 | | 3.4 | 2.7 | 4.3 | 4.0 | 5.5 | 4.9 | 6.7 | 5.8 | 7.3 | 6.4 | 7.9 | 6.7 | 9.1 | 7.9 | 10.4 | 9.1 | | |
| | | | | 2 | | 4.9 | 4.3 | 6.7 | 5.8 | 8.2 | 7.3 | 9.8 | 8.5 | 11.3 | 10.1 | 12.8 | 11.0 | 15.5 | 13.7 | 17.4 | 15.5 | | |
| | | | | 3 | | 8.2 | 7.3 | 9.8 | 8.2 | 12.2 | 10.4 | 15.5 | 13.7 | 18.3 | 16.5 | 20.7 | 18.3 | 22.0 | 20.7 | 22.0 | 20.7 | | |
| 450 | X | SH4 |  | l/s per side | | 80 | 106 | 133 | 160 | 186 | 212 | 239 | | | | | | | | | | | |
| | | | | Throw (m) | | 1 | 2 | 3 | 1 | 2 | 3 | 1 | 2 | 3 | 1 | 2 | 3 | 1 | 2 | 3 | 1 | 2 | 3 |
| | | | | 1 | | 2.7 | 4.0 | 4.9 | 5.8 | 6.4 | 7.3 | 7.9 | 8.2 | 8.5 | | | | | | | | | |
| | | | | 2 | | 4.3 | 5.8 | 6.7 | 7.3 | 7.9 | 8.2 | 8.5 | 9.1 | 9.8 | | | | | | | | | |
| | | | | 3 | | 7.3 | 8.2 | 9.5 | 10.4 | 11.0 | 11.9 | 12.8 | 13.7 | 14.6 | | | | | | | | | |

| 525 | X | SH1 |  | Total l/s | | 434 | | 578 | | 723 | | 868 | | 1012 | | 1156 | | 1301 | | | | | |
|-----|---|------|---|--------------|--|------|------|------|------|------|------|------|------|------|------|------|-----|------|------|------|------|---|---|
| | | | | NC | | 13 | | 21 | | 27 | | 32 | | 36 | | 39 | | 42 | | | | | |
| | | | | Side | | A | B | A | B | A | B | A | B | A | B | A | B | A | B | | | | |
| 525 | X | SH1 |  | l/s per side | | 434 | 578 | 723 | 868 | 1012 | 1156 | 1301 | | | | | | | | | | | |
| | | | | Throw (m) | | 1 | 2 | 3 | 1 | 2 | 3 | 1 | 2 | 3 | 1 | 2 | 3 | 1 | 2 | 3 | 1 | 2 | 3 |
| | | | | 1 | | 7.9 | 9.8 | 11.0 | 11.9 | 13.4 | 14.6 | 15.9 | 17.1 | 18.0 | 19.2 | | | | | | | | |
| | | | | 2 | | 10.4 | 11.9 | 13.4 | 14.6 | 15.9 | 17.1 | 18.0 | 19.2 | 20.7 | 22.0 | | | | | | | | |
| | | | | 3 | | 14.6 | 17.1 | 19.2 | 21.0 | 22.6 | 24.1 | 25.6 | | | | | | | | | | | |
| 525 | X | SH2 |  | l/s per side | | 217 | 289 | 362 | 434 | 506 | 578 | 650 | | | | | | | | | | | |
| | | | | Throw (m) | | 1 | 2 | 3 | 1 | 2 | 3 | 1 | 2 | 3 | 1 | 2 | 3 | 1 | 2 | 3 | 1 | 2 | 3 |
| | | | | 1 | | 4.0 | 5.2 | 6.7 | 7.9 | 9.5 | 10.4 | 11.9 | 12.8 | 14.6 | | | | | | | | | |
| | | | | 2 | | 5.8 | 7.9 | 10.1 | 11.0 | 11.9 | 12.8 | 13.7 | 14.6 | 15.5 | | | | | | | | | |
| | | | | 3 | | 11.0 | 12.8 | 14.3 | 15.5 | 16.8 | 18.0 | 19.2 | | | | | | | | | | | |
| 525 | X | SHD2 |  | l/s per side | | 217 | 289 | 362 | 434 | 506 | 578 | 650 | | | | | | | | | | | |
| | | | | Throw (m) | | 1 | 2 | 3 | 1 | 2 | 3 | 1 | 2 | 3 | 1 | 2 | 3 | 1 | 2 | 3 | 1 | 2 | 3 |
| | | | | 1 | | 4.0 | 5.2 | 6.7 | 7.9 | 9.5 | 10.4 | 11.9 | 12.8 | 14.6 | | | | | | | | | |
| | | | | 2 | | 5.8 | 7.9 | 10.1 | 11.0 | 11.9 | 12.8 | 13.7 | 14.6 | 15.5 | | | | | | | | | |
| | | | | 3 | | 11.0 | 12.8 | 14.3 | 15.5 | 16.8 | 18.0 | 19.2 | | | | | | | | | | | |
| 525 | X | SH3 |  | l/s per side | | 163 | 109 | 217 | 144 | 271 | 181 | 325 | 217 | 379 | 253 | 434 | 289 | 488 | 325 | | | | |
| | | | | Throw (m) | | 1 | 2 | 3 | 1 | 2 | 3 | 1 | 2 | 3 | 1 | 2 | 3 | 1 | 2 | 3 | 1 | 2 | 3 |
| | | | | 1 | | 3.7 | 3.4 | 5.2 | 4.6 | 6.4 | 5.8 | 7.6 | 6.7 | 8.5 | 7.3 | 9.1 | 7.9 | 11.3 | 9.8 | 11.9 | 10.4 | | |
| | | | | 2 | | 5.8 | 5.2 | 7.6 | 6.7 | 8.8 | 7.6 | 9.8 | 8.5 | 10.4 | 9.1 | 11.3 | 9.8 | 13.7 | 12.8 | 15.5 | 14.6 | | |
| | | | | | | | | | | | | | | | | | | | | | | | |

Performance Data

SH Square Diffusers

| Nominal Size (mm) | Air Pattern (viewed from neck) | Neck Vel. (m/s) Total Press. (Pa) | 1.5 | 2.0 | 2.5 | 3.0 | 3.5 | 4.0 | 4.5 |
|-------------------|--------------------------------|--------------------------------------|-----|-----|-----|-----|-----|-----|-----|
| | | | 11 | 19 | 29 | 42 | 57 | 75 | 94 |

| 600 | X | 600 | Total l/s NC Side | 566 14 | | 755 22 | | 944 28 | | 1 133 32 | | 1 322 36 | | 1 510 40 | | 1 699 43 | | | | | | | | | | | | | | | | | | | |
|------|---|---------------------------|-------------------------|-----------|------|-----------|-------|-----------|-------|-------------|------|-------------|------|-------------|------|-------------|------|------|------|------|------|------|------|------|------|------|------|------|------|------|------|------|------|------|------|
| | | | | A | B | A | B | A | B | A | B | A | B | A | B | A | B | | | | | | | | | | | | | | | | | | |
| SH1 | | l/s per side Throw (m) | 1 | 566 | 755 | 944 | 1 133 | 1 322 | 1 510 | 1 699 | 1 | 9.1 | 11.3 | 12.5 | 13.7 | 14.9 | 15.9 | 16.8 | | | | | | | | | | | | | | | | | |
| | | | 2 | 11.9 | 13.7 | 15.2 | 16.8 | 18.3 | 19.5 | 20.7 | 21.9 | 2 | 11.9 | 13.7 | 15.2 | 16.8 | 18.3 | 19.5 | 20.7 | | | | | | | | | | | | | | | | |
| | | | 3 | 16.8 | 19.5 | 22.0 | 23.8 | 25.9 | 27.7 | 29.3 | 30.9 | 3 | 16.8 | 19.5 | 22.0 | 23.8 | 25.9 | 27.7 | 29.3 | | | | | | | | | | | | | | | | |
| SH2 | | l/s per side Throw (m) | 1 | 283 | 378 | 472 | 566 | 661 | 755 | 850 | 1 | 4.6 | 6.1 | 7.6 | 9.1 | 10.7 | 11.9 | 12.5 | | | | | | | | | | | | | | | | | |
| | | | 2 | 6.7 | 9.1 | 11.6 | 12.5 | 13.7 | 14.6 | 15.5 | 16.4 | 2 | 6.7 | 9.1 | 11.6 | 12.5 | 13.7 | 14.6 | 15.5 | | | | | | | | | | | | | | | | |
| | | | 3 | 12.5 | 14.6 | 16.5 | 18.0 | 19.2 | 20.7 | 22.0 | 23.2 | 3 | 12.5 | 14.6 | 16.5 | 18.0 | 19.2 | 20.7 | 22.0 | | | | | | | | | | | | | | | | |
| SHD2 | | l/s per side Throw (m) | 1 | 283 | 378 | 472 | 566 | 661 | 755 | 850 | 1 | 4.6 | 6.1 | 7.6 | 9.1 | 10.7 | 11.9 | 12.5 | | | | | | | | | | | | | | | | | |
| | | | 2 | 6.7 | 9.1 | 11.6 | 12.5 | 13.7 | 14.6 | 15.5 | 16.4 | 2 | 6.7 | 9.1 | 11.6 | 12.5 | 13.7 | 14.6 | 15.5 | | | | | | | | | | | | | | | | |
| | | | 3 | 12.5 | 14.6 | 16.5 | 18.0 | 19.2 | 20.7 | 22.0 | 23.2 | 3 | 12.5 | 14.6 | 16.5 | 18.0 | 19.2 | 20.7 | 22.0 | | | | | | | | | | | | | | | | |
| SH3 | | l/s per side Throw (m) | 1 | 212 | 142 | 283 | 189 | 354 | 236 | 425 | 283 | 496 | 330 | 566 | 378 | 637 | 425 | 1 | 4.3 | 4.0 | 5.8 | 5.2 | 7.3 | 6.7 | 8.8 | 7.9 | 11.0 | 9.8 | 11.9 | 10.4 | 9.1 | 11.0 | 9.8 | | |
| | | | 2 | 6.7 | 5.8 | 8.8 | 7.9 | 10.1 | 8.8 | 11.0 | 9.8 | 11.9 | 10.4 | 12.8 | 11.3 | 13.7 | 11.9 | 10.4 | 12.8 | 11.3 | 13.7 | 11.9 | 10.4 | 12.8 | 11.3 | 13.7 | 11.9 | 10.4 | 12.8 | 11.3 | 13.7 | 11.9 | 10.4 | 12.8 | |
| | | | 3 | 11.0 | 9.8 | 12.8 | 11.3 | 14.3 | 12.5 | 15.9 | 13.7 | 17.1 | 14.9 | 18.3 | 15.9 | 18.3 | 15.9 | 19.5 | 16.8 | 3 | 11.0 | 9.8 | 12.8 | 11.3 | 14.3 | 12.5 | 15.9 | 13.7 | 17.1 | 14.9 | 18.3 | 15.9 | 19.5 | 16.8 | |
| SH4 | | l/s per side Throw (m) | 1 | 142 | 189 | 236 | 283 | 330 | 378 | 425 | 1 | 4.0 | 5.2 | 6.7 | 7.9 | 8.5 | 9.1 | 9.8 | 1 | 4.0 | 5.2 | 6.7 | 7.9 | 8.5 | 9.1 | 9.8 | 10.4 | 11.3 | 11.9 | 12.5 | 13.7 | 14.9 | 15.9 | | |
| | | | 2 | 5.8 | 7.9 | 8.8 | 9.8 | 10.4 | 11.3 | 11.9 | 12.5 | 13.7 | 14.9 | 15.9 | 16.4 | 17.1 | 17.7 | 18.3 | 18.9 | 2 | 5.8 | 7.9 | 8.8 | 9.8 | 10.4 | 11.3 | 11.9 | 12.5 | 13.7 | 14.9 | 15.9 | 16.4 | 17.1 | 17.7 | 18.3 |
| | | | 3 | 9.8 | 11.3 | 12.5 | 13.7 | 14.9 | 15.9 | 16.4 | 17.1 | 17.7 | 18.3 | 18.9 | 19.5 | 20.1 | 20.7 | 21.3 | 21.9 | 22.5 | 3 | 9.8 | 11.3 | 12.5 | 13.7 | 14.9 | 15.9 | 16.4 | 17.1 | 17.7 | 18.3 | 18.9 | 19.5 | 20.1 | 20.7 |



| 750 | X | 750 | Total l/s NC Side | 885 16 | | 1 180 23 | | 1 475 29 | | 1 770 34 | | 2 650 38 | | 2 360 41 | | 2 655 44 | | | | | | | | | | | | | | | | |
|------|---|---------------------------|-------------------------|-----------|-------|-------------|-------|-------------|-------|-------------|------|-------------|------|-------------|------|-------------|------|------|------|------|------|------|------|------|------|------|------|------|------|------|------|------|
| | | | | A | B | A | B | A | B | A | B | A | B | A | B | A | B | | | | | | | | | | | | | | | |
| SH1 | | l/s per side Throw (m) | 1 | 885 | 1 180 | 1 475 | 1 770 | 2 065 | 2 360 | 2 655 | 1 | 11.6 | 14.0 | 15.9 | 17.4 | 18.6 | 19.8 | 21.0 | | | | | | | | | | | | | | |
| | | | 2 | 14.9 | 17.4 | 19.2 | 21.0 | 22.9 | 24.4 | 25.9 | 27.4 | 2 | 14.9 | 17.4 | 19.2 | 21.0 | 22.9 | 24.4 | 25.9 | | | | | | | | | | | | | |
| | | | 3 | 21.0 | 24.4 | 27.4 | 29.9 | 32.3 | 34.8 | 36.6 | 38.1 | 3 | 21.0 | 24.4 | 27.4 | 29.9 | 32.3 | 34.8 | 36.6 | | | | | | | | | | | | | |
| SH2 | | l/s per side Throw (m) | 1 | 443 | 590 | 738 | 885 | 1 033 | 1 180 | 1 328 | 1 | 5.8 | 7.6 | 9.5 | 11.6 | 13.4 | 14.9 | 15.9 | | | | | | | | | | | | | | |
| | | | 2 | 8.5 | 11.6 | 14.3 | 15.9 | 17.1 | 18.3 | 19.5 | 20.7 | 2 | 8.5 | 11.6 | 14.3 | 15.9 | 17.1 | 18.3 | 19.5 | | | | | | | | | | | | | |
| | | | 3 | 15.9 | 18.3 | 20.4 | 22.3 | 24.1 | 25.9 | 27.4 | 29.0 | 3 | 15.9 | 18.3 | 20.4 | 22.3 | 24.1 | 25.9 | 27.4 | | | | | | | | | | | | | |
| SHD2 | | l/s per side Throw (m) | 1 | 443 | 590 | 738 | 885 | 1 033 | 1 180 | 1 328 | 1 | 5.8 | 7.6 | 9.5 | 11.6 | 13.4 | 14.9 | 15.9 | | | | | | | | | | | | | | |
| | | | 2 | 8.5 | 11.6 | 14.3 | 15.9 | 17.1 | 18.3 | 19.5 | 20.7 | 2 | 8.5 | 11.6 | 14.3 | 15.9 | 17.1 | 18.3 | 19.5 | | | | | | | | | | | | | |
| | | | 3 | 15.9 | 18.3 | 20.4 | 22.3 | 24.1 | 25.9 | 27.4 | 29.0 | 3 | 15.9 | 18.3 | 20.4 | 22.3 | 24.1 | 25.9 | 27.4 | | | | | | | | | | | | | |
| SH3 | | l/s per side Throw (m) | 1 | 332 | 221 | 443 | 295 | 553 | 369 | 664 | 443 | 775 | 516 | 885 | 590 | 995 | 664 | 1 | 5.5 | 4.9 | 7.3 | 6.7 | 9.1 | 8.2 | 11.0 | 9.8 | 12.8 | 11.0 | 14.0 | 12.2 | 14.9 | 12.2 |
| | | | 2 | 8.2 | 7.3 | 11.0 | 9.8 | 12.8 | 11.0 | 14.0 | 12.2 | 14.9 | 13.1 | 16.2 | 14.0 | 17.1 | 14.9 | 12.2 | 14.9 | 13.1 | 16.2 | 14.0 | 17.1 | 14.9 | 12.2 | 14.9 | 13.1 | 16.2 | 14.0 | 17.1 | 14.9 | |
| | | | 3 | 14.0 | 12.2 | 16.2 | 14.0 | 18.0 | 15.5 | 19.8 | 17.1 | 21.3 | 18.6 | 22.9 | 19.8 | 24.4 | 21.0 | 21.0 | 18.6 | 22.9 | 19.8 | 24.4 | 21.0 | 21.0 | 18.6 | 22.9 | 19.8 | 24.4 | 21.0 | 21.0 | 18.6 | 22.9 |
| SH4 | | l/s per side Throw (m) | 1 | 221 | 295 | 369 | 443 | 516 | 590 | 664 | 1 | 4.9 | 6.7 | 8.2 | 9.8 | 10.7 | 11.3 | 12.2 | | | | | | | | | | | | | | |
| | | | 2 | 7.3 | 9.8 | 11.0 | 12.2 | 13.1 | 14.0 | 14.9 | 15.9 | 2 | 7.3 | 9.8 | 11.0 | 12.2 | 13.1 | 14.0 | 14.9 | | | | | | | | | | | | | |
| | | | 3 | 12.2 | 14.0 | 15.5 | 17.1 | 18.6 | 19.8 | 21.0 | 22.5 | 3 | 12.2 | 14.0 | 15.5 | 17.1 | 18.6 | 19.8 | 21.0 | | | | | | | | | | | | | |



| 900 | X | 900 | Total l/s NC Side | 1 274 17 | | 1 699 24 | | 2 124 30 | | 2 549 35 | | 2 974 39 | | 3 398 43 | | 3 823 46 | | | | | | | | | | | | | | | | |
|------|---|---------------------------|-------------------------|-------------|-------|-------------|-------|-------------|-------|-------------|------|-------------|------|-------------|------|-------------|------|------|------|-----|------|------|------|------|------|------|------|------|------|------|------|------|
| | | | | A | B | A | B | A | B | A | B | A | B | A | B | A | B | | | | | | | | | | | | | | | |
| SH1 | | l/s per side Throw (m) | 1 | 1 274 | 1 699 | 2 124 | 2 549 | 2 974 | 3 398 | 3 823 | 1 | 13.7 | 16.8 | 18.9 | 20.7 | 22.3 | 23.8 | 25.3 | | | | | | | | | | | | | | |
| | | | 2 | 18.0 | 20.7 | 23.2 | 25.3 | 27.4 | 29.3 | 31.1 | 32.9 | 2 | 18.0 | 20.7 | 23.2 | 25.3 | 27.4 | 29.3 | 31.1 | | | | | | | | | | | | | |
| | | | 3 | 25.3 | 29.3 | 32.9 | 36.0 | 38.7 | 41.5 | 44.2 | 46.9 | 3 | 25.3 | 29.3 | 32.9 | 36.0 | 38.7 | 41.5 | 44.2 | | | | | | | | | | | | | |
| SH2 | | l/s per side Throw (m) | 1 | 637 | 850 | 1 062 | 1 274 | 1 487 | 1 699 | 1 912 | 1 | 6.7 | 9.1 | 11.6 | 13.7 | 16.2 | 18.0 | 18.9 | | | | | | | | | | | | | | |
| | | | 2 | 10.4 | 13.7 | 17.4 | 18.9 | 20.4 | 22.0 | 23.2 | 24.4 | 2 | 10.4 | 13.7 | 17.4 | 18.9 | 20.4 | 22.0 | 23.2 | | | | | | | | | | | | | |
| | | | 3 | 18.9 | 22.0 | 24.7 | 26.8 | 29.0 | 31.1 | 32.9 | 34.9 | 3 | 18.9 | 22.0 | 24.7 | 26.8 | 29.0 | 31.1 | 32.9 | | | | | | | | | | | | | |
| SHD2 | | l/s per side Throw (m) | 1 | 637 | 850 | 1 062 | 1 274 | 1 487 | 1 699 | 1 912 | 1 | 6.7 | 9.1 | 11.6 | 13.7 | 16.2 | 18.0 | 18.9 | | | | | | | | | | | | | | |
| | | | 2 | 10.4 | 13.7 | 17.4 | 18.9 | 20.4 | 22.0 | 23.2 | 24.4 | 2 | 10.4 | 13.7 | 17.4 | 18.9 | 20.4 | 22.0 | 23.2 | | | | | | | | | | | | | |
| | | | 3 | 18.9 | 22.0 | 24.7 | 26.8 | 29.0 | 31.1 | 32.9 | 34.9 | 3 | 18.9 | 22.0 | 24.7 | 26.8 | 29.0 | 31.1 | 32.9 | | | | | | | | | | | | | |
| SH3 | | l/s per side Throw (m) | 1 | 478 | 319 | 637 | 425 | 797 | 531 | 956 | 637 | 1 115 | 743 | 1 274 | 850 | 1 434 | 956 | 1 | 6.7 | 5.8 | 8.8 | 7.9 | 11.0 | 10.1 | 13.4 | 11.9 | 16.8 | 14.6 | 18.0 | 15.9 | 19.5 | 16.8 |
| | | | 2 | 10.1 | 8.8 | 13.4 | 11.9 | 15.2 | 13.4 | 16.8 | 14.6 | 18.0 | 15.9 | 19.5 | 16.8 | 20.4 | 18.0 | 20.4 | 18.0 | 2 | 10.1 | 8.8 | 13.4 | 11.9 | 15.2 | 13.4 | 16.8 | 14.6 | 18.0 | 15.9 | 19.5 | 16.8 |
| | | | 3 | 16.8 | 14.6 | 19.5 | 16.8 | 21.6 | 18.9 | 23.8 | 20.7 | 25.6 | 22.3 | 27.4 | 23.8 | 29.3 | 25.3 | 29.3 | 25.3 | 3 | 16.8 | 14.6 | 19.5 | 16.8 | 21.6 | 18.9 | 23.8 | 20.7 | 25.6 | 22.3 | 27.4 | 23.8 |
| SH4 | | l/s per side Throw (m) | 1 | 319 | 425 | 531 | 637 | 743 | 850 | 956 | 1 | 5.8 | 7.9 | 10.1 | 11.9 | 12.8 | 13.7 | 14.6 | | | | | | | | | | | | | | |
| | | | 2 | 8.8 | 11.9 | 13.4 | 14.6 | 15.9 | 16.8 | 17.7 | 18.6 | 2 | 8.8 | 11.9 | 13.4 | 14.6 | 15.9 | 16.8 | 17.7 | | | | | | | | | | | | | |
| | | | 3 | 14.6 | 16.8 | 18.9 | 20.7 | 22.3 | 23.8 | 25.3 | 26.8 | 3 | 14.6 | 16.8 | 18.9 | 20.7 | 22.3 | 23.8 | 25.3 | | | | | | | | | | | | | |

Performance Data

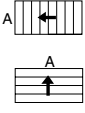
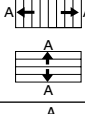
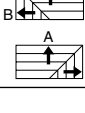
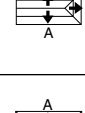
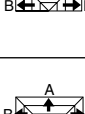
SH Rectangular Diffusers

| Nominal Size (mm) | Air Pattern (viewed from neck) | Neck Vel. (m/s) Total Press. (Pa) | 1.5 | 2.0 | 2.5 | 3.0 | 3.5 | 4.0 | 4.5 |
|-------------------|--------------------------------|--------------------------------------|-----|-----|-----|-----|-----|-----|-----|
| | | | 11 | 19 | 29 | 42 | 57 | 75 | 94 |

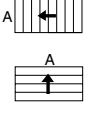
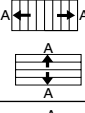
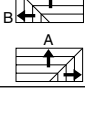
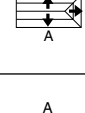
| | | Total l/s NC Side | 53 < 10 | | 71 14 | | 89 20 | | 106 25 | | 124 29 | | 142 32 | | 160 35 | |
|--|---|---------------------------------------|------------|-----|----------|-----|----------|-----|-----------|-----|-----------|-----|-----------|-----|-----------|-----|
| | | | A | B | A | B | A | B | A | B | A | B | A | B | A | B |
| 150 X 225 | SH1  | l/s per side Throw (m) 1 2 3 | 53 | 71 | 89 | 106 | 124 | 142 | 160 | 3.0 | 3.7 | 4.0 | 4.3 | 4.9 | 5.2 | 5.5 |
| | 3.7 | | 4.3 | 4.9 | 5.5 | 5.8 | 6.4 | 6.7 | 7.3 | 7.6 | 8.2 | 8.8 | 9.5 | | | |
| | 5.5 | | 6.4 | 7.0 | 7.6 | 8.2 | 8.8 | 9.5 | | | | | | | | |
| | SH2  | l/s per side Throw (m) 1 2 3 | 26 | 35 | 44 | 53 | 62 | 71 | 80 | 1.5 | 2.1 | 2.7 | 3.4 | 4.0 | 4.3 | 4.6 |
| | 2.4 | | 3.4 | 4.0 | 4.6 | 4.9 | 5.2 | 5.5 | 5.8 | 6.4 | 6.7 | 7.3 | 7.9 | | | |
| | 4.6 | | 5.2 | 5.8 | 6.4 | 6.7 | 7.3 | 7.9 | | | | | | | | |
| SHD2  | l/s per side Throw (m) 1 2 3 | 35 | 17 | 47 | 24 | 59 | 29 | 71 | 35 | 83 | 41 | 94 | 47 | 106 | 53 | |
| 2.1 | | 1.2 | 2.7 | 1.5 | 3.0 | 2.1 | 3.4 | 2.4 | 3.7 | 3.0 | 4.0 | 3.4 | 4.3 | 3.4 | | |
| 3.0 | | 1.8 | 3.4 | 2.4 | 3.7 | 3.0 | 4.3 | 3.4 | 4.6 | 3.7 | 4.9 | 4.0 | 5.2 | 4.3 | | |
| SH3S  | l/s per side Throw (m) 1 2 3 | 22 | 9 | 30 | 12 | 37 | 15 | 44 | 18 | 51 | 21 | 59 | 24 | 67 | 26 | |
| 1.8 | | 1.2 | 2.4 | 1.5 | 3.0 | 2.1 | 3.4 | 2.4 | 4.0 | 3.0 | 4.3 | 3.4 | 4.6 | 3.7 | | |
| 2.7 | | 1.8 | 3.4 | 2.4 | 3.7 | 2.7 | 4.0 | 3.0 | 4.3 | 3.4 | 4.6 | 3.7 | 4.9 | 3.7 | | |
| SH3L  | l/s per side Throw (m) 1 2 3 | 20 | 17 | 26 | 22 | 33 | 28 | 40 | 33 | 46 | 39 | 53 | 44 | 60 | 50 | |
| 1.8 | | 1.2 | 2.4 | 1.5 | 3.0 | 2.1 | 3.7 | 2.4 | 4.0 | 3.0 | 4.3 | 3.4 | 4.3 | 3.4 | | |
| 2.7 | | 1.8 | 3.7 | 2.4 | 4.0 | 3.0 | 4.3 | 3.4 | 4.9 | 3.7 | 5.2 | 4.0 | 5.5 | 4.3 | | |
| SH4R  | l/s per side Throw (m) 1 2 3 | 17 | 9 | 24 | 12 | 29 | 15 | 35 | 18 | 41 | 21 | 47 | 24 | 53 | 26 | |
| 1.8 | | 1.2 | 2.4 | 1.5 | 3.0 | 2.1 | 3.4 | 2.4 | 4.0 | 3.0 | 4.3 | 3.4 | 4.6 | 3.7 | | |
| 2.7 | | 1.8 | 3.4 | 2.4 | 3.7 | 2.7 | 4.0 | 3.0 | 4.3 | 3.4 | 4.6 | 3.7 | 4.9 | 3.7 | | |



| | | Total l/s NC Side | 71 < 10 | | 94 15 | | 118 21 | | 142 26 | | 165 30 | | 189 33 | | 212 36 | |
|--|---|---------------------------------------|------------|-----|----------|-----|-----------|------|-----------|-----|-----------|------|-----------|-----|-----------|---|
| | | | A | B | A | B | A | B | A | B | A | B | A | B | A | B |
| 150 X 300 | SH1  | l/s per side Throw (m) 1 2 3 | 71 | 94 | 118 | 142 | 165 | 189 | 212 | 3.7 | 4.3 | 4.6 | 5.2 | 5.8 | 6.4 | |
| | 4.3 | | 5.2 | 5.8 | 6.4 | 6.7 | 7.3 | 7.9 | 8.5 | 9.1 | 9.8 | 10.4 | 11.0 | | | |
| | 6.4 | | 7.3 | 8.2 | 8.8 | 9.8 | 10.4 | 11.0 | | | | | | | | |
| | SH2  | l/s per side Throw (m) 1 2 3 | 35 | 47 | 59 | 71 | 83 | 94 | 106 | 1.8 | 2.4 | 3.4 | 4.0 | 4.9 | 5.2 | |
| | 2.7 | | 4.0 | 4.6 | 5.2 | 5.5 | 6.1 | 6.7 | 7.3 | 7.9 | 8.5 | 9.1 | | | | |
| | 5.2 | | 6.1 | 6.7 | 7.3 | 7.9 | 8.5 | 9.1 | | | | | | | | |
| SHD2  | l/s per side Throw (m) 1 2 3 | 53 | 18 | 71 | 24 | 89 | 30 | 106 | 35 | 124 | 42 | 142 | 47 | 160 | 53 | |
| 2.4 | | 1.5 | 3.0 | 1.8 | 3.7 | 2.4 | 4.0 | 3.0 | 4.3 | 3.4 | 4.6 | 3.7 | 4.9 | 4.0 | | |
| 3.4 | | 2.1 | 4.0 | 3.0 | 4.6 | 3.7 | 4.9 | 4.0 | 5.2 | 4.3 | 5.5 | 4.6 | 6.1 | 4.9 | | |
| SH3S  | l/s per side Throw (m) 1 2 3 | 31 | 9 | 42 | 12 | 52 | 15 | 62 | 18 | 72 | 21 | 83 | 24 | 93 | 26 | |
| 2.1 | | 1.5 | 2.7 | 1.8 | 3.4 | 2.4 | 3.7 | 2.7 | 4.0 | 3.0 | 4.3 | 3.4 | 4.6 | 3.7 | | |
| 3.4 | | 2.1 | 3.7 | 2.7 | 4.3 | 3.4 | 4.6 | 3.7 | 4.9 | 4.0 | 5.5 | 4.3 | 5.8 | 4.3 | | |
| SH3L  | l/s per side Throw (m) 1 2 3 | 35 | 18 | 47 | 24 | 59 | 30 | 71 | 35 | 83 | 42 | 94 | 47 | 106 | 53 | |
| 2.7 | | 1.5 | 3.7 | 1.8 | 4.0 | 2.4 | 4.6 | 3.0 | 4.9 | 3.4 | 5.2 | 3.7 | 5.5 | 4.0 | | |
| 4.0 | | 2.1 | 4.6 | 3.0 | 4.9 | 3.7 | 5.5 | 4.0 | 6.1 | 4.3 | 6.4 | 4.6 | 6.7 | 4.9 | | |
| SH4R  | l/s per side Throw (m) 1 2 3 | 26 | 9 | 35 | 12 | 44 | 15 | 53 | 18 | 62 | 21 | 71 | 24 | 80 | 26 | |
| 2.1 | | 1.5 | 2.7 | 1.8 | 3.4 | 2.4 | 3.7 | 2.7 | 4.0 | 3.0 | 4.3 | 3.4 | 4.6 | 3.7 | | |
| 3.4 | | 2.1 | 3.7 | 2.7 | 4.3 | 3.4 | 4.6 | 3.7 | 4.9 | 4.0 | 5.5 | 4.3 | 5.8 | 4.3 | | |

Performance Data

SH Rectangular Diffusers

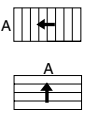
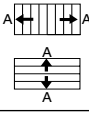
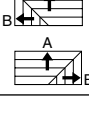
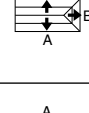
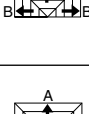
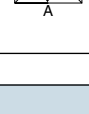
| Nominal Size (mm) | Air Pattern (viewed from neck) | Neck Vel. (m/s) Total Press. (Pa) | 1.5 | 2.0 | 2.5 | 3.0 | 3.5 | 4.0 | 4.5 |
|-------------------|--------------------------------|--------------------------------------|-----|-----|-----|-----|-----|-----|-----|
| | | | 11 | 19 | 29 | 42 | 57 | 75 | 94 |

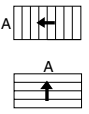
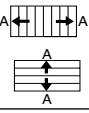
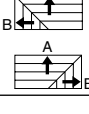
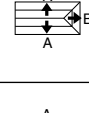
| | | Total l/s NC Side | 89 < 10 | | 118 16 | | 148 22 | | 177 26 | | 207 30 | | 236 34 | | 266 37 | |
|--|---|---------------------------------------|------------|-----|-----------|-----|-----------|-----|-----------|------|-----------|------|-----------|------|-----------|---|
| | | | A | B | A | B | A | B | A | B | A | B | A | B | A | B |
| 150 X 375 | SH1  | l/s per side Throw (m) 1 2 3 | 89 | | 118 | | 148 | | 177 | | 207 | | 236 | | 266 | |
| | 4.0 | | | 4.6 | | 5.2 | | 5.8 | | 6.1 | | 6.7 | | 7.0 | | |
| | 4.9 | | | 5.8 | | 6.4 | | 7.0 | | 7.6 | | 8.2 | | 8.5 | | |
| | 7.0 | | 8.2 | | 9.1 | | 10.1 | | 10.7 | | 11.6 | | 12.2 | | | |
| | SH2  | l/s per side Throw (m) 1 2 3 | 44 | | 59 | | 74 | | 89 | | 103 | | 118 | | 133 | |
| | 2.1 | | | 2.7 | | 3.7 | | 4.3 | | 5.2 | | 5.5 | | 5.8 | | |
| 3.4 | | | 4.3 | | 5.2 | | 5.8 | | 6.1 | | 6.7 | | 7.0 | | | |
| 5.8 | | 6.7 | | 7.6 | | 8.2 | | 8.8 | | 9.5 | | 10.1 | | 10.1 | | |
| SHD2  | l/s per side Throw (m) 1 2 3 | 71 | 18 | 94 | 24 | 118 | 30 | 142 | 35 | 165 | 42 | 189 | 47 | 212 | 53 | |
| 2.7 | | 1.5 | 3.7 | 2.1 | 4.0 | 2.7 | 4.6 | 3.4 | 4.9 | 4.0 | 5.2 | 4.3 | 5.5 | 4.6 | | |
| 3.7 | | 2.4 | 4.6 | 3.4 | 4.9 | 4.0 | 5.5 | 4.6 | 5.8 | 4.9 | 6.4 | 5.2 | 6.7 | 5.5 | | |
| 5.5 | 4.6 | 6.4 | 5.2 | 7.0 | 5.8 | 7.6 | 6.4 | 8.5 | 7.0 | 9.1 | 7.3 | 9.5 | 7.9 | 9.5 | 7.9 | |
| SH3S  | l/s per side Throw (m) 1 2 3 | 40 | 9 | 53 | 12 | 67 | 15 | 80 | 18 | 93 | 21 | 106 | 24 | 119 | 26 | |
| 2.4 | | 1.5 | 3.4 | 2.1 | 4.0 | 2.7 | 4.3 | 3.4 | 4.6 | 3.4 | 4.9 | 3.7 | 5.2 | 4.0 | | |
| 3.7 | | 2.4 | 4.3 | 3.4 | 4.6 | 3.7 | 5.2 | 4.0 | 5.5 | 4.3 | 6.1 | 4.6 | 6.4 | 4.9 | | |
| 5.2 | 4.0 | 6.1 | 4.6 | 6.7 | 5.2 | 7.3 | 5.8 | 7.9 | 6.1 | 8.5 | 6.7 | 9.1 | 7.0 | 9.1 | 7.0 | |
| SH3L  | l/s per side Throw (m) 1 2 3 | 53 | 18 | 71 | 24 | 89 | 30 | 106 | 35 | 124 | 42 | 142 | 47 | 160 | 53 | |
| 3.7 | | 1.5 | 4.3 | 2.1 | 4.6 | 2.7 | 5.2 | 3.4 | 5.5 | 4.0 | 5.8 | 4.3 | 6.4 | 4.6 | | |
| 4.3 | | 2.4 | 5.2 | 3.4 | 5.8 | 4.0 | 6.4 | 4.6 | 6.7 | 4.9 | 7.3 | 5.2 | 7.6 | 5.5 | | |
| 6.4 | 4.6 | 7.3 | 5.2 | 8.2 | 5.8 | 8.8 | 6.4 | 9.8 | 7.0 | 10.4 | 7.3 | 11.0 | 7.9 | 11.0 | 7.9 | |
| SH4R  | l/s per side Throw (m) 1 2 3 | 35 | 9 | 47 | 12 | 59 | 15 | 71 | 18 | 83 | 21 | 94 | 24 | 106 | 26 | |
| 2.4 | | 1.5 | 3.4 | 2.1 | 4.0 | 2.7 | 4.3 | 3.4 | 4.6 | 3.4 | 4.9 | 3.7 | 5.2 | 4.0 | | |
| 3.7 | | 2.4 | 4.3 | 3.4 | 4.6 | 3.7 | 5.2 | 4.0 | 5.5 | 4.3 | 6.1 | 4.6 | 6.4 | 4.9 | | |
| 5.2 | 4.0 | 6.1 | 4.6 | 6.7 | 5.2 | 7.3 | 5.8 | 7.9 | 6.1 | 8.5 | 6.7 | 9.1 | 7.0 | 9.1 | 7.0 | |

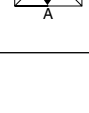
| | | Total l/s NC Side | 106 < 10 | | 142 16 | | 177 22 | | 212 27 | | 248 31 | | 283 34 | | 319 38 | |
|--|---|---------------------------------------|-------------|-----|-----------|-----|-----------|------|-----------|------|-----------|------|-----------|------|-----------|---|
| | | | A | B | A | B | A | B | A | B | A | B | A | B | A | B |
| 150 X 450 | SH1  | l/s per side Throw (m) 1 2 3 | 106 | | 142 | | 177 | | 212 | | 248 | | 283 | | 319 | |
| | 4.3 | | | 5.2 | | 5.8 | | 6.4 | | 6.7 | | 7.3 | | 7.6 | | |
| | 5.5 | | | 6.4 | | 7.0 | | 7.6 | | 8.2 | | 8.8 | | 9.5 | | |
| | 7.6 | | 8.8 | | 10.1 | | 11.0 | | 11.9 | | 12.8 | | 13.4 | | 13.4 | |
| | SH2  | l/s per side Throw (m) 1 2 3 | 53 | | 71 | | 89 | | 106 | | 124 | | 142 | | 160 | |
| | 2.4 | | | 3.0 | | 4.0 | | 4.9 | | 5.5 | | 6.1 | | 6.4 | | |
| 3.7 | | | 4.9 | | 5.8 | | 6.4 | | 6.7 | | 7.3 | | 7.9 | | | |
| 6.4 | | 7.3 | | 8.2 | | 9.1 | | 9.8 | | 10.4 | | 11.0 | | 11.0 | | |
| SHD2  | l/s per side Throw (m) 1 2 3 | 88 | 18 | 118 | 24 | 147 | 30 | 177 | 35 | 206 | 42 | 236 | 47 | 265 | 53 | |
| 3.0 | | 1.8 | 4.0 | 2.4 | 4.6 | 3.0 | 4.9 | 3.7 | 5.2 | 4.3 | 5.5 | 4.6 | 6.1 | 4.9 | | |
| 4.3 | | 2.7 | 4.9 | 3.7 | 5.5 | 4.6 | 6.1 | 4.9 | 6.4 | 5.2 | 7.0 | 5.8 | 7.3 | 6.1 | | |
| 6.1 | 4.9 | 7.0 | 5.8 | 7.6 | 6.4 | 8.5 | 7.0 | 9.1 | 7.6 | 9.8 | 8.2 | 10.4 | 8.5 | 10.4 | 8.5 | |
| SH3S  | l/s per side Throw (m) 1 2 3 | 49 | 9 | 65 | 12 | 81 | 15 | 97 | 17 | 113 | 21 | 130 | 24 | 146 | 26 | |
| 2.7 | | 1.8 | 3.7 | 2.4 | 4.3 | 3.0 | 4.6 | 3.7 | 4.9 | 4.0 | 5.5 | 4.3 | 5.8 | 4.3 | | |
| 4.0 | | 2.7 | 4.6 | 3.7 | 5.2 | 4.0 | 5.8 | 4.3 | 6.1 | 4.9 | 6.7 | 5.2 | 7.0 | 5.5 | | |
| 5.8 | 4.3 | 6.7 | 5.2 | 7.3 | 5.8 | 8.2 | 6.4 | 8.8 | 6.7 | 9.5 | 7.3 | 10.1 | 7.6 | 10.1 | 7.6 | |
| SH3L  | l/s per side Throw (m) 1 2 3 | 71 | 18 | 94 | 24 | 118 | 30 | 142 | 35 | 165 | 42 | 189 | 47 | 212 | 53 | |
| 4.0 | | 1.8 | 4.6 | 2.4 | 5.2 | 3.0 | 5.5 | 3.7 | 6.1 | 4.3 | 6.4 | 4.6 | 7.0 | 4.9 | | |
| 4.9 | | 2.7 | 5.5 | 3.7 | 6.4 | 4.6 | 7.0 | 4.9 | 7.3 | 5.2 | 7.9 | 5.8 | 8.5 | 6.1 | | |
| 7.0 | 4.9 | 7.9 | 5.8 | 8.8 | 6.4 | 9.8 | 7.0 | 10.7 | 7.6 | 11.3 | 8.2 | 11.9 | 8.5 | 11.9 | 8.5 | |
| SH4R  | l/s per side Throw (m) 1 2 3 | 44 | 9 | 59 | 12 | 74 | 15 | 89 | 17 | 103 | 21 | 118 | 24 | 133 | 26 | |
| 2.7 | | 1.8 | 3.7 | 2.4 | 4.3 | 3.0 | 4.6 | 3.7 | 4.9 | 4.0 | 5.5 | 4.3 | 5.8 | 4.3 | | |
| 4.0 | | 2.7 | 4.6 | 3.7 | 5.2 | 4.0 | 5.8 | 4.3 | 6.1 | 4.9 | 6.7 | 5.2 | 7.0 | 5.5 | | |
| 5.8 | 4.3 | 6.7 | 5.2 | 7.3 | 5.8 | 8.2 | 6.4 | 8.8 | 6.7 | 9.5 | 7.3 | 10.1 | 7.6 | 10.1 | 7.6 | |

Performance Data

SH Rectangular Diffusers

| Nominal Size (mm) | Air Pattern (viewed from neck) | Neck Vel. (m/s) Total Press. (Pa) | 1.5 | 2.0 | 2.5 | 3.0 | 3.5 | 4.0 | 4.5 |
|-------------------|--------------------------------|--------------------------------------|-----|-----|-----|-----|-----|-----|-----|
| | | | 11 | 19 | 29 | 42 | 57 | 75 | 94 |

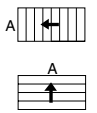
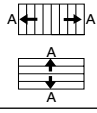
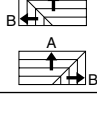
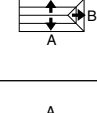
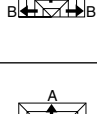
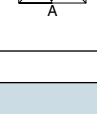
| | | Total l/s NC Side | 124 < 10 | | 165 17 | | 207 23 | | 248 27 | | 289 31 | | 330 35 | | 372 38 | | | |
|-------------------------|---|---------------------------------------|--------------------------|--------------------------|---------------------------|---------------------------|---------------------------|---------------------------|----------------------------|-------------------------|---------------------------|-------------------------|---------------------------|-------------------------|---------------------------|-------------------------|--|--|
| | | | A | B | A | B | A | B | A | B | A | B | A | B | A | B | | |
| 150 X 525 | SH1  | l/s per side Throw (m) 1 2 3 | 124 4.9 5.8 8.2 | 165 5.5 6.7 9.8 | 207 6.1 7.6 10.7 | 248 6.7 8.2 11.9 | 289 7.3 9.1 12.8 | 330 7.9 9.8 13.7 | 372 8.2 10.4 14.6 | | | | | | | | | |
| | SH2  | l/s per side Throw (m) 1 2 3 | 62 2.4 4.0 6.7 | 83 3.4 5.2 7.9 | 103 4.3 6.1 8.8 | 124 5.2 6.7 9.8 | 144 6.1 7.3 10.7 | 165 6.4 7.9 11.3 | 186 6.7 8.5 11.9 | | | | | | | | | |
| | SHD2  | l/s per side Throw (m) 1 2 3 | 106 3.4 4.6 6.4 | 18 1.8 3.0 5.2 | 142 4.3 5.2 7.6 | 24 2.7 4.0 6.1 | 177 4.9 5.8 8.5 | 30 3.4 4.9 7.0 | 212 5.2 6.4 9.1 | 35 4.0 5.2 7.6 | 248 5.8 7.0 10.1 | 42 4.6 5.8 8.2 | 283 6.1 7.6 10.7 | 47 4.9 6.1 8.8 | 319 6.4 7.9 11.3 | 53 5.2 6.4 9.5 | | |
| | SH3S  | l/s per side Throw (m) 1 2 3 | 58 2.7 4.3 6.1 | 9 1.8 3.0 4.9 | 76 4.0 4.9 7.0 | 12 2.4 4.0 5.5 | 96 4.6 5.5 7.9 | 15 3.4 4.3 6.1 | 115 4.9 6.1 8.8 | 17 4.0 4.9 6.7 | 134 5.5 6.7 9.5 | 20 4.3 5.2 7.3 | 153 5.8 7.0 10.1 | 24 4.6 5.5 7.9 | 172 6.1 7.6 10.7 | 26 4.9 5.8 8.2 | | |
| | SH3L  | l/s per side Throw (m) 1 2 3 | 88 4.3 5.2 7.3 | 18 1.8 3.0 5.2 | 118 4.9 6.1 8.5 | 24 2.7 4.0 6.1 | 147 5.5 6.7 9.8 | 30 3.4 4.9 7.0 | 177 6.1 7.3 10.7 | 35 4.0 5.2 7.6 | 206 6.4 7.9 11.3 | 42 4.6 5.8 8.2 | 236 7.0 8.5 12.2 | 47 4.9 6.1 8.8 | 265 7.3 9.1 13.1 | 53 5.2 6.4 9.5 | | |
| | SH4R  | l/s per side Throw (m) 1 2 3 | 53 2.7 4.3 6.1 | 9 1.8 3.0 4.9 | 71 4.0 4.9 7.0 | 12 2.4 4.0 5.5 | 89 4.6 5.5 7.9 | 15 3.4 4.3 6.1 | 106 4.9 6.1 8.8 | 17 4.0 4.9 6.7 | 124 5.5 6.7 9.5 | 20 4.3 5.2 7.3 | 142 5.8 7.0 10.1 | 24 4.6 5.5 7.9 | 160 6.1 7.6 10.7 | 26 4.9 5.8 8.2 | | |

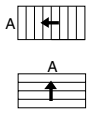
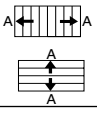
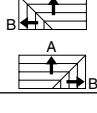
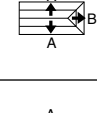
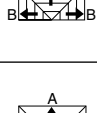
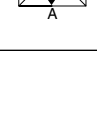
| | | Total l/s NC Side | 142 10 | | 189 17 | | 236 23 | | 283 28 | | 330 32 | | 378 35 | | 425 38 | | | |
|-------------------------|---|---------------------------------------|--------------------------|---------------------------|---------------------------|---------------------------|---------------------------|----------------------------|----------------------------|-------------------------|---------------------------|-------------------------|---------------------------|-------------------------|---------------------------|--------------------------|--|--|
| | | | A | B | A | B | A | B | A | B | A | B | A | B | A | B | | |
| 150 X 600 | SH1  | l/s per side Throw (m) 1 2 3 | 142 5.2 6.4 8.8 | 189 5.8 7.3 10.4 | 236 6.7 8.2 11.6 | 283 7.3 8.8 12.8 | 330 7.9 9.8 13.7 | 378 8.5 10.4 14.6 | 425 8.8 11.0 15.5 | | | | | | | | | |
| | SH2  | l/s per side Throw (m) 1 2 3 | 71 2.7 4.3 7.3 | 94 3.7 5.5 8.5 | 118 4.6 6.7 9.5 | 142 5.5 7.3 10.4 | 165 6.4 7.9 11.3 | 189 7.0 8.5 12.2 | 212 7.3 9.1 12.8 | | | | | | | | | |
| | SHD2  | l/s per side Throw (m) 1 2 3 | 124 3.7 4.9 7.0 | 18 2.1 3.0 5.8 | 165 4.6 5.5 7.9 | 24 2.7 4.3 6.7 | 207 5.2 6.4 9.1 | 30 3.7 5.2 7.3 | 248 5.5 7.0 9.8 | 35 4.3 5.8 8.2 | 289 6.1 7.6 10.7 | 42 4.9 6.1 8.8 | 330 6.4 7.9 11.3 | 47 5.5 6.7 9.5 | 372 7.0 8.5 12.2 | 53 5.8 7.0 10.1 | | |
| | SH3S  | l/s per side Throw (m) 1 2 3 | 67 3.0 4.6 6.7 | 9 2.1 3.0 5.2 | 89 4.3 5.5 7.6 | 12 2.7 4.3 5.8 | 111 4.9 6.1 8.5 | 15 3.4 4.6 6.7 | 133 5.5 6.7 9.5 | 18 4.3 5.2 7.3 | 155 5.8 7.0 10.1 | 21 4.6 5.5 7.9 | 177 6.1 7.6 11.0 | 24 4.9 5.8 8.5 | 199 6.7 8.2 11.6 | 27 5.2 6.4 8.8 | | |
| | SH3L  | l/s per side Throw (m) 1 2 3 | 106 4.6 5.5 7.9 | 18 2.1 3.0 5.8 | 142 5.2 6.4 9.1 | 24 2.7 4.3 6.7 | 177 5.8 7.3 10.4 | 30 3.7 5.2 7.3 | 212 6.4 7.9 11.3 | 35 4.3 5.8 8.2 | 248 7.0 8.5 12.2 | 42 4.9 6.1 8.8 | 283 7.6 9.1 13.1 | 47 5.5 6.7 9.5 | 319 7.9 9.8 14.0 | 53 5.8 7.0 10.1 | | |
| | SH4R  | l/s per side Throw (m) 1 2 3 | 62 3.0 4.6 6.7 | 9 2.1 3.0 5.2 | 83 4.3 5.5 7.6 | 12 2.7 4.3 5.8 | 103 4.9 6.1 8.5 | 15 3.4 4.6 6.7 | 124 5.5 6.7 9.5 | 18 4.3 5.2 7.3 | 145 5.8 7.0 10.1 | 21 4.6 5.5 7.9 | 165 6.1 7.6 11.0 | 24 4.9 5.8 8.5 | 186 6.7 8.2 11.6 | 27 5.2 6.4 8.8 | | |

Performance Data

SH Rectangular Diffusers

| Nominal Size (mm) | Air Pattern (viewed from neck) | Neck Vel. (m/s) | 1.5 | 2.0 | 2.5 | 3.0 | 3.5 | 4.0 | 4.5 |
|-------------------|--------------------------------|-------------------|-----|-----|-----|-----|-----|-----|-----|
| | | Total Press. (Pa) | 11 | 19 | 29 | 42 | 57 | 75 | 94 |

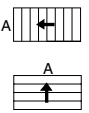
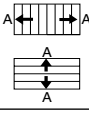
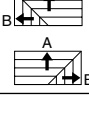
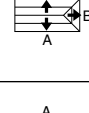
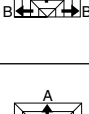
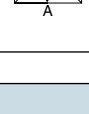
| 150 X 750 | SH1  | Total l/s NC Side | 177 | | 236 | | 295 | | 354 | | 413 | | 472 | | 531 | |
|-----------------|---|---------------------|------|-----|------|-----|------|-----|------|-----|------|-----|------|------|------|------|
| | | | 10 | | 18 | | 24 | | 29 | | 33 | | 36 | | 39 | |
| | | | A | B | A | B | A | B | A | B | A | B | A | B | A | B |
| | | l/s per side | 177 | | 236 | | 295 | | 354 | | 413 | | 472 | | 531 | |
| | | Throw (m) 1 | 5.8 | | 6.7 | | 7.3 | | 8.2 | | 8.8 | | 9.5 | | 10.1 | |
| | | 2 | 7.0 | | 8.2 | | 9.1 | | 10.1 | | 10.7 | | 11.6 | | 12.2 | |
| | | 3 | 10.1 | | 11.6 | | 12.8 | | 14.3 | | 15.2 | | 16.5 | | 17.4 | |
| | SH2  | l/s per side | 89 | | 118 | | 148 | | 177 | | 207 | | 236 | | 266 | |
| | | Throw (m) 1 | 3.0 | | 4.3 | | 5.2 | | 6.4 | | 7.3 | | 7.6 | | 8.2 | |
| | | 2 | 4.6 | | 6.4 | | 7.6 | | 8.2 | | 8.8 | | 9.5 | | 10.1 | |
| | | 3 | 8.2 | | 9.5 | | 10.7 | | 11.6 | | 12.5 | | 13.4 | | 14.3 | |
| | SHD2  | l/s per side | 160 | 18 | 212 | 24 | 266 | 30 | 319 | 35 | 372 | 42 | 425 | 47 | 478 | 53 |
| | | Throw (m) 1 | 4.0 | 2.4 | 5.2 | 3.0 | 5.8 | 4.0 | 6.4 | 4.9 | 6.7 | 5.5 | 7.3 | 6.1 | 7.6 | 6.4 |
| | | 2 | 5.5 | 3.7 | 6.4 | 4.9 | 7.0 | 5.8 | 7.6 | 6.4 | 8.5 | 7.0 | 9.1 | 7.3 | 9.5 | 7.9 |
| | | 3 | 7.6 | 6.4 | 9.1 | 7.3 | 10.1 | 8.2 | 11.0 | 9.1 | 11.9 | 9.8 | 12.8 | 10.7 | 13.7 | 11.3 |
| | SH3S  | l/s per side | 84 | 9 | 112 | 12 | 140 | 15 | 168 | 18 | 196 | 21 | 224 | 24 | 252 | 26 |
| | | Throw (m) 1 | 3.4 | 2.4 | 4.6 | 3.0 | 5.5 | 4.0 | 6.1 | 4.6 | 6.4 | 4.9 | 7.0 | 5.5 | 7.3 | 5.8 |
| | | 2 | 5.2 | 3.7 | 6.1 | 4.6 | 6.7 | 5.2 | 7.3 | 5.8 | 7.9 | 6.1 | 8.5 | 6.7 | 9.1 | 7.0 |
| | | 3 | 7.3 | 5.8 | 8.5 | 6.7 | 9.5 | 7.3 | 10.7 | 8.2 | 11.3 | 8.8 | 12.2 | 9.5 | 12.8 | 10.1 |
| | SH3L  | l/s per side | 142 | 18 | 189 | 24 | 236 | 30 | 283 | 35 | 330 | 42 | 378 | 47 | 425 | 53 |
| | | Throw (m) 1 | 4.9 | 2.4 | 5.8 | 3.0 | 6.7 | 4.0 | 7.3 | 4.9 | 7.9 | 5.5 | 8.5 | 6.1 | 8.8 | 6.4 |
| | | 2 | 6.4 | 3.7 | 7.3 | 4.9 | 8.2 | 5.8 | 8.8 | 6.4 | 9.8 | 7.0 | 10.4 | 7.3 | 11.0 | 7.9 |
| | | 3 | 8.8 | 6.4 | 10.4 | 7.3 | 11.6 | 8.2 | 12.8 | 9.1 | 13.7 | 9.8 | 14.6 | 10.7 | 15.5 | 11.3 |
| | SH4R  | l/s per side | 80 | 9 | 106 | 12 | 133 | 15 | 160 | 18 | 186 | 21 | 212 | 24 | 239 | 26 |
| | | Throw (m) 1 | 3.4 | 2.4 | 4.6 | 3.0 | 5.5 | 4.0 | 6.1 | 4.6 | 6.4 | 4.9 | 7.0 | 5.5 | 7.3 | 5.8 |
| | | 2 | 5.2 | 3.7 | 6.1 | 4.6 | 6.7 | 5.2 | 7.3 | 5.8 | 7.9 | 6.1 | 8.5 | 6.7 | 9.1 | 7.0 |
| | | 3 | 7.3 | 5.8 | 8.5 | 6.7 | 9.5 | 7.3 | 10.7 | 8.2 | 11.3 | 8.8 | 12.2 | 9.5 | 12.8 | 10.1 |

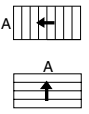
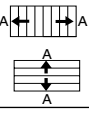
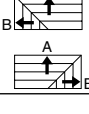
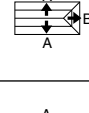
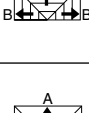
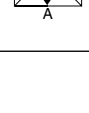
| 225 X 300 | SH1  | Total l/s NC Side | 106 | | 142 | | 177 | | 212 | | 248 | | 283 | | 319 | |
|-----------------|---|---------------------|------|-----|-----|-----|------|-----|------|-----|------|-----|------|-----|------|-----|
| | | | < 10 | | 16 | | 22 | | 27 | | 31 | | 34 | | 38 | |
| | | | A | B | A | B | A | B | A | B | A | B | A | B | A | B |
| | | l/s per side | 106 | | 142 | | 177 | | 212 | | 248 | | 283 | | 319 | |
| | | Throw (m) 1 | 4.3 | | 5.2 | | 5.8 | | 6.4 | | 6.7 | | 7.3 | | 7.6 | |
| | | 2 | 5.5 | | 6.4 | | 7.0 | | 7.6 | | 8.2 | | 8.8 | | 9.5 | |
| | | 3 | 7.6 | | 8.8 | | 10.1 | | 11.0 | | 11.9 | | 12.8 | | 13.4 | |
| | SH2  | l/s per side | 53 | | 71 | | 89 | | 106 | | 124 | | 142 | | 160 | |
| | | Throw (m) 1 | 2.4 | | 3.0 | | 4.0 | | 4.9 | | 5.5 | | 6.1 | | 6.4 | |
| | | 2 | 3.7 | | 4.9 | | 5.8 | | 6.4 | | 6.7 | | 7.3 | | 7.9 | |
| | | 3 | 6.4 | | 7.3 | | 8.2 | | 9.1 | | 9.8 | | 10.4 | | 11.0 | |
| | SHD2  | l/s per side | 67 | 40 | 89 | 53 | 110 | 67 | 133 | 80 | 155 | 93 | 177 | 106 | 199 | 119 |
| | | Throw (m) 1 | 3.0 | 1.8 | 4.0 | 2.4 | 4.6 | 3.0 | 4.9 | 3.7 | 5.2 | 4.3 | 5.5 | 4.6 | 6.1 | 4.9 |
| | | 2 | 4.3 | 2.7 | 4.9 | 3.7 | 5.5 | 4.6 | 6.1 | 4.9 | 6.4 | 5.2 | 7.0 | 5.8 | 7.3 | 6.1 |
| | | 3 | 6.1 | 4.9 | 7.0 | 5.8 | 7.6 | 6.4 | 8.5 | 7.0 | 9.1 | 7.6 | 9.8 | 8.2 | 10.4 | 8.5 |
| | SH3S  | l/s per side | 43 | 20 | 58 | 26 | 72 | 34 | 86 | 40 | 101 | 47 | 115 | 53 | 129 | 60 |
| | | Throw (m) 1 | 2.7 | 1.8 | 3.7 | 2.4 | 4.3 | 3.0 | 4.6 | 3.7 | 4.9 | 4.0 | 5.5 | 4.3 | 5.8 | 4.3 |
| | | 2 | 4.0 | 2.7 | 4.6 | 3.7 | 5.2 | 4.0 | 5.8 | 4.3 | 6.1 | 4.9 | 6.7 | 5.2 | 7.0 | 5.5 |
| | | 3 | 5.8 | 4.3 | 6.7 | 5.2 | 7.3 | 5.8 | 8.2 | 6.4 | 8.8 | 6.7 | 9.5 | 7.3 | 10.1 | 7.6 |
| | SH3L  | l/s per side | 40 | 26 | 54 | 33 | 66 | 45 | 80 | 52 | 92 | 64 | 106 | 71 | 129 | 60 |
| | | Throw (m) 1 | 2.4 | 1.8 | 3.4 | 2.4 | 4.3 | 3.0 | 5.2 | 3.7 | 5.5 | 4.3 | 5.8 | 4.6 | 6.4 | 4.9 |
| | | 2 | 4.0 | 2.7 | 5.2 | 3.7 | 5.8 | 4.6 | 6.4 | 4.9 | 6.7 | 5.2 | 7.3 | 5.8 | 7.6 | 6.1 |
| | | 3 | 6.4 | 4.9 | 7.3 | 5.8 | 8.2 | 6.4 | 8.8 | 7.0 | 9.8 | 7.6 | 10.4 | 8.2 | 11.0 | 8.5 |
| | SH4R  | l/s per side | 33 | 20 | 44 | 26 | 55 | 34 | 67 | 40 | 77 | 47 | 89 | 53 | 100 | 60 |
| | | Throw (m) 1 | 2.7 | 1.8 | 3.7 | 2.4 | 4.3 | 3.0 | 4.6 | 3.7 | 4.9 | 4.0 | 5.5 | 4.3 | 5.8 | 4.3 |
| | | 2 | 4.0 | 2.7 | 4.6 | 3.7 | 5.2 | 4.0 | 5.8 | 4.3 | 6.1 | 4.9 | 6.7 | 5.2 | 7.0 | 5.5 |
| | | 3 | 5.8 | 4.3 | 6.7 | 5.2 | 7.3 | 5.8 | 8.2 | 6.4 | 8.8 | 6.7 | 9.5 | 7.3 | 10.1 | 7.6 |

Performance Data

SH Rectangular Diffusers

| Nominal Size (mm) | Air Pattern (viewed from neck) | Neck Vel. (m/s) | 1.5 | 2.0 | 2.5 | 3.0 | 3.5 | 4.0 | 4.5 |
|-------------------|--------------------------------|-------------------|-----|-----|-----|-----|-----|-----|-----|
| | | Total Press. (Pa) | 11 | 19 | 29 | 42 | 57 | 75 | 94 |

| 225 | X | SH1 | Total l/s NC Side | 133 | | 177 | | 221 | | 266 | | 310 | | 354 | | 398 | | | | |
|------|---------------------------|------|---------------------------|-----|-----|-----|-----|-----|-----|-----|-----|-----|------|------|------|------|-----|-----|-----|--|
| | | | | 10 | | 17 | | 23 | | 28 | | 32 | | 35 | | 38 | | | | |
| | | | | A | B | A | B | A | B | A | B | A | B | A | B | A | B | | | |
| 375 | X | SH2 | l/s per side Throw (m) | 1 | 67 | 89 | 110 | 133 | 155 | 177 | 199 | | | | | | | | | |
| | | | | 2 | 2.7 | 3.7 | 4.6 | 5.5 | 6.1 | 6.7 | 7.0 | 7.6 | 8.2 | 8.8 | | | | | | |
| | | | | 3 | 4.0 | 5.5 | 6.4 | 7.0 | 7.6 | 8.2 | 8.8 | 9.1 | 10.1 | 11.0 | 11.6 | 12.5 | | | | |
| | | SHD2 | l/s per side Throw (m) | 1 | 93 | 40 | 124 | 53 | 155 | 67 | 186 | 80 | 217 | 93 | 248 | 106 | 279 | 119 | | |
| | | | | 2 | 3.4 | 2.1 | 4.6 | 2.7 | 4.9 | 3.4 | 5.5 | 4.3 | 6.7 | 4.9 | 7.6 | 6.4 | 8.2 | 6.7 | 5.5 | |
| | | | | 3 | 4.6 | 3.0 | 5.5 | 4.3 | 6.1 | 4.9 | 6.7 | 5.5 | 7.3 | 6.1 | 7.6 | 6.4 | 8.2 | 6.7 | 5.5 | |
| SH3S | l/s per side Throw (m) | 1 | 57 | 20 | 75 | 26 | 94 | 33 | 113 | 40 | 132 | 46 | 151 | 53 | 169 | 60 | | | | |
| | | 2 | 3.0 | 1.8 | 4.0 | 2.7 | 4.6 | 3.4 | 5.2 | 4.0 | 5.5 | 4.3 | 6.1 | 4.6 | 6.4 | 4.9 | | | | |
| | | 3 | 4.6 | 3.0 | 5.2 | 4.0 | 5.8 | 4.6 | 6.4 | 4.9 | 7.0 | 5.2 | 7.3 | 5.8 | 7.9 | 6.1 | | | | |
| SH3L | l/s per side Throw (m) | 1 | 55 | 39 | 74 | 52 | 92 | 65 | 111 | 77 | 129 | 91 | 148 | 103 | 166 | 116 | | | | |
| | | 2 | 2.7 | 2.1 | 4.0 | 2.7 | 4.9 | 3.4 | 5.8 | 4.3 | 6.1 | 4.9 | 6.7 | 5.2 | 7.0 | 5.5 | | | | |
| | | 3 | 4.3 | 3.0 | 5.8 | 4.3 | 6.4 | 4.9 | 7.0 | 5.5 | 7.6 | 6.1 | 8.2 | 6.4 | 8.5 | 6.7 | | | | |
| SH4R | l/s per side Throw (m) | 1 | 46 | 20 | 62 | 26 | 77 | 33 | 93 | 40 | 109 | 46 | 124 | 53 | 139 | 60 | | | | |
| | | 2 | 3.0 | 1.8 | 4.0 | 2.7 | 4.6 | 3.4 | 5.2 | 4.0 | 5.5 | 4.3 | 6.1 | 4.6 | 6.4 | 4.9 | | | | |
| | | 3 | 4.6 | 3.0 | 5.2 | 4.0 | 5.8 | 4.6 | 6.4 | 4.9 | 7.0 | 5.2 | 7.3 | 5.8 | 7.9 | 6.1 | | | | |

| 225 | X | SH1 | Total l/s NC Side | 160 | | 212 | | 266 | | 319 | | 372 | | 425 | | 478 | | | | |
|------|---------------------------|------|---------------------------|-----|-----|-----|-----|-----|-----|-----|-----|------|------|------|------|------|------|------|------|--|
| | | | | 10 | | 18 | | 24 | | 28 | | 32 | | 36 | | 39 | | | | |
| | | | | A | B | A | B | A | B | A | B | A | B | A | B | A | B | | | |
| 450 | X | SH2 | l/s per side Throw (m) | 1 | 80 | 106 | 133 | 160 | 186 | 212 | 239 | | 299 | | 358 | | 417 | | | |
| | | | | 2 | 2.7 | 4.0 | 4.9 | 5.8 | 6.7 | 7.0 | 7.9 | 8.5 | 9.1 | 9.5 | 10.4 | 10.7 | 11.6 | 12.5 | 13.4 | |
| | | | | 3 | 4.3 | 5.8 | 7.0 | 7.9 | 8.5 | 9.1 | 9.5 | 10.1 | 11.0 | 11.9 | 12.8 | 13.7 | 14.6 | 15.5 | 16.5 | |
| | | SHD2 | l/s per side Throw (m) | 1 | 119 | 40 | 160 | 53 | 199 | 67 | 239 | 80 | 279 | 93 | 319 | 106 | 358 | 119 | | |
| | | | | 2 | 3.7 | 2.1 | 4.9 | 3.0 | 5.5 | 3.7 | 6.1 | 4.6 | 6.4 | 5.2 | 7.0 | 5.8 | 7.3 | 6.1 | 5.5 | |
| | | | | 3 | 5.2 | 3.4 | 6.1 | 4.6 | 6.7 | 5.5 | 7.3 | 6.1 | 7.9 | 6.4 | 8.5 | 7.0 | 9.1 | 7.3 | 6.7 | |
| SH3S | l/s per side Throw (m) | 1 | 70 | 20 | 93 | 26 | 116 | 33 | 140 | 40 | 163 | 46 | 186 | 53 | 209 | 60 | | | | |
| | | 2 | 3.4 | 2.1 | 4.3 | 3.0 | 5.2 | 3.7 | 5.8 | 4.3 | 6.1 | 4.9 | 6.7 | 5.2 | 7.0 | 5.5 | | | | |
| | | 3 | 4.9 | 3.4 | 5.8 | 4.3 | 6.4 | 4.9 | 7.0 | 5.5 | 7.6 | 5.8 | 8.2 | 6.4 | 8.5 | 6.7 | 5.5 | | | |
| SH3L | l/s per side Throw (m) | 1 | 80 | 40 | 106 | 53 | 133 | 67 | 160 | 80 | 186 | 93 | 212 | 106 | 239 | 119 | | | | |
| | | 2 | 4.3 | 2.1 | 5.5 | 3.0 | 6.1 | 3.7 | 6.7 | 4.6 | 7.3 | 5.2 | 7.9 | 5.8 | 8.2 | 6.1 | 5.5 | | | |
| | | 3 | 5.8 | 3.4 | 6.7 | 4.6 | 7.6 | 5.5 | 8.2 | 6.1 | 9.1 | 6.4 | 9.8 | 7.0 | 10.4 | 7.3 | 6.7 | | | |
| SH4R | l/s per side Throw (m) | 1 | 60 | 20 | 80 | 26 | 100 | 33 | 119 | 40 | 139 | 46 | 160 | 53 | 179 | 60 | | | | |
| | | 2 | 3.4 | 2.1 | 4.3 | 3.0 | 5.2 | 3.7 | 5.8 | 4.3 | 6.1 | 4.9 | 6.7 | 5.2 | 7.0 | 5.5 | | | | |
| | | 3 | 4.9 | 3.4 | 5.8 | 4.3 | 6.4 | 4.9 | 7.0 | 5.5 | 7.6 | 5.8 | 8.2 | 6.4 | 8.5 | 6.7 | 5.5 | | | |

Performance Data

SH Rectangular Diffusers

| Nominal Size (mm) | Air Pattern (viewed from neck) | Neck Vel. (m/s) Total Press. (Pa) | 1.5 11 | 2.0 19 | 2.5 29 | 3.0 42 | 3.5 57 | 4.0 75 | 4.5 94 |
|-------------------|--------------------------------|--------------------------------------|-----------|-----------|-----------|-----------|-----------|-----------|-----------|
|-------------------|--------------------------------|--------------------------------------|-----------|-----------|-----------|-----------|-----------|-----------|-----------|

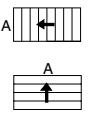
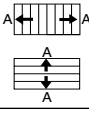
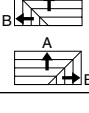
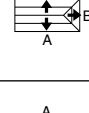
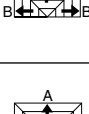
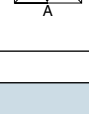
| | | Total l/s NC Side | 186 11 | | 248 18 | | 310 24 | | 372 29 | | 434 33 | | 496 36 | | 557 39 | | |
|-------------------------|--|---------------------------------------|---------------------------|-------------------------|---------------------------|-------------------------|---------------------------|-------------------------|----------------------------|---------------------------|----------------------------|---------------------------|----------------------------|---------------------------|-----------------------------|---------------------------|---------------------------|
| | | | A | B | A | B | A | B | A | B | A | B | A | B | A | B | |
| 225 X 525 | SH1  | l/s per side Throw (m) 1 2 3 | 186 5.8 7.3 10.4 | 40 | 248 6.7 8.2 11.9 | 53 | 310 7.9 9.5 13.4 | 67 | 372 8.2 10.4 14.6 | 80 | 434 9.1 11.0 15.9 | 93 | 496 9.8 11.9 16.8 | 106 | 557 10.4 12.5 18.0 | | |
| | SH2  | l/s per side Throw (m) 1 2 3 | 93 3.0 4.9 8.5 | 40 | 124 4.3 6.4 9.8 | 53 | 155 5.2 7.6 11.0 | 67 | 186 6.4 8.5 11.9 | 80 | 217 7.3 9.1 12.8 | 93 | 248 7.9 9.8 13.7 | 106 | 279 8.5 10.4 14.6 | | |
| | SHD2  | l/s per side Throw (m) 1 2 3 | 146 4.0 5.5 7.9 | 40 2.4 | 194 5.2 6.4 9.1 | 53 3.4 | 244 5.8 7.3 10.4 | 67 4.0 | 310 6.1 8.5 | 372 6.4 7.9 11.3 | 425 4.9 6.4 9.5 | 478 7.0 8.5 12.2 | 531 5.8 7.0 10.1 | 584 7.6 9.1 13.1 | 637 6.1 7.6 10.7 | 690 7.9 9.8 14.0 | 743 6.4 7.9 11.6 |
| | SH3S  | l/s per side Throw (m) 1 2 3 | 83 3.7 5.2 7.6 | 20 2.4 3.7 5.8 | 110 4.9 6.1 8.8 | 26 3.0 4.9 6.7 | 138 5.5 7.0 9.8 | 33 4.0 5.2 7.6 | 166 6.1 7.6 10.7 | 219 4.9 5.8 8.2 | 272 6.7 8.2 11.6 | 325 5.2 6.4 9.1 | 378 7.0 8.8 12.5 | 431 5.5 6.7 9.8 | 484 7.6 9.5 13.1 | 537 5.8 7.3 10.4 | |
| | SH3L  | l/s per side Throw (m) 1 2 3 | 106 5.2 6.4 9.1 | 40 2.4 3.7 6.4 | 142 6.1 7.3 10.7 | 53 3.4 4.9 7.6 | 177 6.7 8.2 11.9 | 67 4.0 6.1 8.5 | 212 7.3 9.1 13.1 | 266 4.9 6.4 9.5 | 319 7.9 9.8 14.0 | 372 5.8 7.0 10.1 | 425 7.9 9.8 14.9 | 478 6.1 7.6 10.7 | 531 9.1 11.3 15.9 | 584 6.4 7.9 11.6 | |
| | SH4R  | l/s per side Throw (m) 1 2 3 | 73 3.7 5.2 7.6 | 20 2.4 3.7 5.8 | 97 4.9 6.1 8.8 | 26 3.0 4.9 6.7 | 122 5.5 7.0 9.8 | 33 4.0 5.2 7.6 | 146 6.1 7.6 10.7 | 199 4.9 5.8 8.2 | 252 6.7 8.2 11.6 | 305 5.2 6.4 9.1 | 358 7.0 8.8 12.5 | 411 5.5 6.7 9.8 | 464 7.6 9.5 13.1 | 517 5.8 7.3 10.4 | |

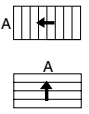
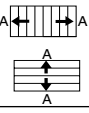
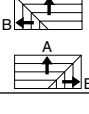
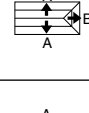
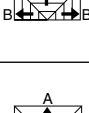
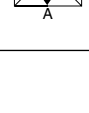
| | | Total l/s NC Side | 212 11 | | 283 19 | | 354 24 | | 425 29 | | 496 33 | | 566 37 | | 637 40 | | |
|-------------------------|--|---------------------------------------|---------------------------|-------------------------|---------------------------|-------------------------|----------------------------|-------------------------|----------------------------|---------------------------|----------------------------|---------------------------|-----------------------------|---------------------------|-----------------------------|----------------------------|---------------------------|
| | | | A | B | A | B | A | B | A | B | A | B | A | B | A | B | |
| 225 X 600 | SH1  | l/s per side Throw (m) 1 2 3 | 212 6.4 7.6 11.0 | 40 | 283 7.3 8.8 12.8 | 53 | 354 8.2 10.1 14.3 | 67 | 425 8.8 11.0 15.5 | 80 | 496 9.8 11.9 16.8 | 93 | 566 10.4 12.8 18.0 | 106 | 637 11.0 13.4 19.2 | | |
| | SH2  | l/s per side Throw (m) 1 2 3 | 106 3.4 5.2 9.1 | 40 | 142 4.6 7.0 10.4 | 53 | 177 5.8 8.2 11.6 | 67 | 212 7.0 9.1 12.8 | 80 | 248 7.9 9.8 13.7 | 93 | 283 8.5 10.4 14.9 | 106 | 319 9.1 11.0 15.9 | | |
| | SHD2  | l/s per side Throw (m) 1 2 3 | 173 4.3 6.1 8.5 | 40 2.4 | 230 5.5 7.0 9.8 | 53 3.4 | 287 6.4 7.6 11.0 | 67 4.3 | 354 6.4 8.5 12.2 | 425 7.0 8.5 12.2 | 496 5.2 7.0 10.1 | 566 7.6 9.1 13.1 | 637 6.1 7.6 10.7 | 708 7.9 9.8 14.0 | 779 6.7 8.2 11.6 | 850 8.5 10.4 14.9 | 921 7.0 8.5 12.2 |
| | SH3S  | l/s per side Throw (m) 1 2 3 | 96 3.7 5.8 8.2 | 20 2.4 4.0 6.4 | 128 5.2 6.7 9.5 | 26 3.4 5.2 7.3 | 160 6.1 7.3 10.7 | 34 4.3 5.8 8.2 | 193 6.7 8.2 11.6 | 246 5.2 6.4 8.8 | 299 7.0 8.8 12.5 | 352 5.5 6.7 9.8 | 405 7.6 9.5 13.4 | 458 5.8 7.3 10.4 | 511 8.2 10.1 14.0 | 564 6.4 7.6 11.0 | |
| | SH3L  | l/s per side Throw (m) 1 2 3 | 133 5.5 7.0 9.8 | 40 2.4 4.0 7.0 | 177 6.4 7.9 11.3 | 53 3.4 5.2 8.2 | 221 7.3 8.8 12.8 | 67 4.3 6.4 9.1 | 266 7.9 9.8 14.0 | 319 5.2 7.0 10.1 | 372 7.9 9.8 14.9 | 425 6.1 7.6 10.7 | 478 8.5 10.7 14.9 | 531 6.1 7.6 10.7 | 584 9.1 11.3 16.2 | 637 6.7 8.2 11.6 | 690 7.0 8.5 12.2 |
| | SH4R  | l/s per side Throw (m) 1 2 3 | 86 3.7 5.8 8.2 | 20 2.4 4.0 6.4 | 115 5.2 6.7 9.5 | 26 3.4 5.2 7.3 | 144 6.1 7.3 10.7 | 33 4.3 5.8 8.2 | 173 6.7 8.2 11.6 | 226 5.2 6.4 8.8 | 279 7.0 8.8 12.5 | 332 5.5 6.7 9.8 | 385 7.6 9.5 13.4 | 438 5.8 7.3 10.4 | 491 8.2 10.1 14.0 | 544 6.4 7.6 11.0 | |

Performance Data

SH Rectangular Diffusers

| Nominal Size (mm) | Air Pattern (viewed from neck) | Neck Vel. (m/s) Total Press. (Pa) | 1.5 | 2.0 | 2.5 | 3.0 | 3.5 | 4.0 | 4.5 |
|-------------------|--------------------------------|--------------------------------------|-----|-----|-----|-----|-----|-----|-----|
| | | | 11 | 19 | 29 | 42 | 57 | 75 | 94 |

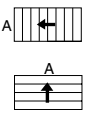
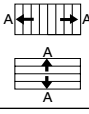
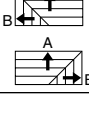
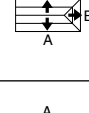
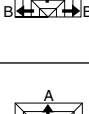
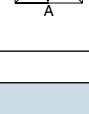
| 225 | X | SH1 |  | Total l/s NC Side | 266 | | 354 | | 443 | | 531 | | 620 | | 708 | | 797 | | | |
|------|---|---------------------------|---|---------------------------|-----|-----|-----|------|------|------|------|------|------|------|------|------|------|------|------|------|
| | | | | | 12 | | 19 | | 25 | | 30 | | 34 | | 37 | | 41 | | | |
| | | | | | A | B | A | B | A | B | A | B | A | B | A | B | A | B | | |
| 750 | X | SH2 |  | l/s per side Throw (m) | 1 | 133 | 177 | 221 | 266 | 310 | 354 | 398 | | | | | | | | |
| | | | | | 2 | 3.7 | 5.2 | 6.4 | 7.6 | 8.8 | 9.5 | 10.1 | 11.0 | 11.6 | 12.5 | 13.1 | 14.3 | 15.5 | 16.5 | 17.7 |
| | | | | | 3 | 5.8 | 7.6 | 9.1 | 10.1 | 11.0 | 11.6 | 12.5 | 13.1 | 14.3 | 15.5 | 16.5 | 17.7 | | | |
| | | SHD2 |  | l/s per side Throw (m) | 1 | 226 | 40 | 301 | 53 | 376 | 67 | 451 | 80 | 527 | 93 | 602 | 106 | 677 | 119 | |
| | | | | | 2 | 4.9 | 2.7 | 6.4 | 4.0 | 7.0 | 4.9 | 7.6 | 5.8 | 8.5 | 7.0 | 9.1 | 7.3 | 9.5 | 7.9 | |
| | | | | | 3 | 6.7 | 4.3 | 7.6 | 5.8 | 8.8 | 7.0 | 9.5 | 7.9 | 10.4 | 8.5 | 11.0 | 9.1 | 11.6 | 9.8 | |
| SH3S |  | l/s per side Throw (m) | 1 | 123 | 20 | 164 | 26 | 205 | 33 | 245 | 40 | 287 | 46 | 328 | 53 | 368 | 60 | | | |
| | | | 2 | 4.3 | 2.7 | 5.8 | 4.0 | 6.7 | 4.9 | 7.3 | 5.8 | 7.9 | 6.1 | 8.5 | 6.7 | 9.1 | 7.0 | | | |
| | | | 3 | 6.4 | 4.3 | 7.3 | 5.8 | 8.2 | 6.4 | 9.1 | 7.0 | 9.8 | 7.6 | 10.7 | 8.2 | 11.3 | 8.5 | | | |
| SH3L |  | l/s per side Throw (m) | 1 | 186 | 40 | 248 | 53 | 310 | 67 | 372 | 80 | 434 | 93 | 496 | 106 | 557 | 119 | | | |
| | | | 2 | 6.1 | 2.7 | 7.3 | 4.0 | 8.2 | 4.9 | 8.8 | 5.8 | 9.8 | 7.0 | 10.4 | 7.3 | 11.0 | 7.9 | | | |
| | | | 3 | 7.6 | 4.3 | 8.8 | 5.8 | 10.1 | 7.0 | 11.0 | 7.9 | 11.9 | 8.5 | 12.8 | 9.1 | 13.4 | 9.8 | | | |
| SH4R |  | l/s per side Throw (m) | 1 | 113 | 20 | 151 | 26 | 188 | 33 | 226 | 40 | 263 | 46 | 301 | 53 | 338 | 60 | | | |
| | | | 2 | 4.3 | 2.7 | 5.8 | 4.0 | 6.7 | 4.9 | 7.3 | 5.8 | 7.9 | 6.1 | 8.5 | 6.7 | 9.1 | 7.0 | | | |
| | | | 3 | 6.4 | 4.3 | 7.3 | 5.8 | 8.2 | 6.4 | 9.1 | 7.0 | 9.8 | 7.6 | 10.7 | 8.2 | 11.3 | 8.5 | | | |

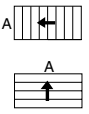
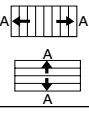
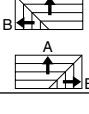
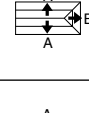
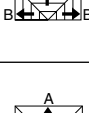
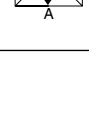
| 225 | X | SH1 |  | Total l/s NC Side | 319 | | 425 | | 531 | | 637 | | 743 | | 850 | | 956 | | | |
|------|---|---------------------------|---|---------------------------|-----|-----|-----|------|------|------|------|------|------|------|------|------|------|------|------|------|
| | | | | | 12 | | 20 | | 26 | | 31 | | 35 | | 38 | | 41 | | | |
| | | | | | A | B | A | B | A | B | A | B | A | B | A | B | A | B | | |
| 900 | X | SH2 |  | l/s per side Throw (m) | 1 | 160 | 212 | 266 | 319 | 372 | 425 | 478 | | | | | | | | |
| | | | | | 2 | 4.3 | 5.5 | 7.0 | 8.5 | 9.8 | 10.4 | 11.0 | 11.9 | 12.8 | 13.7 | 14.3 | 15.9 | 17.1 | 18.3 | 19.2 |
| | | | | | 3 | 6.4 | 8.5 | 10.1 | 11.0 | 11.9 | 12.8 | 13.7 | 14.3 | 15.9 | 17.1 | 18.3 | 19.2 | | | |
| | | SHD2 |  | l/s per side Throw (m) | 1 | 279 | 40 | 372 | 53 | 464 | 67 | 557 | 80 | 650 | 93 | 743 | 106 | 836 | 119 | |
| | | | | | 2 | 5.5 | 3.0 | 7.0 | 4.3 | 7.6 | 5.5 | 8.5 | 6.4 | 9.1 | 7.6 | 9.8 | 8.2 | 10.4 | 8.5 | |
| | | | | | 3 | 7.3 | 4.9 | 8.5 | 6.4 | 9.5 | 7.9 | 10.4 | 8.5 | 11.3 | 9.5 | 12.2 | 10.1 | 12.8 | 10.7 | |
| SH3S |  | l/s per side Throw (m) | 1 | 149 | 20 | 199 | 26 | 249 | 33 | 299 | 40 | 348 | 46 | 398 | 53 | 448 | 60 | | | |
| | | | 2 | 4.6 | 3.0 | 6.4 | 4.3 | 7.3 | 5.2 | 8.2 | 6.4 | 8.8 | 6.7 | 9.5 | 7.3 | 10.1 | 7.6 | | | |
| | | | 3 | 7.0 | 4.9 | 8.2 | 6.4 | 9.1 | 7.0 | 10.1 | 7.6 | 10.7 | 8.2 | 11.6 | 8.8 | 12.2 | 9.5 | | | |
| SH3L |  | l/s per side Throw (m) | 1 | 239 | 40 | 319 | 53 | 398 | 67 | 478 | 80 | 557 | 93 | 637 | 106 | 717 | 119 | | | |
| | | | 2 | 6.7 | 3.0 | 7.9 | 4.3 | 8.8 | 5.5 | 9.8 | 6.4 | 10.7 | 7.6 | 11.3 | 8.2 | 11.9 | 8.5 | | | |
| | | | 3 | 8.5 | 4.9 | 9.8 | 6.4 | 11.0 | 7.9 | 11.9 | 8.5 | 13.1 | 9.5 | 14.0 | 10.1 | 14.6 | 10.7 | | | |
| SH4R |  | l/s per side Throw (m) | 1 | 139 | 20 | 186 | 26 | 232 | 33 | 279 | 40 | 325 | 46 | 372 | 53 | 418 | 60 | | | |
| | | | 2 | 4.6 | 3.0 | 6.4 | 4.3 | 7.3 | 5.2 | 8.2 | 6.4 | 8.8 | 6.7 | 9.5 | 7.3 | 10.1 | 7.6 | | | |
| | | | 3 | 7.0 | 4.9 | 8.2 | 6.4 | 9.1 | 7.0 | 10.1 | 7.6 | 10.7 | 8.2 | 11.6 | 8.8 | 12.2 | 9.5 | | | |

Performance Data

SH Rectangular Diffusers

| Nominal Size (mm) | Air Pattern (viewed from neck) | Neck Vel. (m/s) | 1.5 | 2.0 | 2.5 | 3.0 | 3.5 | 4.0 | 4.5 |
|-------------------|--------------------------------|-------------------|-----|-----|-----|-----|-----|-----|-----|
| | | Total Press. (Pa) | 11 | 19 | 29 | 42 | 57 | 75 | 94 |

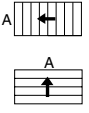
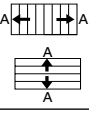
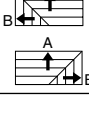
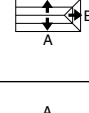
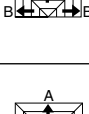
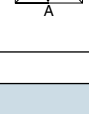
| | | Total l/s NC Side | 177 | | 236 | | 295 | | 354 | | 413 | | 472 | | 531 | |
|-------|--|---------------------------------------|---|---|---|---|---|---|---|---|---|---|--|---|---|--|
| | | | A | B | A | B | A | B | A | B | A | B | A | B | | |
| 300 X | SH1  | l/s per side Throw (m) 1 2 3 | 177 5.8 7.0 10.1 | | 236 6.7 8.2 11.6 | | 295 7.3 9.1 12.8 | | 354 8.2 10.1 14.3 | | 413 8.8 10.7 15.2 | | 472 9.5 11.6 16.5 | | 531 10.1 12.2 17.4 | |
| | SH2  | l/s per side Throw (m) 1 2 3 | 89 3.0 4.6 8.2 | | 118 4.3 6.4 9.5 | | 148 5.2 7.6 10.7 | | 177 6.4 8.2 11.6 | | 207 7.3 8.8 12.5 | | 236 7.6 9.5 13.4 | | 266 8.2 10.1 14.3 | |
| | SHD2  | l/s per side Throw (m) 1 2 3 | 106 71 4.0 2.4 5.5 3.7 7.6 6.4 | | 142 94 5.2 3.0 6.4 4.9 9.1 7.3 | | 177 118 5.8 4.0 7.0 5.8 10.1 8.2 | | 212 142 6.4 4.9 7.6 6.4 11.0 9.1 | | 248 165 6.7 5.5 8.5 7.0 11.9 9.8 | | 283 189 7.3 6.1 9.1 7.3 12.8 10.7 | | 319 212 7.6 6.4 9.5 7.9 13.7 11.3 | |
| | SH3S  | l/s per side Throw (m) 1 2 3 | 71 35 3.4 2.4 5.2 3.7 7.3 5.8 | | 94 47 4.6 3.0 9.1 4.6 8.5 6.7 | | 118 59 5.5 4.0 6.7 5.2 9.5 7.3 | | 142 71 6.1 4.6 7.3 5.8 10.7 8.2 | | 165 83 6.4 4.9 7.9 6.1 11.3 8.8 | | 189 94 7.0 5.5 8.5 6.7 12.2 9.5 | | 212 106 7.3 5.8 9.1 7.0 12.8 10.1 | |
| | SH3L  | l/s per side Throw (m) 1 2 3 | 55 61 3.4 2.4 5.2 3.7 8.2 6.4 | | 74 81 4.6 3.0 6.7 4.9 9.5 7.3 | | 92 101 5.5 4.0 7.3 5.8 10.7 8.2 | | 110 122 6.7 4.9 8.2 6.4 11.6 9.1 | | 129 142 7.3 5.5 8.8 7.0 12.5 9.8 | | 148 162 7.6 6.1 9.5 7.3 13.4 10.7 | | 166 183 8.2 6.4 10.1 7.9 14.3 11.3 | |
| | SH4R  | l/s per side Throw (m) 1 2 3 | 53 35 3.4 2.4 5.2 3.7 7.3 5.8 | | 71 47 4.6 3.0 6.1 4.6 8.5 6.7 | | 89 59 5.5 4.0 6.7 5.2 9.5 7.3 | | 106 71 6.1 4.6 7.3 5.8 10.7 8.2 | | 124 83 6.4 4.9 7.9 6.1 11.3 8.8 | | 142 94 7.0 5.5 8.5 6.7 12.2 9.5 | | 160 106 7.3 5.8 9.1 7.0 12.8 10.1 | |

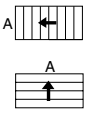
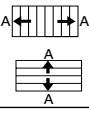
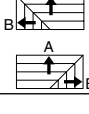
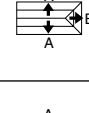
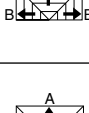
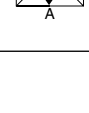
| | | Total l/s NC Side | 212 | | 283 | | 354 | | 425 | | 496 | | 566 | | 637 | |
|-------|--|---------------------------------------|---|---|--|---|---|---|--|---|--|---|---|---|---|--|
| | | | A | B | A | B | A | B | A | B | A | B | A | B | | |
| 300 X | SH1  | l/s per side Throw (m) 1 2 3 | 212 6.4 7.6 11.0 | | 283 7.3 8.8 12.8 | | 354 8.2 10.1 14.3 | | 425 8.8 11.0 15.5 | | 496 9.8 11.9 16.8 | | 566 10.4 12.8 18.0 | | 637 11.0 13.4 19.2 | |
| | SH2  | l/s per side Throw (m) 1 2 3 | 106 3.4 5.2 9.1 | | 142 4.6 7.0 10.4 | | 177 5.8 8.2 11.6 | | 212 7.0 9.1 12.8 | | 248 7.9 9.8 13.7 | | 283 8.5 10.4 14.9 | | 319 9.1 11.0 15.9 | |
| | SHD2  | l/s per side Throw (m) 1 2 3 | 142 71 4.3 2.4 6.1 4.0 8.5 7.0 | | 189 94 5.5 3.4 7.0 5.2 9.8 8.2 | | 236 118 6.4 4.3 7.6 6.4 11.0 9.1 | | 283 142 7.0 5.2 8.5 7.0 12.2 10.1 | | 330 165 7.6 6.1 9.1 7.6 13.1 10.7 | | 378 189 7.9 6.7 9.8 8.2 14.0 11.6 | | 425 212 8.5 7.0 10.4 8.5 14.9 12.2 | |
| | SH3S  | l/s per side Throw (m) 1 2 3 | 89 35 3.7 2.4 5.8 4.0 8.2 6.4 | | 118 47 5.2 3.4 6.7 5.2 9.5 7.3 | | 148 59 6.1 4.3 7.3 5.8 10.7 8.2 | | 177 71 6.7 5.2 8.2 6.4 11.6 8.8 | | 207 83 7.0 5.5 8.8 6.7 12.5 9.8 | | 236 94 7.6 5.8 9.5 7.3 13.4 10.4 | | 266 106 8.2 6.4 10.1 7.6 14.0 11.0 | |
| | SH3L  | l/s per side Throw (m) 1 2 3 | 80 67 3.7 2.4 5.5 4.0 8.8 7.0 | | 106 89 4.9 3.4 7.3 5.2 10.4 8.2 | | 133 110 6.1 4.3 8.2 6.4 11.6 9.1 | | 160 133 7.3 5.2 8.8 7.0 12.8 10.1 | | 186 155 7.9 6.1 9.8 7.6 13.7 10.7 | | 212 177 8.5 6.7 10.4 8.2 14.6 11.6 | | 239 199 8.8 7.0 11.0 8.5 15.5 12.2 | |
| | SH4R  | l/s per side Throw (m) 1 2 3 | 71 35 3.7 2.4 5.8 4.0 8.2 6.4 | | 94 47 5.2 3.4 6.7 5.2 9.5 7.3 | | 118 59 6.1 4.3 7.3 5.8 10.7 8.2 | | 142 71 6.7 5.2 8.2 6.4 11.6 8.8 | | 165 83 7.0 5.5 8.8 6.7 12.5 9.8 | | 189 94 7.6 5.8 9.5 7.3 13.4 10.4 | | 212 106 8.2 6.4 10.1 7.6 14.0 11.0 | |

Performance Data

SH Rectangular Diffusers

| Nominal Size (mm) | Air Pattern (viewed from neck) | Neck Vel. (m/s) | 1.5 | 2.0 | 2.5 | 3.0 | 3.5 | 4.0 | 4.5 |
|-------------------|--------------------------------|-------------------|-----|-----|-----|-----|-----|-----|-----|
| | | Total Press. (Pa) | 11 | 19 | 29 | 42 | 57 | 75 | 94 |



| | | | | | | | | | | | | | | | | |
|---|-----|-------------------|--------------|------|-----------|------|-----------|------|-----------|------|-----------|------|-----------|------|-----------|---|
| 300 X 525 | | Total l/s NC Side | 248 12 | | 330 19 | | 413 25 | | 496 30 | | 578 34 | | 661 37 | | 743 40 | |
| | | | A | B | A | B | A | B | A | B | A | B | A | B | A | B |
| | SH1 | | l/s per side | | 248 | | 330 | | 413 | | 496 | | 578 | | 743 | |
| | | | Throw (m) | | 1 | | 2 | | 3 | | 4 | | 5 | | 6 | |
| | | | 1 | | 6.7 | | 7.9 | | 8.8 | | 9.8 | | 10.4 | | 11.3 | |
| | | | 2 | | 8.2 | | 9.8 | | 10.7 | | 11.9 | | 12.8 | | 13.7 | |
| | | 3 | | 11.9 | | 13.7 | | 15.2 | | 16.8 | | 18.3 | | 19.5 | | |
| SH2 | | l/s per side | | 124 | | 165 | | 207 | | 248 | | 289 | | 330 | | |
| | | Throw (m) | | 1 | | 2 | | 3 | | 4 | | 5 | | 6 | | |
| | | 1 | | 3.7 | | 4.9 | | 6.1 | | 7.3 | | 8.5 | | 9.1 | | |
| | | 2 | | 5.5 | | 7.3 | | 8.8 | | 9.8 | | 10.7 | | 11.3 | | |
| | | 3 | | 9.8 | | 11.3 | | 12.5 | | 13.7 | | 14.9 | | 16.2 | | |
| SHD2 | | l/s per side | | 177 | | 236 | | 295 | | 354 | | 413 | | 472 | | |
| | | Throw (m) | | 1 | | 2 | | 3 | | 4 | | 5 | | 6 | | |
| | | 1 | | 4.6 | | 6.1 | | 6.7 | | 7.6 | | 8.2 | | 8.5 | | |
| | | 2 | | 6.4 | | 7.6 | | 8.5 | | 9.1 | | 10.1 | | 10.7 | | |
| | | 3 | | 9.1 | | 10.7 | | 11.9 | | 13.1 | | 14.0 | | 15.2 | | |
| SH3S | | l/s per side | | 106 | | 142 | | 177 | | 212 | | 248 | | 283 | | |
| | | Throw (m) | | 1 | | 2 | | 3 | | 4 | | 5 | | 6 | | |
| | | 1 | | 4.0 | | 5.5 | | 6.4 | | 7.0 | | 7.6 | | 8.2 | | |
| | | 2 | | 6.1 | | 7.0 | | 7.9 | | 8.8 | | 9.5 | | 10.1 | | |
| | | 3 | | 8.8 | | 10.1 | | 11.3 | | 12.5 | | 13.4 | | 14.3 | | |
| SH3L | | l/s per side | | 109 | | 144 | | 181 | | 217 | | 253 | | 289 | | |
| | | Throw (m) | | 1 | | 2 | | 3 | | 4 | | 5 | | 6 | | |
| | | 1 | | 4.0 | | 5.2 | | 6.7 | | 7.9 | | 8.5 | | 9.1 | | |
| | | 2 | | 6.1 | | 7.9 | | 8.8 | | 9.8 | | 10.4 | | 11.3 | | |
| | | 3 | | 9.8 | | 11.3 | | 12.5 | | 13.7 | | 14.9 | | 15.9 | | |
| SH4R | | l/s per side | | 88 | | 118 | | 147 | | 177 | | 206 | | 236 | | |
| | | Throw (m) | | 1 | | 2 | | 3 | | 4 | | 5 | | 6 | | |
| | | 1 | | 4.0 | | 5.5 | | 6.4 | | 7.0 | | 7.6 | | 8.2 | | |
| | | 2 | | 6.1 | | 7.0 | | 7.9 | | 8.8 | | 9.5 | | 10.1 | | |
| | | 3 | | 8.8 | | 10.1 | | 11.3 | | 12.5 | | 13.4 | | 14.3 | | |

| | | | | | | | | | | | | | | | | |
|---|-----|-------------------|--------------|------|-----------|------|-----------|------|-----------|------|-----------|------|-----------|------|-----------|---|
| 300 X 600 | | Total l/s NC Side | 283 12 | | 378 20 | | 472 25 | | 566 30 | | 661 34 | | 755 38 | | 850 41 | |
| | | | A | B | A | B | A | B | A | B | A | B | A | B | A | B |
| | SH1 | | l/s per side | | 283 | | 378 | | 472 | | 566 | | 661 | | 755 | |
| | | | Throw (m) | | 1 | | 2 | | 3 | | 4 | | 5 | | 6 | |
| | | | 1 | | 7.3 | | 8.5 | | 9.5 | | 10.4 | | 11.3 | | 11.9 | |
| | | | 2 | | 8.8 | | 10.4 | | 11.6 | | 12.8 | | 13.7 | | 14.6 | |
| | | 3 | | 12.8 | | 14.6 | | 16.5 | | 18.0 | | 19.5 | | 20.7 | | |
| SH2 | | l/s per side | | 142 | | 189 | | 236 | | 283 | | 330 | | 378 | | |
| | | Throw (m) | | 1 | | 2 | | 3 | | 4 | | 5 | | 6 | | |
| | | 1 | | 4.0 | | 5.2 | | 6.7 | | 7.9 | | 9.1 | | 9.8 | | |
| | | 2 | | 5.8 | | 7.9 | | 9.5 | | 10.4 | | 11.3 | | 12.2 | | |
| | | 3 | | 10.4 | | 12.2 | | 13.4 | | 14.9 | | 16.2 | | 17.1 | | |
| SHD2 | | l/s per side | | 212 | | 283 | | 354 | | 425 | | 496 | | 566 | | |
| | | Throw (m) | | 1 | | 2 | | 3 | | 4 | | 5 | | 6 | | |
| | | 1 | | 4.9 | | 6.4 | | 7.3 | | 7.9 | | 8.5 | | 9.1 | | |
| | | 2 | | 7.0 | | 9.1 | | 9.1 | | 9.8 | | 10.7 | | 11.3 | | |
| | | 3 | | 9.8 | | 11.3 | | 12.8 | | 14.0 | | 15.2 | | 16.2 | | |
| SH3S | | l/s per side | | 124 | | 165 | | 207 | | 248 | | 289 | | 330 | | |
| | | Throw (m) | | 1 | | 2 | | 3 | | 4 | | 5 | | 6 | | |
| | | 1 | | 4.3 | | 5.8 | | 7.0 | | 7.6 | | 8.2 | | 8.8 | | |
| | | 2 | | 6.7 | | 7.6 | | 8.5 | | 9.5 | | 10.1 | | 11.0 | | |
| | | 3 | | 9.5 | | 11.0 | | 12.2 | | 13.4 | | 14.3 | | 15.5 | | |
| SH3L | | l/s per side | | 142 | | 189 | | 236 | | 283 | | 330 | | 378 | | |
| | | Throw (m) | | 1 | | 2 | | 3 | | 4 | | 5 | | 6 | | |
| | | 1 | | 5.8 | | 7.3 | | 8.2 | | 9.1 | | 9.8 | | 10.7 | | |
| | | 2 | | 7.9 | | 9.1 | | 10.1 | | 11.3 | | 12.2 | | 13.1 | | |
| | | 3 | | 11.3 | | 13.1 | | 14.6 | | 15.9 | | 17.1 | | 18.3 | | |
| SH4R | | l/s per side | | 106 | | 142 | | 177 | | 212 | | 248 | | 283 | | |
| | | Throw (m) | | 1 | | 2 | | 3 | | 4 | | 5 | | 6 | | |
| | | 1 | | 4.3 | | 5.8 | | 7.0 | | 7.6 | | 8.2 | | 8.8 | | |
| | | 2 | | 6.7 | | 7.6 | | 8.5 | | 9.5 | | 10.1 | | 11.0 | | |
| | | 3 | | 9.5 | | 11.0 | | 12.2 | | 13.4 | | 14.3 | | 15.5 | | |

Performance Data

SH Rectangular Diffusers

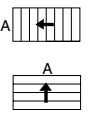
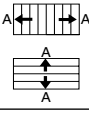
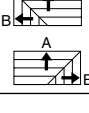
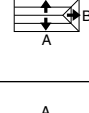
| Nominal Size (mm) | Air Pattern (viewed from neck) | Neck Vel. (m/s) | 1.5 | 2.0 | 2.5 | 3.0 | 3.5 | 4.0 | 4.5 |
|-------------------|--------------------------------|-------------------|-----|-----|-----|-----|-----|-----|-----|
| | | Total Press. (Pa) | 11 | 19 | 29 | 42 | 57 | 75 | 94 |

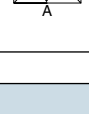
| | | Total l/s NC Side | 354 13 | | 472 20 | | 590 26 | | 708 31 | | 826 35 | | 944 38 | | 1 062 41 | |
|--|---|---|------------|------------|------------|------------|-------------|-------------|-------------|-------------|-------------|-------------|-------------|-------------|---------------|---|
| | | | A | B | A | B | A | B | A | B | A | B | A | B | A | B |
| 300 X 750 | SH1  | l/s per side Throw (m) | 354 8.2 | | 472 9.5 | | 590 10.7 | | 708 11.6 | | 826 12.5 | | 944 13.4 | | 1 062 14.3 | |
| | | 2 | 10.1 | | 11.6 | | 12.8 | | 14.3 | | 15.2 | | 16.5 | | 17.4 | |
| | | 3 | 14.3 | | 16.5 | | 18.3 | | 20.1 | | 21.6 | | 23.2 | | 24.7 | |
| | SH2  | l/s per side Throw (m) | 177 4.3 | | 236 5.8 | | 295 7.3 | | 354 8.8 | | 413 10.4 | | 472 11.0 | | 531 11.6 | |
| | | 2 | 6.7 | | 8.8 | | 10.7 | | 11.6 | | 12.5 | | 13.4 | | 14.3 | |
| | | 3 | 11.6 | | 13.4 | | 15.2 | | 15.9 | | 18.0 | | 19.2 | | 20.4 | |
| SHD2  | l/s per side Throw (m) | 283 5.5 | 71 3.4 | 378 7.3 | 94 4.6 | 472 8.2 | 118 5.8 | 566 9.1 | 142 6.7 | 661 9.8 | 165 7.9 | 755 10.4 | 189 8.5 | 850 11.0 | 212 9.1 | |
| | 2 | 7.6 | 5.2 | 9.1 | 6.7 | 10.1 | 8.2 | 11.0 | 9.1 | 11.9 | 9.8 | 12.8 | 10.7 | 13.7 | 11.3 | |
| | 3 | 11.0 | 9.1 | 12.8 | 10.7 | 14.3 | 11.9 | 15.5 | 12.8 | 17.1 | 14.0 | 18.3 | 14.9 | 19.2 | 15.9 | |
| SH3S  | l/s per side Throw (m) | 160 4.9 | 35 3.4 | 212 6.7 | 47 4.6 | 266 7.9 | 59 5.5 | 319 8.5 | 71 6.7 | 372 9.1 | 83 7.0 | 425 10.1 | 94 7.6 | 478 10.7 | 106 8.2 | |
| | 2 | 7.3 | 4.9 | 8.5 | 6.7 | 9.5 | 7.3 | 10.7 | 8.2 | 11.3 | 8.8 | 12.2 | 9.5 | 12.8 | 10.1 | |
| | 3 | 10.7 | 8.2 | 12.2 | 9.5 | 13.7 | 10.7 | 14.9 | 11.6 | 16.2 | 12.5 | 17.4 | 13.4 | 18.3 | 14.3 | |
| SH3L  | l/s per side Throw (m) | 212 7.3 | 71 3.4 | 283 8.5 | 94 4.6 | 354 9.5 | 118 5.8 | 425 10.4 | 142 6.7 | 496 11.3 | 165 7.9 | 566 11.9 | 189 8.5 | 637 12.8 | 212 9.1 | |
| | 2 | 8.8 | 5.2 | 10.4 | 6.7 | 11.6 | 8.2 | 12.8 | 9.1 | 13.7 | 9.8 | 14.6 | 10.7 | 15.5 | 11.3 | |
| | 3 | 12.8 | 9.1 | 14.6 | 10.7 | 16.5 | 11.9 | 18.0 | 12.8 | 19.5 | 14.0 | 20.7 | 14.9 | 22.0 | 15.9 | |
| SH4R  | l/s per side Throw (m) | 142 4.9 | 35 3.4 | 189 6.7 | 47 4.6 | 236 7.9 | 59 5.5 | 283 8.5 | 71 6.7 | 330 9.1 | 83 7.0 | 378 10.1 | 94 7.6 | 425 10.7 | 106 8.2 | |
| | 2 | 7.3 | 4.9 | 8.5 | 6.7 | 9.5 | 7.3 | 10.7 | 8.2 | 11.3 | 8.8 | 12.2 | 9.5 | 12.8 | 10.1 | |
| | 3 | 10.7 | 8.2 | 12.2 | 9.5 | 13.7 | 10.7 | 14.9 | 11.6 | 16.2 | 12.5 | 17.4 | 13.4 | 18.3 | 14.3 | |

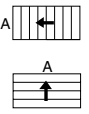
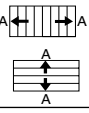
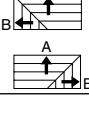
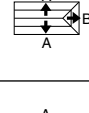
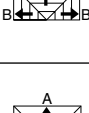
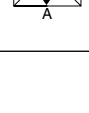

| | | Total l/s NC Side | 425 13 | | 566 21 | | 708 27 | | 850 31 | | 991 36 | | 1 133 39 | | 1 274 42 | |
|--|---|---|------------|------------|-------------|-------------|-------------|-------------|-------------|-------------|-------------|-------------|---------------|---------------|---------------|---|
| | | | A | B | A | B | A | B | A | B | A | B | A | B | A | B |
| 300 X 900 | SH1  | l/s per side Throw (m) | 425 8.8 | | 566 10.4 | | 708 11.6 | | 850 12.8 | | 991 13.7 | | 1 133 14.6 | | 1 274 15.5 | |
| | | 2 | 11.0 | | 12.8 | | 14.3 | | 15.5 | | 16.8 | | 18.0 | | 19.2 | |
| | | 3 | 15.5 | | 18.0 | | 20.1 | | 22.0 | | 23.8 | | 25.6 | | 27.1 | |
| | SH2  | l/s per side Throw (m) | 212 4.9 | | 283 6.4 | | 354 8.2 | | 425 9.8 | | 496 11.3 | | 566 12.2 | | 637 12.8 | |
| | | 2 | 7.3 | | 9.8 | | 11.6 | | 12.8 | | 13.7 | | 14.9 | | 15.9 | |
| | | 3 | 12.8 | | 14.9 | | 16.5 | | 18.3 | | 19.5 | | 21.0 | | 22.3 | |
| SHD2  | l/s per side Throw (m) | 354 6.1 | 71 3.7 | 472 7.9 | 94 4.9 | 590 9.1 | 118 6.1 | 708 9.8 | 142 7.6 | 826 10.7 | 165 8.8 | 944 11.3 | 189 9.5 | 1 062 12.2 | 212 10.1 | |
| | 2 | 8.5 | 5.5 | 9.8 | 7.6 | 11.0 | 9.1 | 12.2 | 10.1 | 13.1 | 10.7 | 14.0 | 11.6 | 14.9 | 12.2 | |
| | 3 | 12.2 | 10.1 | 14.0 | 11.6 | 15.5 | 12.8 | 17.1 | 14.0 | 18.6 | 15.2 | 19.8 | 16.5 | 21.0 | 17.4 | |
| SH3S  | l/s per side Throw (m) | 194 5.5 | 35 3.7 | 260 7.3 | 47 4.9 | 324 8.5 | 59 6.1 | 389 9.5 | 71 7.3 | 454 10.1 | 83 7.9 | 519 11.0 | 94 8.5 | 584 11.6 | 106 8.8 | |
| | 2 | 8.2 | 5.5 | 9.5 | 7.3 | 10.7 | 8.2 | 11.6 | 8.8 | 12.5 | 9.8 | 13.4 | 10.4 | 14.0 | 11.0 | |
| | 3 | 11.6 | 8.8 | 13.4 | 10.4 | 14.9 | 11.6 | 16.5 | 12.8 | 17.7 | 13.7 | 18.9 | 14.6 | 20.1 | 15.5 | |
| SH3L  | l/s per side Throw (m) | 283 7.9 | 71 3.7 | 378 9.1 | 94 4.9 | 472 10.4 | 118 6.1 | 566 11.3 | 142 7.6 | 661 12.2 | 165 8.8 | 755 13.1 | 189 9.5 | 850 14.0 | 212 10.1 | |
| | 2 | 9.8 | 5.5 | 11.3 | 7.6 | 12.8 | 9.1 | 14.0 | 10.1 | 14.9 | 10.7 | 16.2 | 11.6 | 17.1 | 12.2 | |
| | 3 | 14.0 | 10.1 | 16.2 | 11.6 | 18.0 | 12.8 | 19.8 | 14.0 | 21.3 | 15.2 | 22.9 | 16.5 | 24.1 | 17.4 | |
| SH4R  | l/s per side Throw (m) | 177 5.5 | 35 3.7 | 236 7.3 | 47 4.9 | 295 8.5 | 59 6.1 | 354 9.5 | 70 7.3 | 413 10.1 | 82 7.9 | 472 11.0 | 94 8.5 | 531 11.6 | 106 8.8 | |
| | 2 | 8.2 | 5.5 | 9.5 | 7.3 | 10.7 | 8.2 | 11.6 | 8.8 | 12.5 | 9.8 | 13.4 | 10.4 | 14.0 | 11.0 | |
| | 3 | 11.6 | 8.8 | 13.4 | 10.4 | 14.9 | 11.6 | 16.5 | 12.8 | 17.7 | 13.7 | 18.9 | 14.6 | 20.1 | 15.5 | |

Performance Data

SH Rectangular Diffusers

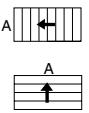
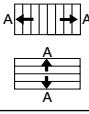
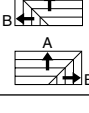
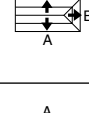
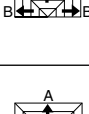
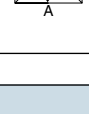
| Nominal Size (mm) | Air Pattern (viewed from neck) | Neck Vel. (m/s) | 1.5 | 2.0 | 2.5 | 3.0 | 3.5 | 4.0 | 4.5 |
|-------------------|--------------------------------|-------------------|-----|-----|-----|-----|-----|-----|-----|
| | | Total Press. (Pa) | 11 | 19 | 29 | 42 | 57 | 75 | 94 |

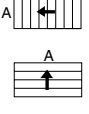
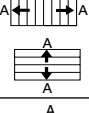
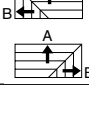
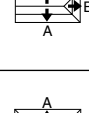
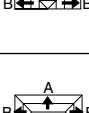
| Nominal Size (mm) | Air Pattern (viewed from neck) | Total l/s NC Side | 266 | | 354 | | 443 | | 531 | | 620 | | 708 | | 797 | |
|--|---|---------------------------------------|------|------|------|------|------|------|------|------|------|------|------|------|------|---|
| | | | 12 | | 19 | | 25 | | 30 | | 34 | | 37 | | 41 | |
| | | | A | B | A | B | A | B | A | B | A | B | A | B | A | B |
| 375 X 450 | SH1  | l/s per side Throw (m) 1 2 3 | 266 | | 354 | | 443 | | 531 | | 620 | | 708 | | 797 | |
| | 7.0 | | | 8.2 | | 9.1 | | 10.1 | | 10.7 | | 11.6 | | 12.2 | | |
| | 8.5 | | | 10.1 | | 11.3 | | 12.2 | | 13.4 | | 14.3 | | 14.9 | | |
| | | | 12.2 | | 14.3 | | 15.9 | | 17.4 | | 18.9 | | 20.1 | | 21.3 | |
| | SH2  | l/s per side Throw (m) 1 2 3 | 133 | | 177 | | 221 | | 266 | | 310 | | 354 | | 398 | |
| | 3.7 | | | 5.2 | | 6.4 | | 7.6 | | 8.8 | | 9.5 | | 10.1 | | |
| 5.8 | | | 7.6 | | 9.1 | | 10.1 | | 11.0 | | 11.6 | | 12.5 | | | |
| | | 10.1 | | 11.6 | | 13.1 | | 14.3 | | 15.5 | | 16.5 | | 17.7 | | |
| SHD2  | l/s per side Throw (m) 1 2 3 | 155 | 110 | 206 | 148 | 258 | 185 | 310 | 221 | 362 | 258 | 413 | 295 | 464 | 332 | |
| 4.9 | | 2.7 | 6.4 | 4.0 | 7.0 | 4.9 | 7.6 | 5.8 | 8.5 | 7.0 | 9.1 | 7.3 | 9.5 | 7.9 | | |
| 6.7 | | 4.3 | 7.6 | 5.8 | 8.8 | 7.0 | 9.5 | 7.9 | 10.4 | 8.5 | 11.0 | 9.1 | 11.6 | 9.8 | | |
| | | 9.5 | 7.9 | 11.0 | 9.1 | 12.5 | 10.1 | 13.7 | 11.3 | 14.6 | 12.2 | 15.5 | 12.8 | 16.8 | 13.7 | |
| SH3S  | l/s per side Throw (m) 1 2 3 | 105 | 55 | 140 | 74 | 175 | 92 | 210 | 110 | 245 | 129 | 280 | 147 | 315 | 166 | |
| 4.3 | | 2.7 | 5.8 | 4.0 | 6.7 | 4.9 | 7.3 | 5.8 | 7.9 | 6.1 | 8.5 | 6.7 | 9.1 | 7.0 | | |
| 6.4 | | 4.3 | 7.3 | 5.8 | 8.2 | 6.4 | 9.1 | 7.0 | 9.8 | 7.6 | 10.7 | 8.2 | 11.3 | 8.5 | | |
| | | 9.1 | 7.0 | 10.7 | 8.2 | 11.9 | 9.1 | 12.8 | 10.1 | 14.0 | 10.7 | 14.9 | 11.6 | 15.9 | 12.2 | |
| SH3L  | l/s per side Throw (m) 1 2 3 | 80 | 93 | 106 | 124 | 133 | 155 | 160 | 186 | 186 | 217 | 212 | 248 | 239 | 279 | |
| 4.0 | | 2.7 | 5.5 | 4.0 | 7.0 | 4.9 | 8.2 | 5.8 | 8.8 | 7.0 | 9.5 | 7.3 | 10.1 | 7.9 | | |
| 6.1 | | 4.3 | 8.2 | 5.8 | 9.1 | 7.0 | 10.1 | 7.9 | 11.0 | 8.5 | 11.6 | 9.1 | 12.2 | 9.8 | | |
| | | 10.1 | 7.9 | 11.6 | 9.1 | 13.1 | 10.1 | 14.3 | 11.3 | 15.2 | 12.2 | 16.5 | 12.8 | 17.4 | 13.7 | |
| SH4R  | l/s per side Throw (m) 1 2 3 | 77 | 55 | 103 | 74 | 129 | 92 | 155 | 110 | 181 | 129 | 207 | 147 | 232 | 166 | |
| 4.3 | | 2.7 | 5.8 | 4.0 | 6.7 | 4.9 | 7.3 | 5.8 | 7.9 | 6.1 | 8.5 | 6.7 | 9.1 | 7.0 | | |
| 6.4 | | 4.3 | 7.3 | 5.8 | 8.2 | 6.4 | 9.1 | 7.0 | 9.8 | 7.6 | 10.7 | 8.2 | 11.3 | 8.5 | | |
| | | 9.1 | 7.0 | 10.7 | 8.2 | 11.9 | 9.1 | 12.8 | 10.1 | 14.0 | 10.7 | 14.9 | 11.6 | 15.9 | 12.2 | |



| Nominal Size (mm) | Air Pattern (viewed from neck) | Total l/s NC Side | 310 | | 413 | | 516 | | 620 | | 723 | | 826 | | 929 | |
|--|---|---------------------------------------|------|------|------|------|------|------|------|------|------|------|------|------|------|---|
| | | | 12 | | 20 | | 26 | | 30 | | 34 | | 38 | | 41 | |
| | | | A | B | A | B | A | B | A | B | A | B | A | B | A | B |
| 375 X 525 | SH1  | l/s per side Throw (m) 1 2 3 | 310 | | 413 | | 516 | | 620 | | 723 | | 826 | | 929 | |
| | 7.6 | | | 8.8 | | 9.8 | | 10.7 | | 11.6 | | 12.5 | | 13.4 | | |
| | 9.5 | | | 10.7 | | 12.2 | | 13.4 | | 14.3 | | 15.2 | | 16.2 | | |
| | | | 13.4 | | 15.2 | | 17.1 | | 18.9 | | 20.4 | | 21.6 | | 23.2 | |
| | SH2  | l/s per side Throw (m) 1 2 3 | 155 | | 207 | | 258 | | 310 | | 362 | | 413 | | 464 | |
| | 4.0 | | | 5.5 | | 7.0 | | 8.2 | | 9.8 | | 10.4 | | 11.0 | | |
| 6.1 | | | 8.2 | | 10.1 | | 11.0 | | 11.9 | | 12.5 | | 13.4 | | | |
| | | 11.0 | | 12.5 | | 14.0 | | 15.5 | | 16.8 | | 18.0 | | 18.9 | | |
| SHD2  | l/s per side Throw (m) 1 2 3 | 199 | 110 | 266 | 147 | 332 | 185 | 398 | 221 | 464 | 258 | 531 | 295 | 598 | 332 | |
| 5.2 | | 3.0 | 6.7 | 4.3 | 7.6 | 5.2 | 8.5 | 6.4 | 9.1 | 7.6 | 9.8 | 7.9 | 10.4 | 8.5 | | |
| 7.3 | | 4.9 | 8.5 | 6.4 | 9.5 | 7.6 | 10.4 | 8.5 | 11.3 | 9.1 | 11.9 | 9.8 | 12.8 | 10.4 | | |
| | | 10.4 | 8.5 | 11.9 | 9.8 | 13.4 | 11.0 | 14.6 | 12.2 | 15.9 | 13.1 | 17.1 | 14.0 | 18.0 | 14.9 | |
| SH3S  | l/s per side Throw (m) 1 2 3 | 127 | 55 | 169 | 74 | 212 | 92 | 254 | 110 | 297 | 129 | 339 | 148 | 382 | 166 | |
| 4.6 | | 3.0 | 6.1 | 4.3 | 7.3 | 5.2 | 7.9 | 6.1 | 8.5 | 6.7 | 9.1 | 7.0 | 9.8 | 7.6 | | |
| 7.0 | | 4.6 | 7.9 | 6.1 | 8.8 | 7.0 | 9.8 | 7.6 | 10.7 | 8.2 | 11.3 | 8.8 | 12.2 | 9.5 | | |
| | | 9.8 | 7.6 | 11.3 | 8.8 | 12.8 | 9.8 | 14.0 | 10.7 | 15.2 | 11.6 | 16.2 | 12.5 | 17.1 | 13.1 | |
| SH3L  | l/s per side Throw (m) 1 2 3 | 109 | 101 | 144 | 134 | 181 | 168 | 217 | 202 | 253 | 235 | 289 | 269 | 325 | 302 | |
| 4.3 | | 3.0 | 5.8 | 4.3 | 7.3 | 5.2 | 8.8 | 6.4 | 9.5 | 7.6 | 10.1 | 7.9 | 11.0 | 8.5 | | |
| 6.7 | | 4.9 | 8.8 | 6.4 | 9.8 | 7.6 | 11.0 | 8.5 | 11.6 | 9.1 | 12.5 | 9.8 | 13.4 | 10.4 | | |
| | | 11.0 | 8.5 | 12.5 | 9.8 | 14.0 | 11.0 | 15.2 | 12.2 | 16.8 | 13.1 | 17.7 | 14.0 | 18.9 | 14.9 | |
| SH4R  | l/s per side Throw (m) 1 2 3 | 100 | 55 | 133 | 74 | 166 | 92 | 199 | 110 | 232 | 129 | 265 | 148 | 299 | 166 | |
| 4.6 | | 3.0 | 6.1 | 4.3 | 7.3 | 5.2 | 7.9 | 6.1 | 8.5 | 6.7 | 9.1 | 7.0 | 9.8 | 7.6 | | |
| 7.0 | | 4.6 | 7.9 | 6.1 | 8.8 | 7.0 | 9.8 | 7.6 | 10.7 | 8.2 | 11.3 | 8.8 | 12.2 | 9.5 | | |
| | | 9.8 | 7.6 | 11.3 | 8.8 | 12.8 | 9.8 | 14.0 | 10.7 | 15.2 | 11.6 | 16.2 | 12.5 | 17.1 | 13.1 | |

Performance Data

SH Rectangular Diffusers

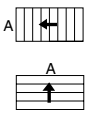
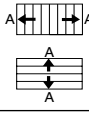
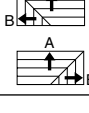
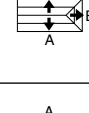
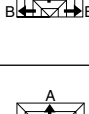
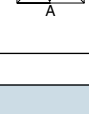
| Nominal Size (mm) | Air Pattern (viewed from neck) | Neck Vel. (m/s) | 1.5 | 2.0 | 2.5 | 3.0 | 3.5 | 4.0 | 4.5 |
|-------------------|--------------------------------|-------------------|-----|-----|-----|-----|-----|-----|-----|
| | | Total Press. (Pa) | 11 | 19 | 29 | 42 | 57 | 75 | 94 |

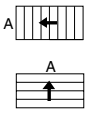
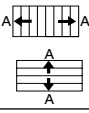
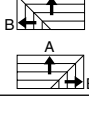
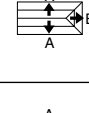
| Nominal Size (mm) | Air Pattern (viewed from neck) | Total l/s NC Side | 354 | | 472 | | 590 | | 708 | | 826 | | 944 | | 1 062 | |
|-------------------|--|---------------------------------------|----------------------------|--------------------------|----------------------------|---------------------------|-----------------------------|---------------------------|-----------------------------|---------------------------|-----------------------------|---------------------------|-----------------------------|----------------------------|-------------------------------|----------------------------|
| | | | 13 | | 20 | | 26 | | 31 | | 35 | | 38 | | 41 | |
| | | | A | B | A | B | A | B | A | B | A | B | A | B | A | B |
| 375 X 600 | SH1  | I/s per side Throw (m) 1 2 3 | 354 8.2 10.1 14.3 | | 472 9.5 11.6 16.5 | | 590 10.7 12.8 18.3 | | 708 11.6 14.3 20.1 | | 826 12.5 15.2 21.6 | | 944 13.4 16.5 23.2 | | 1 062 14.3 17.4 24.7 | |
| | SH2  | I/s per side Throw (m) 1 2 3 | 177 4.3 6.7 11.6 | | 236 5.8 8.8 13.4 | | 295 7.3 10.7 15.2 | | 354 8.8 11.6 15.9 | | 413 10.4 12.5 18.0 | | 472 11.0 13.4 19.2 | | 531 11.6 14.3 20.4 | |
| | SHD2  | I/s per side Throw (m) 1 2 3 | 244 5.5 7.6 11.0 | 110 3.4 5.2 9.1 | 325 7.3 9.1 12.8 | 148 4.6 6.7 10.7 | 405 8.2 10.1 14.3 | 185 5.8 8.2 11.9 | 487 9.1 11.0 15.5 | 221 6.7 9.1 12.8 | 568 9.8 11.9 17.1 | 258 7.9 9.8 14.3 | 649 10.4 12.8 18.3 | 295 8.5 10.7 14.9 | 730 11.0 13.7 19.2 | 332 9.1 11.3 15.9 |
| | SH3S  | I/s per side Throw (m) 1 2 3 | 149 4.9 7.3 10.7 | 55 3.4 4.9 8.2 | 199 6.7 8.5 12.2 | 74 4.6 6.7 9.5 | 249 7.9 9.5 13.7 | 92 5.5 7.3 10.7 | 299 8.5 10.7 14.9 | 110 6.7 8.2 11.6 | 348 9.1 11.3 16.2 | 129 7.0 8.8 12.5 | 398 10.1 12.2 17.4 | 148 7.6 9.5 13.4 | 448 10.7 12.8 18.3 | 166 8.2 10.1 14.3 |
| | SH3L  | I/s per side Throw (m) 1 2 3 | 142 4.9 7.3 11.6 | 106 3.4 5.2 9.1 | 189 6.4 9.5 13.4 | 142 4.6 6.7 10.7 | 236 7.9 10.7 14.9 | 177 5.8 8.2 11.9 | 283 9.5 11.6 16.5 | 212 6.7 9.1 12.8 | 330 10.1 12.5 17.7 | 248 7.9 9.8 14.0 | 378 11.0 13.4 18.9 | 283 8.5 10.7 14.9 | 425 11.6 14.3 20.1 | 319 9.1 11.3 15.9 |
| | SH4R  | I/s per side Throw (m) 1 2 3 | 122 4.9 7.3 10.7 | 55 3.4 4.9 8.2 | 162 6.7 8.5 12.2 | 74 4.6 6.7 9.5 | 203 7.9 9.5 13.7 | 92 5.5 7.3 10.7 | 244 8.5 10.7 14.9 | 110 6.7 8.2 11.6 | 284 9.1 11.3 16.2 | 129 7.0 8.8 12.5 | 325 10.1 12.2 17.4 | 148 7.6 9.5 13.4 | 365 10.7 12.8 18.3 | 166 8.2 10.1 14.3 |

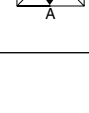
| Nominal Size (mm) | Air Pattern (viewed from neck) | Total l/s NC Side | 443 | | 590 | | 738 | | 885 | | 1 033 | | 1 180 | | 1 328 | |
|-------------------|--|---------------------------------------|----------------------------|---------------------------|-----------------------------|---------------------------|-----------------------------|---------------------------|-----------------------------|----------------------------|-------------------------------|----------------------------|-------------------------------|----------------------------|-------------------------------|-----------------------------|
| | | | 13 | | 21 | | 27 | | 32 | | 36 | | 39 | | 42 | |
| | | | A | B | A | B | A | B | A | B | A | B | A | B | A | B |
| 375 X 750 | SH1  | I/s per side Throw (m) 1 2 3 | 443 9.1 11.3 15.9 | | 590 10.7 12.8 18.3 | | 738 11.9 14.6 20.4 | | 885 12.8 15.9 22.6 | | 1 033 14.0 17.1 24.4 | | 1 180 14.9 18.3 25.9 | | 1 328 15.9 19.5 27.7 | |
| | SH2  | I/s per side Throw (m) 1 2 3 | 221 4.9 7.3 13.1 | | 295 6.7 10.1 15.2 | | 369 8.2 11.9 17.1 | | 443 10.1 13.1 18.6 | | 516 11.6 14.0 20.1 | | 590 12.2 15.2 21.3 | | 664 13.1 16.2 22.9 | |
| | SHD2  | I/s per side Throw (m) 1 2 3 | 332 6.4 8.8 12.5 | 110 3.7 5.8 10.1 | 443 8.2 10.1 14.3 | 148 5.2 7.6 11.9 | 553 9.1 11.3 16.2 | 185 6.4 9.1 13.1 | 664 10.1 12.5 17.7 | 221 7.6 10.1 14.3 | 775 11.0 13.4 18.9 | 258 8.8 11.0 15.5 | 885 11.6 14.3 20.4 | 295 9.5 11.9 16.8 | 995 12.5 15.2 21.6 | 332 10.1 12.5 17.7 |
| | SH3S  | I/s per side Throw (m) 1 2 3 | 194 5.5 8.2 11.9 | 55 3.7 5.5 9.1 | 258 7.3 9.5 13.7 | 74 4.9 7.3 10.7 | 323 8.8 10.7 15.2 | 92 6.4 8.2 11.9 | 387 9.5 11.9 16.8 | 110 7.3 9.1 12.8 | 452 10.4 12.8 18.0 | 129 7.9 9.8 14.0 | 516 11.0 13.7 19.2 | 148 8.5 10.7 14.9 | 581 11.9 14.3 20.4 | 166 9.1 11.3 15.9 |
| | SH3L  | I/s per side Throw (m) 1 2 3 | 221 7.3 9.8 14.0 | 110 3.7 5.8 10.1 | 295 9.5 11.6 16.2 | 148 5.2 7.6 11.9 | 369 10.4 12.8 18.3 | 185 6.4 9.1 13.1 | 443 11.6 14.0 19.8 | 221 7.6 10.1 14.3 | 516 12.5 15.2 21.6 | 258 8.8 11.0 15.5 | 590 13.1 16.2 23.2 | 295 9.5 11.9 16.8 | 664 14.0 17.4 24.4 | 332 10.1 12.5 17.7 |
| | SH4R  | I/s per side Throw (m) 1 2 3 | 166 5.5 8.2 11.9 | 55 3.7 5.5 9.1 | 221 7.3 9.5 13.7 | 74 4.9 7.3 10.7 | 277 8.8 10.7 15.2 | 92 6.4 8.2 11.9 | 332 9.5 11.9 16.8 | 110 7.3 9.1 12.8 | 387 10.4 12.8 18.0 | 129 7.9 9.8 14.0 | 443 11.0 13.7 19.2 | 148 8.5 10.7 14.9 | 498 11.9 14.3 20.4 | 166 9.1 11.3 15.9 |

Performance Data

SH Rectangular Diffusers

| Nominal Size (mm) | Air Pattern (viewed from neck) | Neck Vel. (m/s) Total Press. (Pa) | 1.5 | 2.0 | 2.5 | 3.0 | 3.5 | 4.0 | 4.5 |
|-------------------|--------------------------------|--------------------------------------|-----|-----|-----|-----|-----|-----|-----|
| | | | 11 | 19 | 29 | 42 | 57 | 75 | 94 |

| | | Total l/s NC Side | 531 14 | | 708 22 | | 885 27 | | 1 062 32 | | 1 239 36 | | 1 416 40 | | 1 593 43 | |
|-------------------------|------|---------------------------------------|-----------------------------|---------------------------|-----------------------------|---------------------------|-----------------------------|----------------------------|-------------------------------|----------------------------|-------------------------------|----------------------------|-------------------------------|-----------------------------|-------------------------------|-----------------------------|
| | | | A | B | A | B | A | B | A | B | A | B | A | B | A | B |
| 375 X 900 | SH1 | l/s per side Throw (m) 1 2 3 | 531 10.1 12.2 17.4 | | 708 11.6 14.3 20.1 | | 885 12.8 15.9 22.6 | | 1 062 14.3 17.4 24.7 | | 1 239 15.2 18.9 26.8 | | 1 416 16.5 20.1 28.7 | | 1 593 15.9 19.5 27.7 | |
| | SH2 | l/s per side Throw (m) 1 2 3 | 266 5.5 8.2 14.3 | | 354 7.3 11.0 16.5 | | 443 9.1 13.1 18.6 | | 531 11.0 14.3 20.4 | | 620 12.5 15.5 22.0 | | 708 13.4 16.5 23.5 | | 797 14.3 17.7 25.0 | |
| | SHD2 | l/s per side Throw (m) 1 2 3 | 421 7.0 9.5 13.7 | 110 4.3 6.4 11.3 | 561 9.1 11.0 15.5 | 147 5.5 8.5 12.8 | 700 10.1 12.5 17.7 | 185 7.0 10.1 14.3 | 841 11.0 13.7 19.2 | 221 8.5 11.3 15.9 | 981 11.9 14.6 20.7 | 258 9.8 12.2 17.1 | 1 121 12.8 15.5 22.3 | 295 10.7 12.8 18.3 | 1 261 13.7 16.8 23.5 | 332 13.7 16.8 23.5 |
| | SH3S | l/s per side Throw (m) 1 2 3 | 238 6.1 9.1 12.8 | 55 4.0 6.1 12.8 | 317 8.2 10.7 14.9 | 74 5.5 8.2 11.6 | 396 9.5 11.9 16.8 | 92 7.0 9.1 12.8 | 476 10.7 12.8 18.3 | 110 8.2 10.1 14.3 | 555 11.3 14.0 19.8 | 129 8.8 10.7 15.2 | 634 12.2 14.9 21.3 | 148 9.5 11.6 16.5 | 714 12.8 15.9 22.6 | 166 10.1 12.2 17.4 |
| | SH3L | l/s per side Throw (m) 1 2 3 | 310 8.8 11.0 15.5 | 110 4.3 6.4 11.3 | 413 10.4 12.8 18.0 | 147 5.5 8.5 12.8 | 516 11.6 14.0 20.1 | 185 7.0 10.1 14.3 | 619 12.8 15.5 22.0 | 221 8.5 11.3 15.9 | 723 13.7 16.8 23.8 | 258 9.8 12.2 17.1 | 826 14.6 18.0 25.6 | 295 10.7 12.8 18.3 | 929 15.5 19.2 27.1 | 332 11.3 13.7 19.5 |
| | SH4R | l/s per side Throw (m) 1 2 3 | 210 6.1 9.1 12.8 | 55 4.0 6.1 10.1 | 280 8.2 10.7 14.9 | 74 5.5 8.2 11.6 | 350 9.5 11.9 16.8 | 92 7.0 9.1 12.8 | 421 10.7 12.8 18.3 | 110 8.2 10.1 14.3 | 490 11.3 14.0 19.8 | 129 8.8 10.7 15.2 | 560 12.2 14.9 21.3 | 148 9.5 11.6 16.5 | 631 12.8 15.9 22.6 | 166 10.1 12.2 17.4 |

| | | Total l/s NC Side | 372 13 | | 496 20 | | 620 26 | | 743 31 | | 868 35 | | 991 39 | | 1 115 42 | |
|-------------------------|------|---------------------------------------|----------------------------|---------------------------|----------------------------|---------------------------|-----------------------------|---------------------------|-----------------------------|---------------------------|-----------------------------|----------------------------|-----------------------------|----------------------------|-------------------------------|----------------------------|
| | | | A | B | A | B | A | B | A | B | A | B | A | B | A | B |
| 450 X 525 | SH1 | l/s per side Throw (m) 1 2 3 | 372 8.2 10.4 14.6 | | 496 9.8 11.9 16.8 | | 620 10.7 13.4 18.9 | | 743 11.9 14.6 20.7 | | 868 12.8 15.9 22.3 | | 991 13.7 16.8 23.8 | | 1 115 14.6 18.0 25.3 | |
| | SH2 | l/s per side Throw (m) 1 2 3 | 186 4.6 6.7 11.9 | | 248 6.1 9.1 13.7 | | 310 7.6 11.0 15.5 | | 372 9.1 11.9 17.1 | | 434 10.7 12.8 18.3 | | 496 11.3 13.7 19.5 | | 557 11.9 14.6 20.7 | |
| | SHD2 | l/s per side Throw (m) 1 2 3 | 212 5.8 7.9 11.3 | 160 3.4 5.2 11.3 | 283 7.6 9.1 13.1 | 212 4.6 7.0 10.7 | 354 8.5 10.4 14.6 | 266 5.8 8.5 12.2 | 425 9.1 11.3 16.2 | 319 7.0 9.5 13.1 | 496 10.1 12.2 17.4 | 372 8.2 10.1 14.3 | 566 10.7 13.1 18.6 | 425 8.8 10.7 15.2 | 637 11.3 14.0 19.8 | 478 9.5 11.6 16.2 |
| | SH3S | l/s per side Throw (m) 1 2 3 | 146 5.2 7.6 10.7 | 80 3.4 5.2 8.2 | 195 6.7 8.8 12.5 | 106 4.6 6.7 9.8 | 244 7.9 9.8 14.0 | 133 5.8 7.6 10.7 | 292 8.8 10.7 15.2 | 159 6.7 8.2 11.9 | 341 9.5 11.6 16.5 | 185 7.3 9.1 12.8 | 389 10.1 12.5 17.7 | 212 7.9 9.8 13.7 | 438 10.7 13.1 18.9 | 239 8.2 10.4 14.6 |
| | SH3L | l/s per side Throw (m) 1 2 3 | 109 4.9 7.3 11.9 | 132 3.4 5.2 9.5 | 145 6.4 9.8 13.7 | 176 4.6 7.0 10.7 | 181 8.2 11.0 15.2 | 219 5.8 8.5 12.2 | 217 9.8 11.9 16.8 | 263 7.0 9.5 13.1 | 253 10.4 12.8 18.3 | 307 8.2 10.1 14.3 | 289 11.3 13.7 19.5 | 351 8.8 10.7 15.2 | 326 11.9 14.6 20.7 | 395 9.5 11.6 16.2 |
| | SH4R | l/s per side Throw (m) 1 2 3 | 106 5.2 7.6 10.7 | 80 3.4 5.2 8.2 | 142 6.7 8.8 12.5 | 106 4.6 6.7 9.8 | 177 7.9 9.8 14.0 | 133 5.8 7.6 10.7 | 212 8.8 10.7 15.2 | 159 6.7 8.2 11.9 | 248 9.5 11.6 16.5 | 185 7.3 9.1 12.8 | 284 10.1 12.5 17.7 | 212 7.9 9.8 13.7 | 319 10.7 13.1 18.9 | 239 8.2 10.4 14.6 |

Performance Data

SH Rectangular Diffusers

| Nominal Size (mm) | Air Pattern (viewed from neck) | Neck Vel. (m/s) | 1.5 | 2.0 | 2.5 | 3.0 | 3.5 | 4.0 | 4.5 |
|-------------------|--------------------------------|-------------------|-----|-----|-----|-----|-----|-----|-----|
| | | Total Press. (Pa) | 11 | 19 | 29 | 42 | 57 | 75 | 94 |

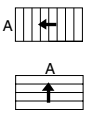
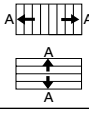
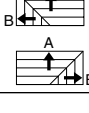
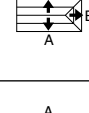
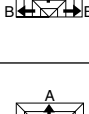
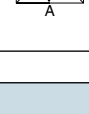
| Nominal Size (mm) | Air Pattern (viewed from neck) | Total l/s NC Side | 425 | | 566 | | 708 | | 850 | | 991 | | 1 133 | | 1 274 | |
|-------------------|--|---------------------------------------|----------------------------|---------------------------|-----------------------------|---------------------------|-----------------------------|---------------------------|-----------------------------|----------------------------|-----------------------------|----------------------------|-------------------------------|----------------------------|-------------------------------|-----------------------------|
| | | | 13 | | 21 | | 27 | | 31 | | 36 | | 39 | | 42 | |
| | | | A | B | A | B | A | B | A | B | A | B | A | B | A | B |
| 450 X 600 | SH1  | I/s per side Throw (m) 1 2 3 | 425 8.8 11.0 15.5 | | 566 10.4 12.8 18.0 | | 708 11.6 14.3 20.1 | | 850 12.8 15.5 22.0 | | 991 13.7 16.8 23.8 | | 1 133 14.6 18.0 25.6 | | 1 274 15.5 19.2 27.1 | |
| | SH2  | I/s per side Throw (m) 1 2 3 | 212 4.9 7.3 12.8 | | 283 6.4 9.8 14.9 | | 354 8.2 11.6 16.5 | | 425 9.8 12.8 18.3 | | 496 11.3 13.7 19.5 | | 566 12.2 14.9 21.0 | | 637 12.8 15.9 22.3 | |
| | SHD2  | I/s per side Throw (m) 1 2 3 | 266 6.1 8.5 12.2 | 160 3.7 5.5 10.1 | 354 7.9 9.8 14.0 | 212 4.9 7.6 11.6 | 443 9.1 11.0 15.5 | 266 6.1 9.1 12.8 | 531 9.8 12.2 17.1 | 319 7.6 10.1 14.0 | 620 10.7 13.1 18.6 | 372 8.8 10.7 15.2 | 708 11.3 14.0 19.8 | 425 9.5 11.6 16.5 | 797 12.2 14.9 21.0 | 478 10.1 12.2 17.4 |
| | SH3S  | I/s per side Throw (m) 1 2 3 | 172 5.5 8.2 11.6 | 80 3.7 5.5 8.8 | 230 7.3 9.5 13.4 | 107 4.9 7.3 10.4 | 287 8.5 10.7 14.9 | 133 6.1 8.2 11.6 | 345 9.5 11.6 16.5 | 160 7.3 8.8 12.8 | 403 10.1 12.5 17.7 | 186 7.9 9.8 13.7 | 460 11.0 13.4 18.9 | 213 8.5 10.4 14.6 | 517 11.6 14.0 20.1 | 240 8.8 11.0 15.5 |
| | SH3L  | I/s per side Throw (m) 1 2 3 | 142 5.2 7.9 12.8 | 142 3.7 5.5 10.1 | 189 7.0 10.4 14.6 | 189 4.9 7.6 11.6 | 236 8.8 11.6 16.5 | 236 6.1 9.1 12.8 | 283 10.4 12.8 18.0 | 283 7.6 10.1 14.0 | 330 11.3 13.7 19.5 | 330 8.8 10.7 15.2 | 377 11.9 14.6 20.7 | 377 9.5 11.6 16.5 | 424 12.8 15.5 22.3 | 424 10.1 12.2 17.4 |
| | SH4R  | I/s per side Throw (m) 1 2 3 | 133 5.5 8.2 11.6 | 80 3.7 5.5 8.8 | 177 7.3 9.5 13.4 | 107 4.9 7.3 10.4 | 222 8.5 10.7 14.9 | 133 6.1 8.2 11.6 | 266 9.5 11.6 16.5 | 160 7.3 8.8 12.8 | 310 10.1 12.5 17.7 | 186 7.9 9.8 13.7 | 354 11.0 13.4 18.9 | 213 8.5 10.4 14.6 | 399 11.6 14.0 20.1 | 240 8.8 11.0 15.5 |

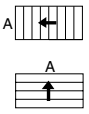
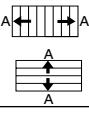
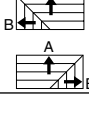
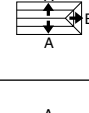
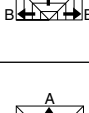
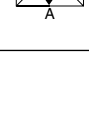
| Nominal Size (mm) | Air Pattern (viewed from neck) | Total l/s NC Side | 531 | | 708 | | 885 | | 1 062 | | 1 239 | | 1 416 | | 1 593 | |
|-------------------|--|---------------------------------------|-----------------------------|---------------------------|-----------------------------|---------------------------|-----------------------------|----------------------------|-------------------------------|----------------------------|-------------------------------|----------------------------|-------------------------------|-----------------------------|-------------------------------|-----------------------------|
| | | | 14 | | 22 | | 27 | | 32 | | 36 | | 40 | | 43 | |
| | | | A | B | A | B | A | B | A | B | A | B | A | B | A | B |
| 450 X 750 | SH1  | I/s per side Throw (m) 1 2 3 | 531 10.1 12.2 17.4 | | 708 11.6 14.3 20.1 | | 885 12.8 15.9 22.6 | | 1 062 14.3 17.4 24.7 | | 1 239 15.2 18.9 26.8 | | 1 416 16.5 20.1 28.7 | | 1 593 17.4 21.3 30.2 | |
| | SH2  | I/s per side Throw (m) 1 2 3 | 266 5.5 8.2 14.3 | | 354 7.3 11.0 16.5 | | 443 9.1 13.1 18.6 | | 531 11.0 14.3 20.4 | | 620 12.5 15.5 22.0 | | 708 13.4 16.5 23.5 | | 797 14.3 17.7 25.0 | |
| | SHD2  | I/s per side Throw (m) 1 2 3 | 372 7.0 9.5 13.7 | 160 4.3 6.4 11.3 | 496 9.1 11.0 15.5 | 212 5.5 8.5 12.8 | 620 10.1 12.5 17.7 | 266 7.0 10.1 14.3 | 743 11.0 13.7 19.2 | 319 8.5 11.3 15.9 | 868 11.9 14.6 20.7 | 372 9.8 12.2 17.1 | 991 12.8 15.5 22.3 | 425 10.7 12.8 18.3 | 1 115 13.7 16.8 23.5 | 478 11.3 13.7 19.5 |
| | SH3S  | I/s per side Throw (m) 1 2 3 | 226 6.1 9.1 12.8 | 80 4.0 6.1 10.1 | 301 8.2 10.7 14.9 | 106 5.5 8.2 11.6 | 376 9.5 11.9 16.8 | 133 7.0 9.1 12.8 | 451 10.7 12.8 18.3 | 160 8.2 10.1 14.3 | 527 11.3 14.0 19.8 | 186 8.8 10.7 15.2 | 602 12.2 14.9 21.3 | 212 9.5 11.6 16.5 | 677 12.8 15.9 22.6 | 239 10.1 12.2 17.4 |
| | SH3L  | I/s per side Throw (m) 1 2 3 | 221 5.8 8.8 14.3 | 155 4.3 6.4 11.3 | 295 7.9 11.6 16.5 | 207 5.5 8.5 12.8 | 369 9.8 13.1 18.3 | 259 7.0 10.1 14.3 | 443 11.6 14.3 20.1 | 310 8.5 11.3 15.9 | 517 12.5 15.2 22.0 | 362 9.8 12.2 17.1 | 590 13.4 16.5 23.2 | 413 10.7 12.8 18.3 | 664 14.3 17.4 24.7 | 465 11.3 13.7 19.5 |
| | SH4R  | I/s per side Throw (m) 1 2 3 | 186 6.1 9.1 12.8 | 80 4.0 6.1 10.1 | 248 8.2 10.7 14.9 | 106 5.5 8.2 11.6 | 310 9.5 11.9 16.8 | 133 7.0 9.1 12.8 | 372 10.7 12.8 18.3 | 160 8.2 10.1 14.3 | 434 11.3 14.0 19.8 | 186 8.8 10.7 15.2 | 496 12.2 14.9 21.3 | 212 9.5 11.6 16.5 | 557 12.8 15.9 22.6 | 239 10.1 12.2 17.4 |

Performance Data

SH Rectangular Diffusers

| Nominal Size (mm) | Air Pattern (viewed from neck) | Neck Vel. (m/s) Total Press. (Pa) | 1.5 | 2.0 | 2.5 | 3.0 | 3.5 | 4.0 | 4.5 |
|-------------------|--------------------------------|--------------------------------------|-----|-----|-----|-----|-----|-----|-----|
| | | | 11 | 19 | 29 | 42 | 57 | 75 | 94 |

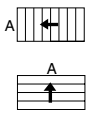
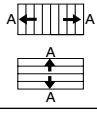
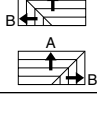
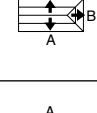
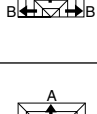
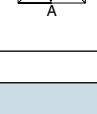
| | | Total l/s NC Side | 637 15 | | 850 22 | | 1 062 28 | | 1 274 33 | | 1 487 37 | | 1 699 40 | | 1 912 43 | |
|-------------------------|--|---------------------------------------|-----------------------------|---------------------------|-----------------------------|---------------------------|-------------------------------|----------------------------|-------------------------------|----------------------------|-------------------------------|-----------------------------|-------------------------------|-----------------------------|-------------------------------|-----------------------------|
| | | | A | B | A | B | A | B | A | B | A | B | A | B | A | B |
| 450 X 900 | SH1  | l/s per side Throw (m) 1 2 3 | 637 11.0 13.4 19.2 | | 850 12.8 15.5 22.0 | | 1 062 14.3 17.4 24.7 | | 1 274 15.5 19.2 27.1 | | 1 487 16.8 20.7 29.3 | | 1 699 18.0 22.0 31.4 | | 1 912 19.2 23.5 33.2 | |
| | SH2  | l/s per side Throw (m) 1 2 3 | 319 5.8 8.8 15.9 | | 425 7.9 11.9 18.3 | | 531 10.1 14.3 20.4 | | 637 11.9 15.9 22.3 | | 743 13.7 17.1 24.1 | | 850 14.9 18.3 25.9 | | 956 15.9 19.2 27.4 | |
| | SHD2  | l/s per side Throw (m) 1 2 3 | 478 7.6 10.4 14.9 | 160 4.6 7.0 12.2 | 637 9.8 12.2 17.1 | 212 6.1 9.1 14.0 | 797 11.0 13.7 19.2 | 266 7.6 11.3 15.9 | 956 12.2 14.9 21.0 | 319 9.1 12.2 17.4 | 1 115 13.1 16.2 22.9 | 372 10.7 13.1 18.9 | 1 274 14.0 17.1 24.4 | 425 11.6 14.0 20.1 | 1 434 14.9 18.3 25.9 | 478 12.2 14.9 21.3 |
| | SH3S  | l/s per side Throw (m) 1 2 3 | 279 6.7 10.1 14.0 | 80 4.6 6.7 11.0 | 372 8.8 11.6 16.5 | 106 6.1 8.8 12.8 | 465 10.7 12.8 18.3 | 133 7.6 10.1 14.3 | 558 11.6 14.0 20.1 | 160 8.8 11.0 15.5 | 651 12.5 15.2 21.6 | 186 9.8 11.9 16.8 | 744 13.4 16.5 23.2 | 212 10.4 12.8 18.0 | 837 14.0 17.4 24.7 | 239 11.0 13.4 19.2 |
| | SH3L  | l/s per side Throw (m) 1 2 3 | 319 8.5 11.9 16.8 | 160 4.6 7.0 12.2 | 425 11.3 13.7 19.5 | 212 6.1 9.1 14.0 | 531 12.5 15.2 22.0 | 266 7.6 11.3 15.9 | 637 13.7 16.8 23.8 | 319 9.1 12.2 17.4 | 743 14.9 18.3 25.9 | 372 10.7 13.1 18.9 | 850 15.9 19.5 27.7 | 425 11.6 14.0 20.1 | 956 16.8 20.7 29.3 | 478 12.2 14.9 21.3 |
| | SH4R  | l/s per side Throw (m) 1 2 3 | 239 6.7 10.1 14.0 | 80 4.6 6.7 11.0 | 319 8.8 11.6 16.5 | 106 6.1 8.8 12.8 | 398 10.7 12.8 18.3 | 133 7.6 10.1 14.3 | 478 11.6 14.0 20.1 | 160 8.8 11.0 15.5 | 557 12.5 15.2 21.6 | 186 9.8 11.9 16.8 | 637 13.4 16.5 23.2 | 212 10.4 12.8 18.0 | 717 14.0 17.4 24.7 | 239 11.0 13.4 19.2 |

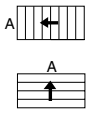
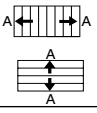
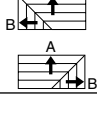
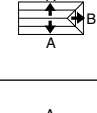
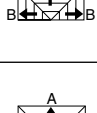
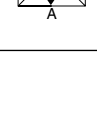
| | | Total l/s NC Side | 496 14 | | 661 21 | | 826 27 | | 991 32 | | 1 156 36 | | 1 322 40 | | 1 487 43 | |
|-------------------------|--|---------------------------------------|----------------------------|---------------------------|-----------------------------|---------------------------|-----------------------------|---------------------------|-----------------------------|----------------------------|-------------------------------|----------------------------|-------------------------------|-----------------------------|-------------------------------|-----------------------------|
| | | | A | B | A | B | A | B | A | B | A | B | A | B | A | B |
| 525 X 600 | SH1  | l/s per side Throw (m) 1 2 3 | 496 9.8 11.9 16.8 | | 661 11.3 13.7 19.5 | | 826 12.5 15.2 21.6 | | 991 13.7 16.8 23.8 | | 1 156 14.9 18.3 25.9 | | 1 322 15.9 19.5 27.4 | | 1 487 16.8 20.7 29.3 | |
| | SH2  | l/s per side Throw (m) 1 2 3 | 248 5.2 7.9 13.7 | | 330 7.0 10.7 16.2 | | 413 8.8 12.5 18.0 | | 496 10.7 13.7 19.5 | | 578 12.2 14.9 21.3 | | 661 13.1 16.2 22.6 | | 743 13.7 17.1 24.1 | |
| | SHD2  | l/s per side Throw (m) 1 2 3 | 279 6.7 9.1 13.1 | 217 4.0 6.1 10.7 | 372 8.5 10.7 15.2 | 289 5.5 8.2 12.5 | 464 9.8 11.9 17.1 | 362 6.7 9.8 14.0 | 557 10.7 13.1 18.6 | 434 8.2 10.7 15.2 | 650 11.6 14.0 20.1 | 506 9.5 11.6 16.5 | 743 12.5 15.2 21.6 | 578 10.1 12.5 17.7 | 836 13.1 16.2 22.9 | 650 10.7 13.1 18.9 |
| | SH3S  | l/s per side Throw (m) 1 2 3 | 194 5.8 8.8 12.5 | 109 4.0 6.1 9.8 | 258 7.9 10.1 14.3 | 145 5.2 7.9 11.3 | 323 9.1 11.3 16.2 | 181 6.7 8.8 12.5 | 388 10.1 12.5 17.7 | 217 7.9 9.8 13.7 | 452 11.0 13.4 19.2 | 253 8.5 10.4 14.9 | 517 11.9 14.3 20.4 | 289 9.1 11.3 15.9 | 582 12.5 15.2 21.6 | 326 9.8 11.9 16.8 |
| | SH3L  | l/s per side Throw (m) 1 2 3 | 142 5.5 8.5 13.7 | 177 4.0 6.1 10.7 | 189 7.6 11.3 15.9 | 236 5.5 8.2 12.5 | 236 9.5 12.5 17.7 | 295 6.7 9.8 14.0 | 284 11.3 13.7 19.5 | 354 8.2 10.7 15.2 | 331 12.2 14.9 21.0 | 413 9.5 11.6 16.5 | 378 12.8 15.9 22.6 | 472 10.1 12.5 17.7 | 425 13.7 16.8 23.8 | 531 10.7 13.1 18.9 |
| | SH4R  | l/s per side Throw (m) 1 2 3 | 139 5.8 8.8 12.5 | 109 4.0 6.1 9.8 | 185 7.9 10.1 14.3 | 145 5.2 7.9 11.3 | 232 9.1 11.3 16.2 | 181 6.7 8.8 12.5 | 278 10.1 12.5 17.7 | 217 7.9 9.8 13.7 | 325 11.0 13.4 19.2 | 253 8.5 10.4 14.9 | 371 11.9 14.3 20.4 | 289 9.1 11.3 15.9 | 418 12.5 15.2 21.6 | 326 9.8 11.9 16.8 |

Performance Data

SH Rectangular Diffusers

| Nominal Size (mm) | Air Pattern (viewed from neck) | Neck Vel. (m/s) | 1.5 | 2.0 | 2.5 | 3.0 | 3.5 | 4.0 | 4.5 |
|-------------------|--------------------------------|-------------------|-----|-----|-----|-----|-----|-----|-----|
| | | Total Press. (Pa) | 11 | 19 | 29 | 42 | 57 | 75 | 94 |

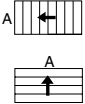
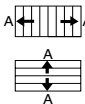
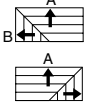
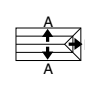
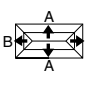
| | | Total l/s NC Side | 620 | | 826 | | 1 033 | | 1 239 | | 1 446 | | 1 652 | | 1 859 | |
|--|---|-------------------|------|------|------|------|-------|------|-------|------|-------|-------|-------|-------|-------|-----|
| | | | 15 | A B | 22 | A B | 28 | A B | 33 | A B | 37 | A B | 40 | A B | 43 | A B |
| 525 X 750 | SH1  | l/s per side | 620 | | 826 | | 1 033 | | 1 239 | | 1 446 | | 1 652 | | 1 859 | |
| | | Throw (m) 1 | 10.7 | | 12.5 | | 14.0 | | 15.2 | | 16.5 | | 17.7 | | 18.9 | |
| | | 2 | 13.4 | | 15.2 | | 17.1 | | 18.9 | | 20.4 | | 21.6 | | 23.2 | |
| | | 3 | 18.9 | | 21.6 | | 26.8 | | 26.8 | | 29.0 | | 30.8 | | 32.6 | |
| | SH2  | l/s per side | 310 | | 413 | | 516 | | 620 | | 723 | | 826 | | 929 | |
| | | Throw (m) 1 | 5.8 | | 7.9 | | 9.8 | | 11.9 | | 13.7 | | 14.6 | | 15.5 | |
| | 2 | 8.8 | | 11.9 | | 14.0 | | 15.5 | | 16.8 | | 18.0 | | 18.9 | | |
| | 3 | 15.5 | | 18.0 | | 20.1 | | 22.0 | | 23.8 | | 25.3 | | 26.8 | | |
| SHD2  | l/s per side | 403 | 217 | 537 | 289 | 671 | 362 | 805 | 434 | 940 | 506 | 1 074 | 578 | 1 208 | 650 | |
| | Throw (m) 1 | 7.6 | 4.6 | 9.8 | 6.1 | 11.0 | 7.6 | 11.9 | 9.1 | 12.8 | 10.7 | 13.7 | 11.3 | 14.6 | 12.2 | |
| | 2 | 10.4 | 6.7 | 11.9 | 9.1 | 13.4 | 11.0 | 14.6 | 12.2 | 15.9 | 13.1 | 17.1 | 14.0 | 18.0 | 14.9 | |
| | 3 | 14.6 | 12.2 | 17.1 | 14.0 | 18.9 | 15.5 | 20.7 | 17.1 | 22.6 | 18.6 | 24.1 | 19.8 | 25.6 | 21.0 | |
| SH3S  | l/s per side | 256 | 109 | 341 | 144 | 426 | 181 | 512 | 217 | 597 | 253 | 683 | 289 | 767 | 325 | |
| | Throw (m) 1 | 6.7 | 4.3 | 8.8 | 5.8 | 10.4 | 7.3 | 11.3 | 8.8 | 12.2 | 9.5 | 13.1 | 10.1 | 14.0 | 10.7 | |
| | 2 | 9.8 | 6.7 | 11.3 | 8.8 | 12.8 | 9.8 | 14.0 | 10.7 | 15.2 | 11.6 | 16.2 | 12.5 | 17.1 | 13.1 | |
| | 3 | 14.0 | 10.7 | 16.2 | 12.5 | 18.0 | 14.0 | 19.8 | 15.2 | 21.3 | 16.5 | 22.9 | 17.7 | 24.4 | 18.9 | |
| SH3L  | l/s per side | 221 | 199 | 295 | 265 | 369 | 331 | 442 | 398 | 516 | 464 | 590 | 531 | 664 | 597 | |
| | Throw (m) 1 | 6.4 | 4.6 | 8.5 | 6.1 | 10.7 | 7.6 | 12.5 | 9.1 | 13.4 | 10.7 | 14.6 | 11.3 | 15.2 | 12.2 | |
| | 2 | 9.5 | 6.7 | 12.5 | 9.1 | 14.0 | 11.0 | 15.2 | 12.2 | 16.8 | 13.1 | 17.7 | 14.0 | 18.9 | 14.9 | |
| | 3 | 15.2 | 12.2 | 17.7 | 14.0 | 19.8 | 15.5 | 22.0 | 17.1 | 23.5 | 18.6 | 25.3 | 19.8 | 26.8 | 21.0 | |
| SH4R  | l/s per side | 202 | 109 | 269 | 144 | 336 | 181 | 403 | 217 | 470 | 253 | 537 | 289 | 604 | 325 | |
| | Throw (m) 1 | 6.7 | 4.3 | 8.8 | 5.8 | 10.4 | 7.3 | 11.3 | 8.8 | 12.2 | 9.5 | 13.1 | 10.1 | 14.0 | 10.7 | |
| | 2 | 9.8 | 6.7 | 11.3 | 8.8 | 12.8 | 9.8 | 14.0 | 10.7 | 15.2 | 11.6 | 16.2 | 12.5 | 17.1 | 13.1 | |
| | 3 | 14.0 | 10.7 | 16.2 | 12.5 | 18.0 | 14.0 | 19.8 | 15.2 | 21.3 | 16.5 | 22.9 | 17.7 | 24.4 | 18.9 | |

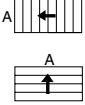
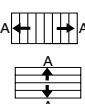
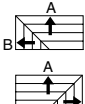
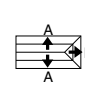
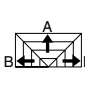
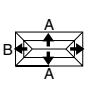
| | | Total l/s NC Side | 743 | | 991 | | 1 239 | | 1 487 | | 1 735 | | 1 982 | | 2 230 | |
|--|---|-------------------|------|------|------|------|-------|-------|-------|-------|-------|-------|-------|-------|-------|-----|
| | | | 15 | A B | 23 | A B | 29 | A B | 33 | A B | 37 | A B | 41 | A B | 44 | A B |
| 525 X 900 | SH1  | l/s per side | 743 | | 991 | | 1 239 | | 1 487 | | 1 735 | | 1 982 | | 2 230 | |
| | | Throw (m) 1 | 11.9 | | 13.7 | | 15.2 | | 16.8 | | 18.3 | | 19.5 | | 20.7 | |
| | | 2 | 14.6 | | 16.8 | | 18.9 | | 20.7 | | 22.3 | | 23.8 | | 25.3 | |
| | | 3 | 20.7 | | 23.8 | | 26.8 | | 29.3 | | 31.7 | | 33.8 | | 36.0 | |
| | SH2  | l/s per side | 372 | | 496 | | 620 | | 743 | | 868 | | 991 | | 1 115 | |
| | | Throw (m) 1 | 6.4 | | 8.5 | | 10.7 | | 13.1 | | 14.9 | | 16.2 | | 17.1 | |
| | 2 | 9.8 | | 13.1 | | 15.5 | | 17.1 | | 18.3 | | 19.5 | | 20.7 | | |
| | 3 | 17.1 | | 19.5 | | 22.0 | | 24.1 | | 25.9 | | 27.7 | | 29.6 | | |
| SHD2  | l/s per side | 527 | 217 | 702 | 289 | 877 | 362 | 1 053 | 434 | 1 229 | 506 | 1 404 | 578 | 1 580 | 650 | |
| | Throw (m) 1 | 8.2 | 4.9 | 10.7 | 6.7 | 11.9 | 8.2 | 13.1 | 10.1 | 14.0 | 11.6 | 15.2 | 12.5 | 16.2 | 13.1 | |
| | 2 | 11.3 | 7.3 | 13.1 | 10.1 | 14.6 | 12.2 | 16.2 | 13.1 | 17.4 | 14.3 | 18.6 | 15.2 | 19.8 | 16.2 | |
| | 3 | 16.2 | 13.1 | 18.6 | 15.2 | 20.7 | 17.1 | 22.9 | 18.9 | 24.7 | 20.4 | 26.2 | 21.6 | 28.0 | 23.2 | |
| SH3S  | l/s per side | 318 | 109 | 423 | 145 | 529 | 181 | 635 | 217 | 741 | 253 | 846 | 289 | 952 | 326 | |
| | Throw (m) 1 | 7.3 | 4.9 | 9.8 | 6.4 | 11.3 | 8.2 | 12.5 | 9.8 | 13.4 | 10.4 | 14.3 | 11.3 | 15.2 | 11.9 | |
| | 2 | 10.7 | 7.3 | 12.5 | 9.8 | 14.0 | 10.7 | 15.2 | 11.9 | 16.5 | 12.8 | 17.7 | 13.7 | 18.9 | 14.6 | |
| | 3 | 15.2 | 11.9 | 17.7 | 13.7 | 19.8 | 15.2 | 21.6 | 16.8 | 23.5 | 18.3 | 25.0 | 19.5 | 26.5 | 20.7 | |
| SH3L  | l/s per side | 319 | 212 | 425 | 284 | 531 | 354 | 638 | 425 | 744 | 496 | 851 | 567 | 957 | 638 | |
| | Throw (m) 1 | 7.0 | 4.9 | 9.1 | 6.7 | 11.5 | 8.2 | 13.7 | 10.1 | 14.9 | 11.6 | 15.9 | 12.5 | 16.8 | 13.1 | |
| | 2 | 10.4 | 7.3 | 13.7 | 10.1 | 15.2 | 12.2 | 16.8 | 13.1 | 18.3 | 14.3 | 19.5 | 15.2 | 20.7 | 16.2 | |
| | 3 | 16.8 | 13.1 | 19.5 | 15.2 | 22.0 | 17.1 | 23.8 | 18.9 | 25.9 | 20.4 | 27.7 | 21.6 | 29.3 | 23.2 | |
| SH4R  | l/s per side | 263 | 109 | 351 | 145 | 438 | 181 | 526 | 217 | 614 | 253 | 702 | 289 | 790 | 326 | |
| | Throw (m) 1 | 7.3 | 4.9 | 9.8 | 6.4 | 11.3 | 8.2 | 12.5 | 9.8 | 13.4 | 10.4 | 14.3 | 11.3 | 15.2 | 11.9 | |
| | 2 | 10.7 | 7.3 | 12.5 | 9.8 | 14.0 | 10.7 | 15.2 | 11.9 | 16.5 | 12.8 | 17.7 | 13.7 | 18.9 | 14.6 | |
| | 3 | 15.2 | 11.9 | 17.7 | 13.7 | 19.8 | 15.2 | 21.6 | 16.8 | 23.5 | 18.3 | 25.0 | 19.5 | 26.5 | 20.7 | |

Performance Data

SH Rectangular Diffusers

| Nominal Size (mm) | Air Pattern (viewed from neck) | Neck Vel. (m/s) | 1.5 | 2.0 | 2.5 | 3.0 | 3.5 | 4.0 | 4.5 |
|-------------------|--------------------------------|-------------------|-----|-----|-----|-----|-----|-----|-----|
| | | Total Press. (Pa) | 11 | 19 | 29 | 42 | 57 | 75 | 94 |

| 600 | X | SH1 | SH2 | SHD2 | SH3S | SH3L | SH4R | Total l/s | 708 | 944 | 1 180 | 1 416 | 1 652 | 1 888 | 2 124 | | | | | | | | | | | | | | | | | |
|------|---|------|-----|------|------|------|------|--------------|-----------|--------------|-----------|-------|-------|-------|-------|-------|-------|------|-------|------|------|------|-------|------|-------|------|------|------|------|------|------|------|
| | | | | | | | | NC | 15 | | 23 | | 28 | | 33 | | 37 | | 41 | | 44 | | | | | | | | | | | |
| | | | | | | | | Side | A | B | A | B | A | B | A | B | A | B | A | B | A | B | | | | | | | | | | |
| 750 | X | SH1 | SH2 | SHD2 | SH3S | SH3L | SH4R | I/s per side | Throw (m) | 1 | 708 | 944 | 1 180 | 1 416 | 1 652 | 1 888 | 2 124 | | | | | | | | | | | | | | | |
| | | | | | | | | | | 2 | 11.6 | 13.4 | 14.9 | 16.5 | 17.7 | 18.9 | 20.1 | | | | | | | | | | | | | | | |
| | | | | | | | | | | 3 | 14.3 | 16.5 | 18.3 | 20.1 | 21.6 | 23.2 | 24.7 | | | | | | | | | | | | | | | |
| | | 900 | X | SH1 | SH2 | SHD2 | SH3S | SH3L | SH4R | I/s per side | Throw (m) | 1 | 354 | 472 | 590 | 708 | 826 | 944 | 1 062 | | | | | | | | | | | | | |
| | | | | | | | | | | | | 2 | 6.4 | 8.5 | 10.7 | 12.8 | 14.6 | 15.5 | 16.5 | | | | | | | | | | | | | |
| | | | | | | | | | | | | 3 | 9.5 | 12.8 | 15.2 | 16.5 | 18.0 | 19.2 | 20.4 | | | | | | | | | | | | | |
| 1200 | X | | | SH1 | SH2 | SHD2 | SH3S | SH3L | SH4R | I/s per side | Throw (m) | 1 | 425 | 283 | 566 | 378 | 708 | 472 | 850 | 566 | 991 | 661 | 1 133 | 755 | 1 274 | 850 | | | | | | |
| | | | | | | | | | | | | 2 | 7.9 | 4.9 | 10.4 | 6.4 | 11.6 | 8.2 | 12.8 | 9.8 | 13.7 | 11.3 | 14.9 | 12.2 | 17.1 | 14.0 | 18.3 | 14.9 | 15.5 | 12.8 | 15.5 | 12.8 |
| | | | | | | | | | | | | 3 | 11.0 | 7.3 | 12.8 | 9.8 | 14.3 | 11.9 | 15.5 | 12.8 | 17.1 | 14.0 | 18.3 | 14.9 | 15.5 | 12.8 | 17.1 | 14.0 | 18.3 | 14.9 | 15.5 | 12.8 |
| | | 1500 | X | SH1 | SH2 | SHD2 | SH3S | SH3L | SH4R | I/s per side | Throw (m) | 1 | 283 | 142 | 378 | 189 | 472 | 236 | 566 | 283 | 661 | 330 | 755 | 378 | 850 | 425 | | | | | | |
| | | | | | | | | | | | | 2 | 7.0 | 4.9 | 9.5 | 6.4 | 11.0 | 7.9 | 12.2 | 9.5 | 13.1 | 10.1 | 14.0 | 11.0 | 14.9 | 11.6 | 16.2 | 12.5 | 17.4 | 13.4 | 18.3 | 14.3 |
| | | | | | | | | | | | | 3 | 10.7 | 7.3 | 12.2 | 10.4 | 13.7 | 10.7 | 14.9 | 11.6 | 16.2 | 12.5 | 17.4 | 13.4 | 18.3 | 14.9 | 15.5 | 12.8 | 17.7 | 14.0 | 18.9 | 15.5 |
| 1800 | X | | | SH1 | SH2 | SHD2 | SH3S | SH3L | SH4R | I/s per side | Throw (m) | 1 | 221 | 244 | 295 | 325 | 369 | 406 | 443 | 487 | 516 | 568 | 590 | 649 | 664 | 730 | | | | | | |
| | | | | | | | | | | | | 2 | 6.7 | 4.9 | 9.1 | 6.4 | 11.3 | 8.2 | 13.4 | 9.8 | 14.6 | 11.3 | 15.5 | 12.2 | 16.5 | 12.8 | 17.7 | 14.0 | 18.9 | 14.9 | 15.9 | |
| | | | | | | | | | | | | 3 | 10.4 | 7.3 | 13.4 | 9.8 | 14.9 | 11.9 | 16.5 | 12.8 | 17.7 | 14.0 | 18.9 | 14.9 | 15.9 | 12.8 | 17.7 | 14.0 | 18.9 | 14.9 | 15.9 | |
| | | 2100 | X | SH1 | SH2 | SHD2 | SH3S | SH3L | SH4R | I/s per side | Throw (m) | 1 | 212 | 142 | 283 | 189 | 354 | 236 | 425 | 283 | 496 | 330 | 566 | 378 | 637 | 425 | | | | | | |
| | | | | | | | | | | | | 2 | 7.0 | 4.9 | 9.5 | 6.4 | 11.0 | 7.9 | 12.2 | 9.5 | 13.1 | 10.1 | 14.0 | 11.0 | 14.9 | 11.6 | 16.2 | 12.5 | 17.4 | 13.4 | 18.3 | 14.3 |
| | | | | | | | | | | | | 3 | 10.7 | 7.3 | 12.2 | 10.4 | 13.7 | 10.7 | 14.9 | 11.6 | 16.2 | 12.5 | 17.4 | 13.4 | 18.3 | 14.9 | 15.5 | 12.8 | 17.7 | 14.0 | 18.9 | 15.5 |

| 600 | X | SH1 | SH2 | SHD2 | SH3S | SH3L | SH4R | Total l/s | 850 | 1 133 | 1 416 | 1 699 | 1 982 | 2 266 | 2 549 | | | | | | | | | | | | | | | | | |
|------|---|------|-----|------|------|------|------|--------------|-----------|--------------|-----------|-------|-------|-------|-------|-------|-------|-------|-------|------|-------|------|-------|------|-------|------|------|------|------|------|------|------|
| | | | | | | | | NC | 16 | | 23 | | 29 | | 34 | | 38 | | 41 | | 44 | | | | | | | | | | | |
| | | | | | | | | Side | A | B | A | B | A | B | A | B | A | B | A | B | A | B | | | | | | | | | | |
| 900 | X | SH1 | SH2 | SHD2 | SH3S | SH3L | SH4R | I/s per side | Throw (m) | 1 | 850 | 1 133 | 1 416 | 1 699 | 1 982 | 2 266 | 2 549 | | | | | | | | | | | | | | | |
| | | | | | | | | | | 2 | 12.8 | 14.6 | 16.5 | 18.0 | 19.5 | 20.7 | 22.0 | | | | | | | | | | | | | | | |
| | | | | | | | | | | 3 | 15.5 | 18.0 | 20.1 | 22.0 | 23.8 | 25.6 | 27.1 | | | | | | | | | | | | | | | |
| | | 1200 | X | SH1 | SH2 | SHD2 | SH3S | SH3L | SH4R | I/s per side | Throw (m) | 1 | 425 | 566 | 708 | 850 | 991 | 1 133 | 1 274 | | | | | | | | | | | | | |
| | | | | | | | | | | | | 2 | 7.0 | 9.1 | 11.6 | 14.0 | 16.2 | 17.1 | 18.3 | | | | | | | | | | | | | |
| | | | | | | | | | | | | 3 | 10.4 | 14.0 | 16.5 | 18.3 | 19.5 | 21.0 | 22.3 | | | | | | | | | | | | | |
| 1500 | X | | | SH1 | SH2 | SHD2 | SH3S | SH3L | SH4R | I/s per side | Throw (m) | 1 | 566 | 283 | 755 | 378 | 944 | 472 | 1 133 | 566 | 1 322 | 661 | 1 510 | 755 | 1 699 | 850 | | | | | | |
| | | | | | | | | | | | | 2 | 8.8 | 5.2 | 11.3 | 7.0 | 12.8 | 8.8 | 14.0 | 10.7 | 15.2 | 12.5 | 16.2 | 13.4 | 17.1 | 14.0 | 18.6 | 15.2 | 19.8 | 16.5 | 21.0 | 17.4 |
| | | | | | | | | | | | | 3 | 12.2 | 7.9 | 14.0 | 10.7 | 15.5 | 12.8 | 17.1 | 14.0 | 18.6 | 15.2 | 19.8 | 16.5 | 21.0 | 17.4 | 18.6 | 15.2 | 19.8 | 16.5 | 21.0 | 17.4 |
| | | 1800 | X | SH1 | SH2 | SHD2 | SH3S | SH3L | SH4R | I/s per side | Throw (m) | 1 | 354 | 142 | 472 | 189 | 590 | 236 | 708 | 283 | 826 | 330 | 944 | 378 | 1 062 | 425 | | | | | | |
| | | | | | | | | | | | | 2 | 7.6 | 5.2 | 10.4 | 7.0 | 12.2 | 8.8 | 13.4 | 10.4 | 14.3 | 11.3 | 15.5 | 11.9 | 18.9 | 14.6 | 20.1 | 15.5 | 15.5 | 12.8 | | |
| | | | | | | | | | | | | 3 | 11.6 | 7.9 | 13.4 | 10.4 | 14.9 | 11.6 | 16.5 | 12.8 | 17.7 | 13.7 | 18.9 | 14.6 | 20.1 | 15.5 | 15.5 | 12.8 | 17.7 | 13.7 | 18.9 | 14.6 |
| 2100 | X | | | SH1 | SH2 | SHD2 | SH3S | SH3L | SH4R | I/s per side | Throw (m) | 1 | 319 | 266 | 425 | 354 | 531 | 443 | 637 | 531 | 743 | 620 | 850 | 708 | 956 | 797 | | | | | | |
| | | | | | | | | | | | | 2 | 7.3 | 5.2 | 10.1 | 7.0 | 12.5 | 8.8 | 14.6 | 10.7 | 15.9 | 12.5 | 17.1 | 13.4 | 18.0 | 14.0 | 19.5 | 15.5 | 20.7 | 16.5 | 22.3 | 17.4 |
| | | | | | | | | | | | | 3 | 11.3 | 7.9 | 14.6 | 10.7 | 16.5 | 12.8 | 18.0 | 14.0 | 19.5 | 15.5 | 20.7 | 16.5 | 22.3 | 17.4 | 19.5 | 15.5 | 20.7 | 16.5 | 22.3 | 17.4 |
| | | 2400 | X | SH1 | SH2 | SHD2 | SH3S | SH3L | SH4R | I/s per side | Throw (m) | 1 | 283 | 142 | 378 | 189 | 472 | 236 | 566 | 283 | 661 | 330 | 755 | 378 | 850 | 425 | | | | | | |
| | | | | | | | | | | | | 2 | 7.6 | 5.2 | 10.4 | 7.0 | 12.2 | 8.8 | 13.4 | 10.4 | 14.3 | 11.3 | 15.5 | 11.9 | 18.9 | 14.6 | 20.1 | 15.5 | 15.5 | 12.8 | | |
| | | | | | | | | | | | | 3 | 11.6 | 7.9 | 13.4 | 10.4 | 14.9 | 11.6 | 16.5 | 12.8 | 17.7 | 13.7 | 18.9 | 14.6 | 20.1 | 15.5 | 15.5 | 12.8 | 17.7 | 13.7 | 18.9 | 14.6 |

ORDER EXAMPLES

Series & Air Pattern / Nominal Size

SH4 / 300 x 300

SH2S / 300 x 150

SHD2 / 300 x 300

SH4 / 300 x 300 / lay-in plaque

SH2S / 300 x 150 / OBD / lay-in plaque

Note: Nominal Sizes (mm):

Minimum: 150

Maximum: SH 900

SUGGESTED SPECIFICATION

SH Diffuser

Louvre type ceiling diffusers shall be of aluminium construction having removable cores. Core patterns shall be selected to suit the air distribution layout shown on the drawings. The removable cores shall be interchangeable within each size range. Diffusers shall be pre-treated, followed by gloss powder coating or enamel finish. Accessories must be purpose made for direct fitting to the diffusers.

Opposed Blade Dampers (OBDs) shall be of aluminium construction (mill finish) and shall be lever operated from the face of the diffuser.

ACCESSORIES

Opposed Blade Damper (OBD)

- Controls air volume for balancing and fine adjustment
- Installs directly to neck with clip fasteners
- Lever operated from the face of the grille/diffuser
- Not intended for use as a shut-off damper
- Aluminium construction
- Sized to suit grilles/diffusers

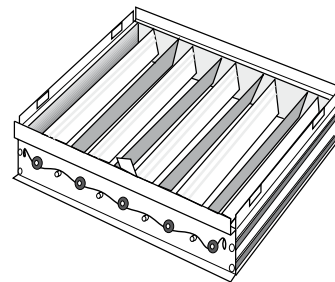
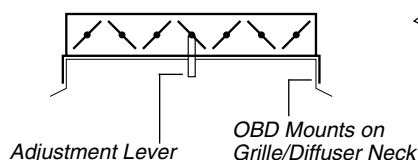

Square to Round Adaptor (SRA)

- Adapts square neck grilles/diffusers to round flexible or rigid ducting
- Black Satin enamel finish on inside surfaces
- Galvanised steel construction; black polyethylene construction for size 300 sq. to 200/250 round
- Sized to suit grilles/diffusers and ducting

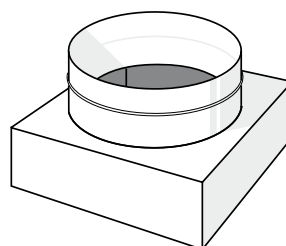

Side Entry/Exit Plenum (Cushion Head)

- Adapts square neck grilles/diffusers to round flexible or rigid ducting in a restricted ceiling space
- Uninsulated, or Insulated (25 mm) for improved acoustic and thermal properties
- Galvanised steel
- Sized to suit grilles/diffusers and ducting

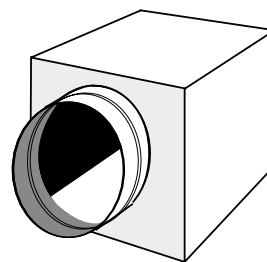

Plaque (PLQ)

- Provides rigid support for grille/diffuser installed in suspended tile ceilings
- Full or half tile sizes
- Supplied factory fitted to grille/diffuser
- Lay-in or set-down styles
- Powder coated electro-galvanised steel

