

**Ducted Split System
Air Conditioner**

Technical Data

ISD / OSA 330–460 RKT

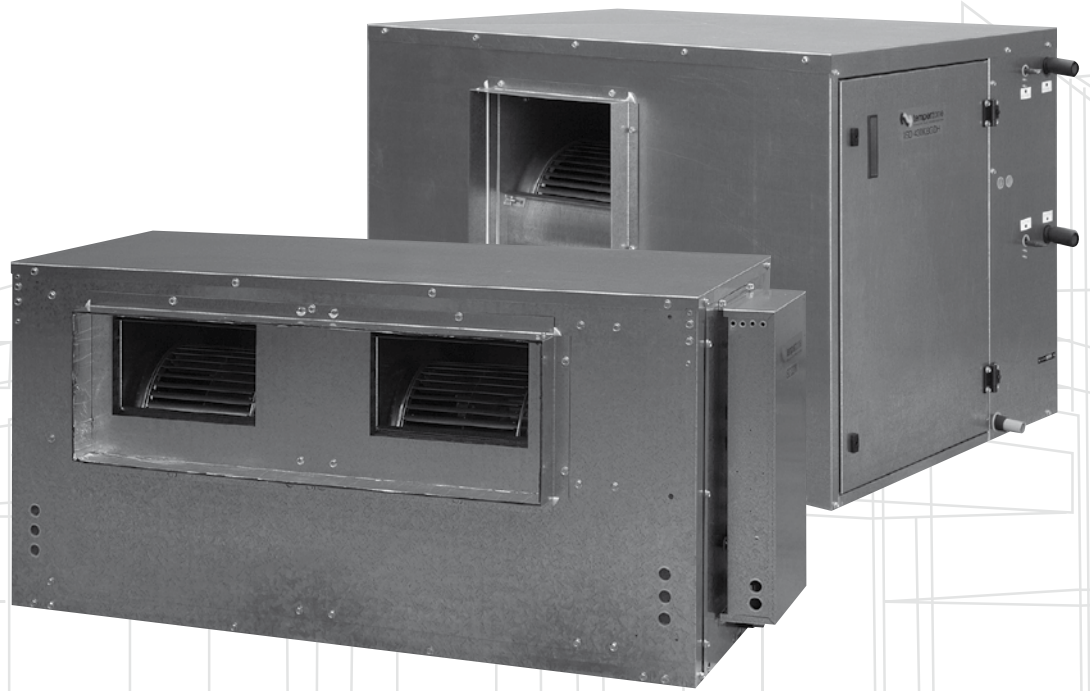

R410A

**Direct Drive or Belt Drive
Indoor Fan**

**Extra Long Life
Epoxy Coated Outdoor Coil**

**Nominal Cooling Capacity
33 kW – 46 kW**

ISD / OSA 330 - 460 – DUCTED SPLIT SYSTEM AIR CONDITIONERS

GENERAL

The ISD indoor unit, together with its associated OSA outdoor unit, provides a reverse cycle (heat pump) split system air conditioner designed and developed to comply with and exceed AS/NZS 3823 specified conditions (i.e. guaranteed cooling cycle performance at 43°C outdoor temperature).

Some indoor units are available with **belt drive** or **direct drive** fan.

APPLICATIONS

These units have been specifically developed for air conditioning of commercial premises, e.g. offices, motels, shops and restaurants.

Air Flow Selection

If the air returning to the indoor coil is regularly expected to be above 50%RH, then the coil face velocity should be limited to be 2.5 m/s or less (refer Air Handling graphs).

High humidity levels can occur in tropical or subtropical conditions, and/or when heavily moisture laden fresh air is introduced. Consideration must always be given to selecting an air flow and face velocity that avoids water carry-over problems.

Applications using full or high proportions of fresh air should be referred to your nearest **temperzone** sales office to establish the correct selection of units.

FEATURES

Refrigerant R410A. Each complete system uses refrigerant R410A which is deemed to have zero ozone depletion potential.

Efficient. The outdoor unit incorporates a high efficiency scroll compressor. Heat exchange coils incorporate inner grooved (rifled) tube for better heat transfer.

Economical. The ISD/OSA 430 system has two independent refrigeration circuits to provide the flexibility and economy of two stage operation, i.e. utilising one or two circuits as conditions vary, plus the advantage of staggered starting.

Performance. The ISD 330/460K models use a dynamically balanced forward curved fan with a multi-speed motor enables fine tuning of the indoor unit to match the supply air requirements. The ISD 331/406/430/461K models use an adjustable pulley driven indoor fan motor enables fine tuning of the indoor unit to match the supply air requirements. The system includes a temperature sensing head pressure control which enables the system to compensate for outdoor ambient temperatures below 20°C on cooling cycle, and above 15°C on heating cycle.

Quiet. The compressor is isolated in a built-in, insulated compartment to minimise noise. The indoor unit is also insulated for noise attenuation.

Durable. The outdoor coil fins are epoxy coated for extra protection in corrosive environments, e.g. salt laden sea air. The outdoor unit's cabinet is constructed from high grade galvanised steel - polyester powder coated (grey) for all weather protection (IP 45). External fasteners are stainless steel. Heat exchange coils comprise aluminium plate fins on mechanically expanded rifled copper tube. The indoor unit's cabinet is constructed from high grade galvanised steel and also includes a polyester powder coated drain tray.

Service Access. The indoor unit's built-in drain tray can be removed for ease of cleaning and service accessibility.

Insulation. Closed cell foam insulation has been used in the indoor unit's cabinet to ensure no particles are introduced into the air stream. The insulation is foil faced and meets fire test standards AS 1530.3 (1989) and BS 476 parts 6 & 7.

Mounting. The ISD 330/460K indoor units can be mounted rigid, or using the optional spring mounting brackets which minimise transfer of vibration.

Self Diagnostics. The Outdoor Unit Controller (OUC) has a display of LEDs to indicate faults and running conditions. A non-specific fault indicator is included for interface to external systems.

OPTIONAL EQUIPMENT

Outdoor Unit:

1. Anti-vibration mounts (rubber)
2. Drain connection - right angle

Indoor Unit:

temperzone TZT-701 Controller kit or SAT-2 (24V) Controller kit, latter of which is not suitable for digital systems.

ISD 330/460 K only:

1. Filter box - integrated return air spigot and washable polypropylene net filter.
2. Spring Mounting Kit.

ISD 331/406/430/461 K only:

1. Vertical supply air configuration.
2. Filters (rated EU4) integrated with return air spigot - four 50 mm deep pleated filters.

SAFETY FEATURES

1. HP and loss of refrigerant protection.
2. Anti-rapid cycle timer and internal overload for compressor protection.
3. Circuit breaker control circuits.
4. Time-and-temperature controlled electronic de-ice switch prevents icing up of the outdoor coil during heating cycle.
5. Frost protection on cooling cycle.
6. Sensor fault indication.
7. Compressor minimum run time to ensure oil return.

COMPRESSOR

Each high efficiency scroll type compressor is hermetically sealed, quiet running and supported on rubber mounts to minimise vibration.

REFRIGERATION PIPING

The standard unit allows for a line length up to 30 m. For line lengths between 30 m and 50 m, refer to **temperzone's** *Split Systems Installation Guide* (refer www.temperzone.biz/Technical Support).

Maximum line length when extended is 90m.

Max. height separations between units are :
Outdoor unit above indoor unit : 20 m
Outdoor unit below indoor unit : 20 m.

Each OSA is shipped from the factory with a holding charge of HFC-410A (R410A) refrigerant. Liquid and suction service valves are provided. Accurator expansion devices control the flow of refrigerant. The matched indoor unit is shipped with a holding charge of nitrogen. Both units have brazed pipe connections.

WIRING

The electrical supply required (including voltage fluctuation limits) is: 3 phase 342-436 V a.c. 50 Hz with neutral and earth.

The compressor crankcase heater requires a 24 hour power supply. A control panel, with 24V control circuit, is located in the outdoor unit and is fully wired ready to accept the main power supply.

OSA 430 Digital Version:

Digital Scroll Compressor. 'Digital' systems include one conventional scroll compressor and one digital scroll compressor. The digital version of this unit provides a variable capacity ability that enables closer control of room temperature. This is achieved by avoiding on/off cycling of the compressor. These compressors have proven very reliable because of their design simplicity. Electrical harmonic noise is very low.

Extended Capability. Digitals are particularly suitable for applications requiring full or high proportions of fresh air, VAV, close control and supply air temperature control.

Control Option. The system is set up for the compressor to be controlled variably by a 0-10 volt DC signal that can be supplied either by a BMS system, a sophisticated controller or temperzone's optional TZT-701 Controller.

The manufacturer operates a quality management system that conforms to AS/NZS ISO 9001:2008.

PERFORMANCE DATA

COOLING CAPACITY (kW)

Total = Total Capacity (kW) Sens. = Sensible Capacity (kW)
 E.A.T. = Entering Air Temperature ○ = Nominal Capacity (kW)
Note: Capacities are **gross** and do not include allowance for fan motor heat loss. Capacities are for close coupled systems. Interconnecting pipework will reduce capacity.

MODELS Indoor / Outdoor Unit	INDOOR FAN		INDOOR COIL E.A.T.		OUTDOOR COIL ENTERING AIR TEMPERATURE °C D.B.											
	SPEED	AIR l/s	W.B. °C	D.B. °C	23		27		31		35		39		43	
					Total	Sens.	Total	Sens.	Total	Sens.	Total	Sens.	Total	Sens.	Total	Sens.
ISD 330K / OSA 330RK	HIGH	1800	15	21	32.2	24.5	31.3	24.4	30.4	24.0	29.4	23.6	28.5	23.3	27.4	22.7
			17	23	33.8	24.9	33.2	24.4	32.2	24.0	31.3	23.6	30.4	23.3	29.4	22.8
			19	27	36.1	28.3	35.0	28.1	34.1	27.6	33.2	27.5	32.2	27.1	31.1	26.8
			21	31	38.1	32.2	37.0	31.8	36.1	31.4	35.2	31.2	34.1	30.9	33.0	30.5
ISD 331K / OSA 330RK	HIGH	1900	15	21	32.2	25.5	31.8	25.4	30.9	25.0	29.5	24.1	27.5	22.8	25.1	21.0
			17	23	33.9	24.9	33.5	24.9	32.6	24.5	31.2	23.7	29.2	22.5	26.8	20.9
			19	27	35.6	28.5	35.2	28.5	34.3	28.1	32.9	27.3	30.9	26.0	28.5	24.2
			21	31	37.3	33.7	36.9	33.8	36.0	33.4	34.6	32.4	32.6	31.0	30.2	29.0
ISD 406K / OSA 405RK	HIGH	2350	15	21	41.8	33.0	41.3	33.0	40.1	32.4	38.2	31.3	35.7	29.6	32.5	27.3
			17	23	44.0	32.3	43.5	32.3	42.3	31.8	40.4	30.7	37.9	29.2	34.7	27.1
			19	27	46.2	37.0	45.7	37.0	44.5	36.5	42.6	35.4	40.1	33.7	37.0	31.4
			21	31	48.4	43.8	47.9	43.8	46.7	43.3	44.8	42.1	42.3	40.2	39.1	37.6
ISD 430K / OSA 430RK	HIGH	2440	15	21	42.6	33.6	42.0	33.6	40.8	33.0	38.9	31.9	36.4	30.2	33.1	27.8
			17	23	44.8	32.9	44.3	32.9	43.1	32.4	41.2	31.3	38.6	29.7	35.4	27.6
			19	27	47.1	37.7	46.5	37.7	45.3	37.2	43.4	36.0	40.9	34.3	37.6	32.0
			21	31	49.3	44.6	48.8	44.7	47.6	44.1	45.7	42.8	43.1	40.9	39.9	38.3
ISD 460K / OSA 460RK	HIGH	2600	15	21	44.3	33.6	43.0	33.5	41.7	33.0	40.5	32.5	39.2	32.0	37.7	31.2
			17	23	46.5	34.2	45.6	33.5	44.3	33.0	43.0	32.5	41.7	32.0	40.5	31.4
			19	27	49.6	39.0	48.1	38.6	46.9	37.9	45.6	37.8	44.3	37.3	42.7	36.8
			21	31	52.4	44.3	50.9	43.7	49.6	43.2	48.4	42.9	46.9	42.4	45.3	41.9
ISD 461K / OSA 460RK	HIGH	2600	15	21	45.1	35.6	44.5	35.6	43.2	35.0	41.2	33.8	38.5	31.9	35.1	29.4
			17	23	47.5	34.8	46.9	34.8	45.6	34.2	43.5	33.1	40.9	31.5	37.5	29.2
			19	27	49.8	39.9	49.3	39.9	48.0	39.3	45.9	38.1	43.2	36.3	39.8	33.9
			21	31	52.2	47.2	51.6	47.3	50.3	46.7	48.3	45.3	45.6	43.3	42.2	40.6

Indoor Air Flow Correction Factors @ nominal conditions

Refer page 5 for pipe length capacity loss.

	Indoor Air Flow (%)			
	-20%	-10%	Rated	+10%
Total Capacity	0.95	0.975	1.0	1.025
Sensible Capacity	0.89	0.950	1.0	1.050

HEATING CAPACITY (kW)

G = Gross Heating Capacity kW, based on nominal air flow.
 N = Net Heating Capacity kW allowing for average defrost.
 ○ = Nominal Capacity (kW)

MODELS Indoor / Outdoor Unit	INDOOR ENTERING AIR TEMP. °C D.B.	OUTDOOR COIL ENTERING AIR TEMPERATURE (E.A.T.) °C D.B.															
		-5		-3		-1		1		3		5		7		9	
		G	N	G	N	G	N	G	N	G	N	G	N	G	N	G	N
ISD 330K / OSA 330RK	15	22.8	20.0	24.7	21.2	26.4	21.8	28.1	22.2	29.8	22.5	32.0	24.9	34.1	26.6	35.8	35.8
	20	22.4	19.6	24.2	20.8	25.9	21.4	27.6	21.8	29.2	22.1	31.4	22.9	33.4	26.1	35.1	35.1
	25	21.6	18.9	23.3	20.1	24.9	20.6	26.5	21.0	28.1	21.2	30.2	22.1	32.2	25.1	33.8	33.8
ISD 331K / OSA 330RK	15	21.8	19.1	23.6	20.3	25.2	20.8	26.8	21.2	28.4	21.5	30.5	23.7	32.5	25.4	34.1	34.1
	20	21.3	18.7	23.1	19.9	24.7	20.4	26.3	20.8	27.9	21.1	30.0	21.9	31.9	24.9	33.5	33.5
	25	20.6	18.0	22.2	19.1	23.8	19.6	25.3	20.0	26.8	20.3	28.8	21.1	30.7	23.9	32.2	32.2
ISD 406K / OSA 405RK	15	27.6	24.2	29.9	25.7	32.0	26.4	34.0	26.9	36.1	27.2	38.8	30.1	41.2	32.2	43.3	43.3
	20	27.1	23.7	29.3	25.2	31.3	25.9	33.4	26.4	35.4	26.7	38.0	27.7	40.4	31.5	42.5	42.5
	25	26.1	22.8	28.2	24.3	30.2	24.9	32.1	25.4	34.1	25.7	36.6	26.7	38.9	30.4	40.9	40.9
ISD 430K / OSA 430RK	15	28.1	24.6	30.4	26.2	32.5	26.8	34.6	27.4	36.7	27.7	39.5	30.7	42.0	32.8	44.1	44.1
	20	27.6	24.1	29.8	26.7	31.9	26.3	34.0	26.8	36.0	27.2	38.7	28.2	41.2	32.1	43.2	43.2
	25	26.6	23.2	28.7	24.7	30.7	25.3	32.7	25.8	34.7	26.2	37.3	27.2	39.6	30.9	41.6	41.6
ISD 460K / OSA 460RK	15	29.6	25.9	32.0	27.5	34.2	28.2	36.4	28.8	38.6	29.2	41.5	32.2	44.2	34.4	46.4	46.4
	20	29.0	25.4	31.4	27.0	33.6	27.7	35.7	28.2	37.9	28.6	40.7	29.7	43.3	33.8	45.5	45.5
	25	27.9	24.4	30.2	26.0	32.3	26.7	34.4	27.2	36.5	27.5	39.2	28.6	41.7	32.5	43.8	43.8
ISD 461K / OSA 460RK	15	30.1	26.4	32.6	28.1	34.9	28.8	37.1	29.3	39.4	29.7	42.2	32.8	45.0	35.1	47.2	47.2
	20	29.6	25.9	32.0	27.5	34.2	28.2	36.4	28.7	38.6	29.1	41.5	30.3	44.1	34.4	46.3	46.3
	25	28.5	24.9	30.8	26.5	32.9	27.2	35.0	27.7	37.2	28.1	39.9	29.1	42.5	33.1	44.6	44.6

PERFORMANCE DATA

AIR HANDLING

Note: Airflows are for a dry coil. Reduce airflow by 5% in high moisture removal conditions. In a free blow or low resistance application, beware of exceeding indoor fan motor's full load amp limit (refer back page). As filters are optional, the fan air flows given are for units installed without filters. If using EU-2 filter media, provide 0.08 m² face area per 100 l/s of airflow to maximise efficiency.

ISD 330K (Direct Drive)

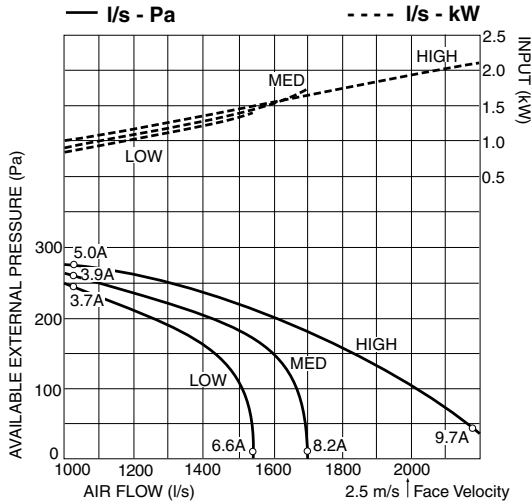

ISD 331K (Belt Drive)

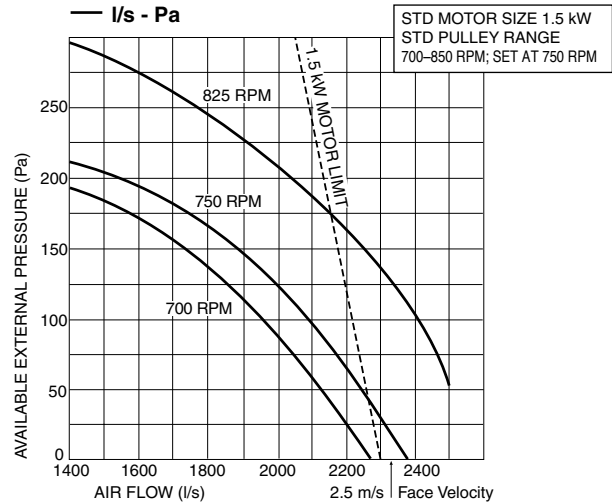

ISD 406K (Belt Drive)

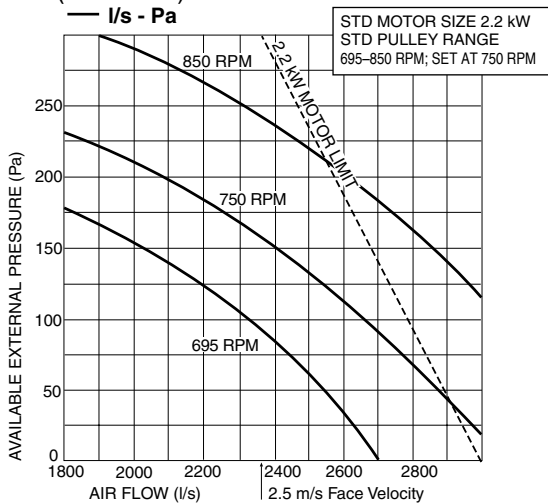

ISD 430K (Belt Drive)

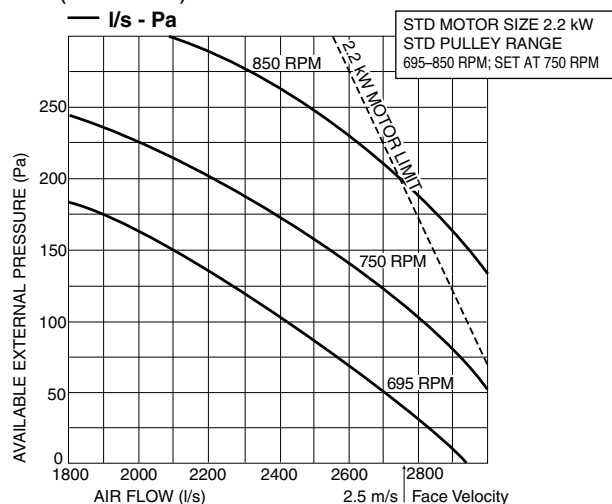

ISD 460K (Direct Drive)

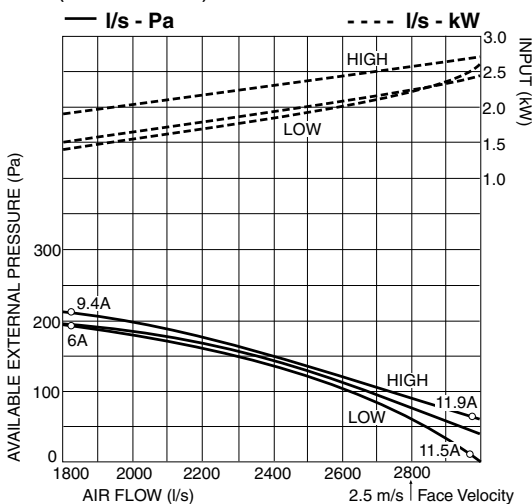

ISD 461K (Belt Drive)

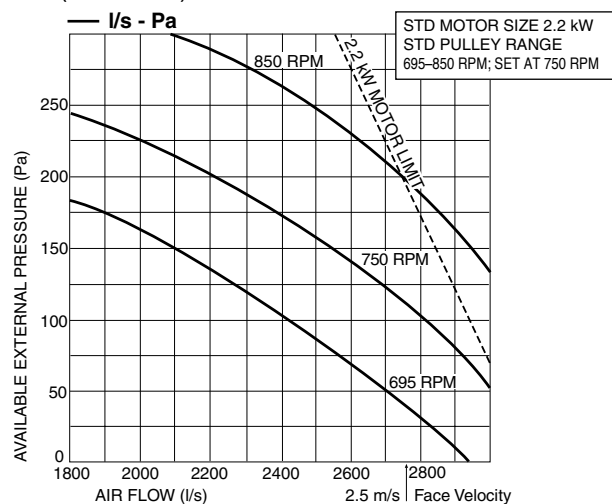

FILTER PRESSURE DROP

FILTER (clean)	Coil Face Velocity (m/s)	1.5	2.0	2.5
	Pressure Loss (Pa)	5	9	13

Optional ISD 330/460K filter box contains polypropylene net filter media. Refer back page for ISD 331/406/430/461K pleated filters pressure drop graph.

PERFORMANCE DATA

SOUND LEVELS

Sound Power Levels (SWL)

Test Conditions: BS 848 PT2 1985. Installation Type A (free inlet and outlet). Direct method of measurement (reverberant room). Measured in decibels re 1 picowatt.

Indoor Unit - Supply Air Outlet

MODEL	FAN SPEED	AIR FLOW l/s	SWL dB(A)	OCTAVE BAND FREQUENCY Hz					
				125	250	500	1 k	2 k	4 k
				SOUND POWER LEVELS (SWL) dB					
ISD 330K	LOW	1500	75	70	69	73	70	68	66
	MED	1650	76	71	71	74	71	69	67
	HIGH	1920	75	72	73	75	74	72	69
ISD 331K	690 RPM	1700	77	72	71	79	75	73	72
	825 RPM	1900	85	75	76	80	80	79	78
ISD 406K	750 RPM	2100	78	77	73	75	72	71	68
	810 RPM	2350	81	79	76	79	76	74	72
ISD 430K	750 RPM	2300	81	80	77	79	76	74	72
	810 RPM	2440	81	79	76	79	76	74	72
ISD 460K	LOW	2100	75	67	69	71	70	69	65
	MED	2100	75	67	69	72	70	69	66
	HIGH	2200	76	68	70	72	70	70	66
ISD 461K	750 RPM	2400	81	80	77	79	76	74	72
	810 RPM	2600	81	79	76	79	76	74	72

Outdoor Unit

Sound Pressure Level (SPL) in decibels re 20 µPa.

MODEL	FAN SPEED	SWL dB(A)	OCTAVE BAND FREQ. Hz						SPL @ 3 m dB(A)	OCTAVE BAND FREQ. Hz					
			125	250	500	1 k	2 k	4 k		125	250	500	1 k	2 k	4 k
			SOUND POWER LEVELS dB							SOUND PRESSURE LEVELS dB					
OSA 330	LOW	72	78	72	69	67	59	53	56	62	56	53	51	43	37
	HIGH	75	84	74	72	70	63	56	59	62	58	56	54	47	40
OSA 405	LOW	72	82	72	69	66	62	56	56	66	53	53	50	46	40
	HIGH	79	86	78	76	74	68	61	63	70	62	60	58	52	45
OSA 430	HIGH	79	82	80	77	75	69	61	63	66	64	61	59	53	45
OSA 460	LOW	79	87	82	79	68	66	58	63	71	66	63	52	50	42
	HIGH	79	85	81	78	70	68	62	63	69	65	62	54	52	46

PIPE LENGTH CAPACITY LOSS

ON COOLING CYCLE DUE TO PRESSURE DROP

Note: Loss percentage is approximate only.

No allowance made for vertical piping.

System	Pipe Size (mm)		Equivalent Line Pipe Length (m)				Additional Pipe Length to allow per Bend						
	Liquid	Suction	10	20	30	40	Suction Pipe Size OD			22 mm	28 mm	35 mm	
ISD / OSA 330	13	28	1.5 %	3.75 %	5 %	–	Long 90° Radius (2 x pipe dia.)	0.5 m	0.61 m	0.76 m			
ISD / OSA 405	16	35	1 %	2 %	3 %	4 %							
ISD / OSA 430	13	22	2.1 %	4.7 %	6.1 %	–							
ISD / OSA 460	16	35	1 %	2.5 %	4 %	6 %							

DIMENSIONS (mm)

Not to Scale

ISD 330K, 460K Indoor Unit (Direct Drive)

Note: ISD 330K has only two fans.

MODEL	A	B	C	D	E	F	G	H	J
ISD 330K	1540	715	975	300	320	1270	1392	678	195
ISD 460K	2000	745	1525	310	310	1710	1852	710	85

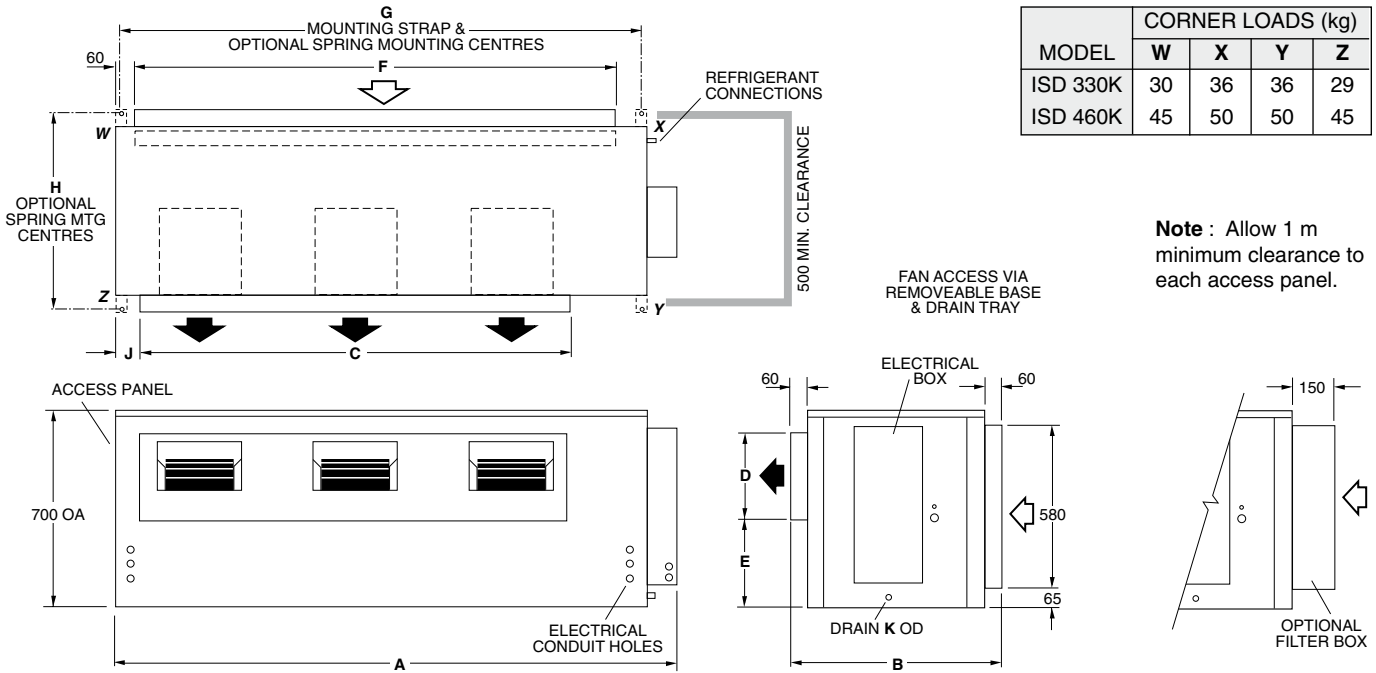

ISD 331K, 406K, 430K, 461K Indoor Unit (Belt Drive)

MODEL	A	B	C	D	E
ISD 331K	905	590	336	420	805
ISD 406K	905	445	477	420	805
ISD 430KB	1020	445	477	475	905
ISD 461K	1020	445	477	475	905

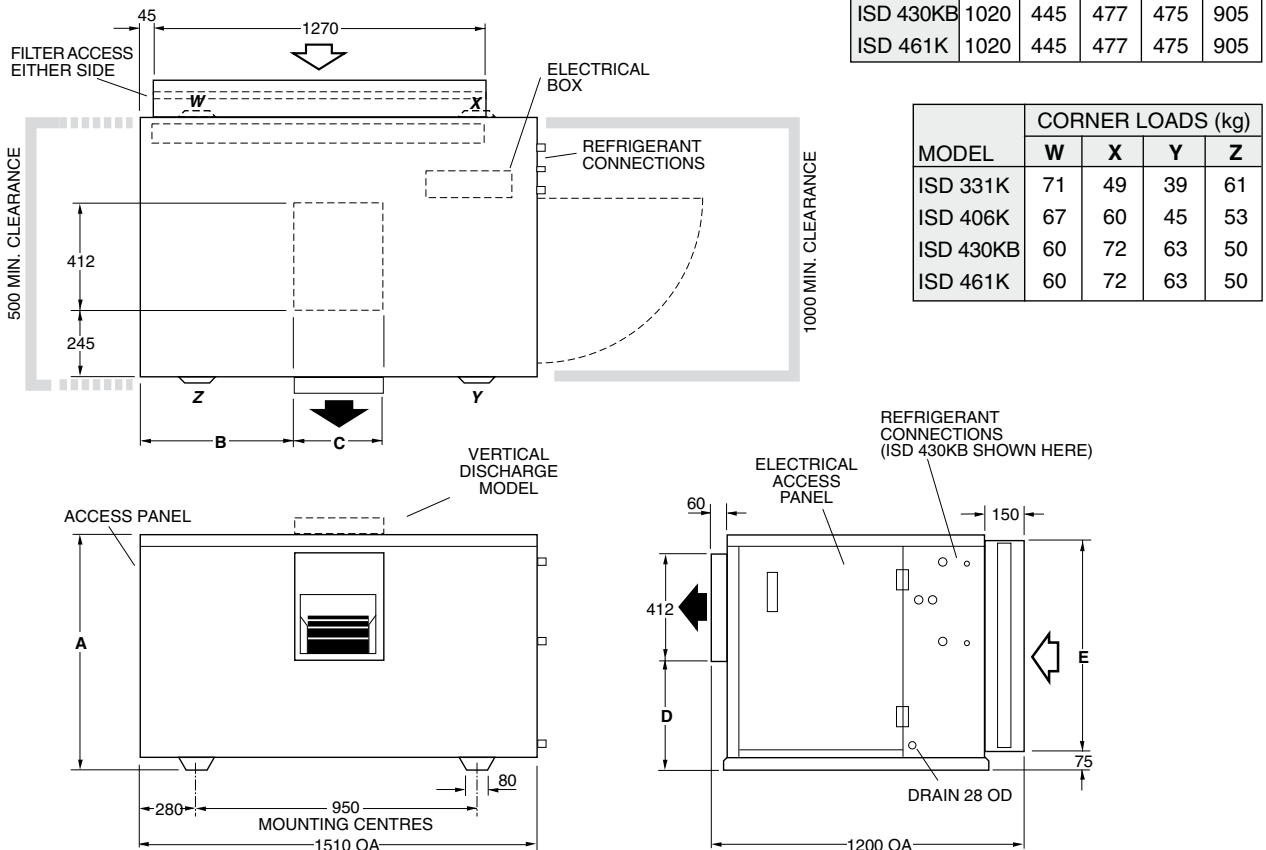

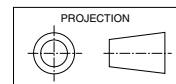

OSA 330, 405, 460 Outdoor Unit

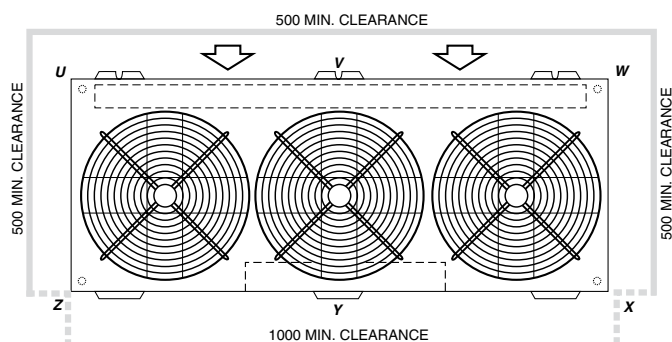

MODEL	K	L	M	N	P	Q
OSA 330	1680	825	1195	780	1353*	795
OSA 405	2010	765	1320	720	842	665
OSA 430	2235	825	1330	780	929	795
OSA 460	2235	825	1330	780	929	795

MODEL	CORNER LOADS (kg)					
	U	V	W	X	Y	Z
OSA 330	64	-	71	64	-	57
OSA 405	47	50	53	53	50	48
OSA 430	51	58	64	75	69	60
OSA 460	51	57	64	75	68	60

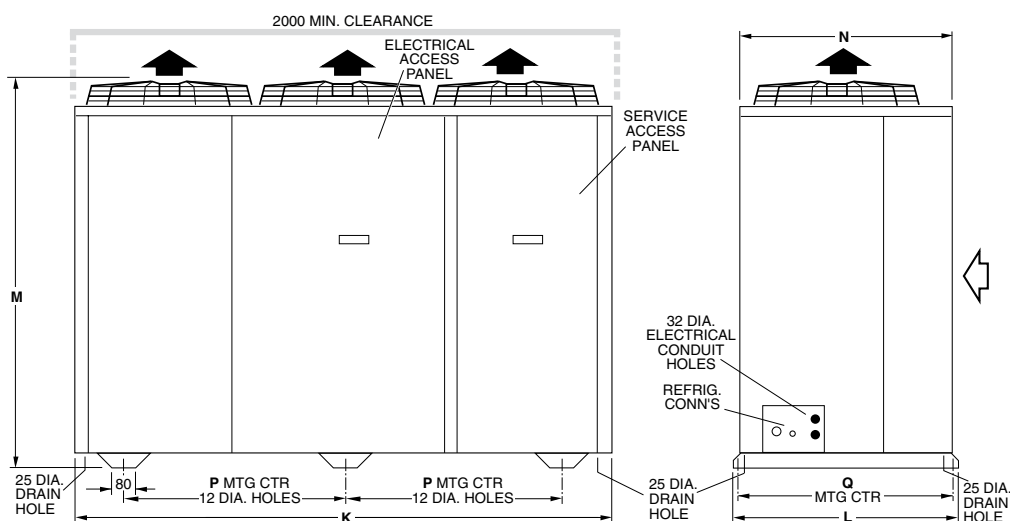

* OSA 330 has only two mounting rails and two upward discharge fans.

Refer back page for recommended pipe line sizes.

Note
Materials and specifications are subject to change without notice due to the manufacturer's ongoing research and development programme.

NOMENCLATURE

I S D

Series

I - Indoor
S - Split
D - Ducted

4 3 0 K B D H

Size

Divide by 10 to get approx. nominal Capacity in kilowatts

Type

K - R410A refrigerant compatible
B - Twin circuit system
D - TZT-701 Room Thermostat supplied
H - Horizontal discharge supply air fan
V - Vertical discharge supply air fan

O S A

Series

O - Outdoor
S - Split
A - Air Cooled

4 3 0 R K T B G V

Size

Divide by 10 to get approx. nominal Capacity in kilowatts

Type

R - Reverse cycle
K - Refrigerant R410A
T - Three phase power supply
B - Twin compressor system (twin circuit)
G - Digital scroll compressor (single)
V - Vertical discharge fans

SPECIFICATIONS

SYSTEM	Indoor Unit :	ISD 330K	ISD 331K	ISD 406K	ISD 430K	ISD 460K	ISD 461K
	Outdoor Unit :	OSA 330RK	OSA 330RK	OSA 405RK	OSA 430RKB*7	OSA 460RK	OSA 460RK
Cooling Capacity *1	kW	33.2	32.9	42.6	43.4	45.6	45.9
Heating Capacity *2 (OSA*R)	kW	33.4	31.9	40.4	41.2	43.3	44.1
E.E.R. (Cooling)		3.14	3.07	3.08	2.81	2.80	2.85
Air Flow *3	l/s	1800	1900	2350	2440	2600	2600
Sound Levels (SWL) *4:	- Indoor Unit	75	77	81	81	76	81
	- Outdoor Unit	75		79			
Power Source *5		3 phase 400 V a.c. 50 Hz					
Indoor Fan Type		1Ø direct drive	3Ø belt drive	3Ø belt drive	3Ø belt drive	1Ø direct drive	3Ø belt drive
Indoor Fan Full Load Amps	A	4.2 (x2)	3.3 /ph.	4.5 /ph.	4.7 /ph.	4.2 (x3)	4.7 /ph.
Running Amps (Total System)	A/ph.	17 / 18 / 18	17 / 17 / 20	19 / 19 / 24	31 / 27 / 26	24 / 22 / 22	26 / 27 / 30
Recommended External Protection	A/ph.	50		60		63	
Refrigerant		HFC - 410A (R410A)					
Standard Line Length	m	50					
Maximum Line Length *6	m	70					
Vertical Separation Limits (m):							
	- Outdoor unit above Indoor unit	20					
	- Outdoor unit below Indoor unit	20					
Recommended Interconnecting							
Pipe Sizes (mm OD):	- Suction	28		35	22 (x2)		35
	- Liquid	13		16	13 (x2)		16
Finish:	- Indoor Unit	zinc galvanised steel					
	- Outdoor Unit	grey polyester powder coat					
Weights (net/shipping) (kg):	- Indoor Unit	131 / 145	220 / 260	225 / 265	245 / 280	190 / 200	245 / 280
	- Outdoor Unit	256 / 298		301 / 355	377 / 436	331 / 390	

Notes:

- *1 Nominal Cooling Capacity at AS/NZS 3823 conditions:
Indoor Entering Air Temperature 27°C D.B., 19°C W.B.;
Outdoor Entering Air Temperature 35°C D.B.
- *2 Heating Capacity (reverse cycle units only)
at AS/NZS 3823 conditions:
Indoor Entering Air Temperature 21°C D.B.;
Outdoor Entering Air Temperature 7°C D.B., 6°C W.B.
- *3 Supply air flow at Nominal Cooling Capacity conditions stated above.
- *4 Sound Power Levels (SWL) are measured at nominal cooling capacity conditions stated above.
- *5 Voltage fluctuation limits 342-462 V.
- *6 Refer to manufacturer for additional piping requirements.
- *7 Twin compressor system. OSA 430RKTBG digital compressor model also available.

FILTER PRESSURE DROP

ISD 331K, 406K, 430K, 461K
Optional EU4 rated pleated filter.

Based on Koch Multi-Pleat HC filter.
Max. final pressure drop 250 Pa.

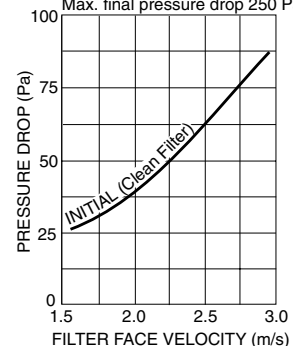

temperzone limited

Head Office, Auckland : 38 Tidal Rd, Mangere, N.Z.
Private Bag 93303, Otahuhu, NEW ZEALAND.
Email sales@temperzone.co.nz Website: www.temperzone.biz

temperzone australia Pty Ltd

Head Office, Sydney : 7A Bessemer St
PO Box 6448, Delivery Centre, Blacktown, NSW 2148,
AUSTRALIA. Email sales@temperzone.com.au

AUCKLAND

Ph. 0-9-279 5250
Fax 0-9-275 5637

WELLINGTON

Ph. 0-4-569 3262
Fax 0-4-566 6249

CHRISTCHURCH

Ph. 0-3-379 3216
Fax 0-3-379 5956

SYDNEY

Ph. (02) 8822-5700
Fax (02) 8822-5711

ADELAIDE

Ph. (08) 8376-1505
Fax (08) 8376-1449

SINGAPORE

Ph. SNG 6733 4292
Fax SNG 6235 7180

MELBOURNE

Ph. (03) 9551-7422
Fax (03) 9551-8550

BRISBANE

Ph. (07) 3399-2544
Fax (07) 3399-2577

NEWCASTLE

Ph. (02) 4962-1155
Fax (02) 4961-5101



PERTH

Ph. (08) 9314-3844
Fax (08) 9314-3855

TOWNSVILLE

Ph. (07) 4773-9566
Fax (07) 4773-9166

HOBART

Ph. (03) 6272-0066
Fax (03) 6272-0506

Available from