

ISD 405K, 460K

Ducted Split System Indoor Units

Installation & Maintenance

Fig.1 Dimensions (mm)

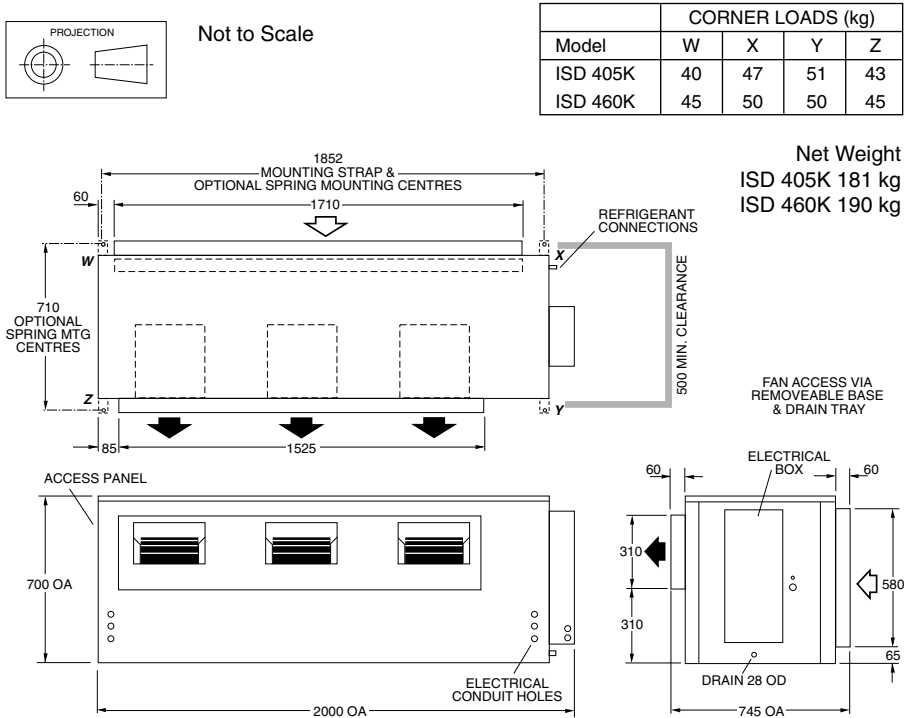

Note: The manufacturer reserves the right to change specifications at any time without notice or obligation. Certified dimensions available on request.

Fig. 2

Condensate Drain

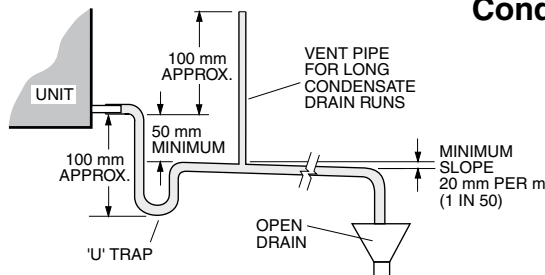

Fig. 3 Spring Mounting

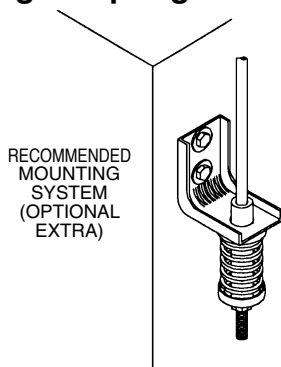
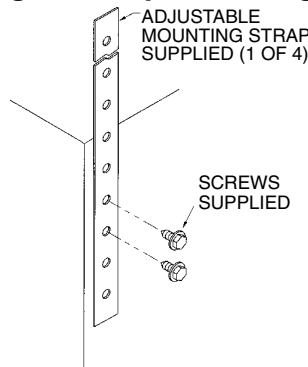

Fig. 4 Strap Mounting



GENERAL

These ISD indoor unit are designed to be coupled with their respective OSA outdoor unit:

- One ISD 405K with one OSA 405RKTV
- One ISD 460K with one OSA 460RKTV

Units must be installed in accordance with all national and local safety codes.

Options

- Filter Box c/w polypropylene net filter
- Spring Mounting Kit

AIR FILTRATION / FILTER BOX (Option)

As air filtration requirements vary, filters are not supplied with the unit. Filters should ideally be installed on the return air side of the unit, no closer than 500mm from the back of the unit and easily accessible for cleaning. To maximise the efficiency of air flow, the return air filter should be twice the area of the ISD unit's return air spigot/s. If efficiency is less of a concern a Filter Box is available.

The Filter Box is installed by unscrewing the return air spigot and replacing it with the filter box. The three filter panels may be accessed from either side of the box. The filter box adds 90 mm to the depth of the unit.

INSTALLATION

Positioning & Mounting

Provide 500 mm minimum clearance to the electrical panel. If the filter box option is to be used, allow adequate clearance for the two half length filters to be withdrawn from either side of the unit.

If low noise is a critical factor in the installation, refer to Figure 6 for noise isolation recommendations.

It is recommended that the unit be mounted using the spring mounting system, supplied as an optional extra (Fig.3). This system minimises transfer of vibration into the building structure.

If a more rigid installation can be tolerated, then suspend the unit using the four mounting straps supplied, as shown in Figure 4.

Alternatively, the unit can be mounted on a suitable platform using vibration isolators.

The unit has a built-in sloping drain tray, therefore mount it level.

Condensate Drain

The condensate drain should be trapped outside the unit cabinet. The trap should have a vertical height of at least 50 mm. The drain should have a slope of at least 1 in 50 and must not be piped to a level above the unit drain tray (refer Fig.2).

For long condensate pipe runs, fit a vent pipe near the drain trap. The top of the vent pipe must be at least 100 mm above the ISD unit's drain tray.

It is essential that the drainage system for the evaporator is checked by pouring water in the drain tray and seeing that it discharges at the end of the drain and does not overflow the drain tray.

Note: The built-in drain tray can be removed for cleaning (or fan access) by first removing the unit's base.

INDOOR-OUTDOOR UNIT CONNECTIONS

Refer to the relevant OSA Outdoor Unit 'Installation & Maintenance' pamphlet for piping instructions. For wiring connections, refer to the Outdoor Unit wiring diagram in conjunction with the ISD wiring diagram on this pamphlet.

REFRIGERATION PIPING

Pipe Connection Sizes & Type

ISD 405K :

Liquid : 16 mm OD ($\frac{5}{8}$ ") sweat
Suction : 35 mm OD ($1\frac{3}{8}$ ") sweat

ISD 460K :

Liquid : 16 mm OD ($\frac{5}{8}$ ") sweat
Suction : 35 mm OD ($1\frac{3}{8}$ ") sweat

The ISD is shipped from the factory with a pressurised holding charge of nitrogen. Immediately before removing any brazed pipe connection's seal, reduce holding charge to atmospheric pressure.

Warning: Failure to do so may cause injury.

Refer to the Outdoor Unit 'Installation & Maintenance' pamphlet for evacuation procedure and piping requirements.

ELECTRICAL WIRING

The electrical supply required (via the Outdoor Unit) is specified on the Outdoor Unit's wiring diagram.

Electrical work must be carried out by a qualified electrician in accordance with local supply authority regulations and the wiring diagram.

In a free blow or low resistance application, beware of exceeding the fan motor's full load amp limit (refer Outdoor Unit's wiring diagram).

To make the indoor fan switch off during de-ice cycle, refer to the Outdoor Unit wiring diagram for the appropriate changes.

INDOOR FAN SPEED

The fan speed can be set to LOW, MED, or HIGH - whichever best suits the application.

COMMISSIONING

Indoor Unit

1. Check that the thermostat is correctly wired and set at the desired temperature.
2. Check that any air filter (if fitted) is clean.
3. Check that the fan runs freely without vibration.
4. Check condensate drain for free drainage.

5. Run the unit in cooling and heating modes.

MAINTENANCE

Weekly For First Four Weeks

1. Check air filter (if fitted); vacuum clean as necessary.
2. Check condensate drain for free drainage.

Monthly

Check air filter (if fitted); vacuum clean as necessary.

Six Monthly

1. Check condensate drain for free drainage.
2. Check heat exchanger coil; vacuum or brush clean as necessary.
3. Check the tightness of the fan.
4. Check that fan motor is free running.
5. Check tightness of electrical connections.
6. Check air supply at diffuser outlets.

NOTE

The manufacturer reserves the right to change specifications at any time without notice or obligation. Certified dimensions available on request.

WARNING

This unit is designed for use ONLY with the refrigerant HFC-410A (R410A). The use of other refrigerants is NOT authorised or approved by the manufacturer and may cause operational problems such as poor performance and efficiency, loss of capacity, degradation of materials and refrigerant leaks.

The use of flammable or explosive materials as a refrigerant creates the additional risks of fire and explosion which may result in property damage, personal injury or death.

Fig. 5 Application Considerations

Recommendations for Noise Isolation

- particularly for high static installations:

1. Avoid installing units, with non-ducted return air, directly above spaces where noise is critical.
2. Use flexible connections between unit and rigid ducting.
3. Use generously sized acoustically lined ducts.
4. If generous duct size is not possible, use turning vanes on bends to reduce air turbulence (regenerated noise).
5. Use 90° bends in ducting to significantly assist in noise reduction.

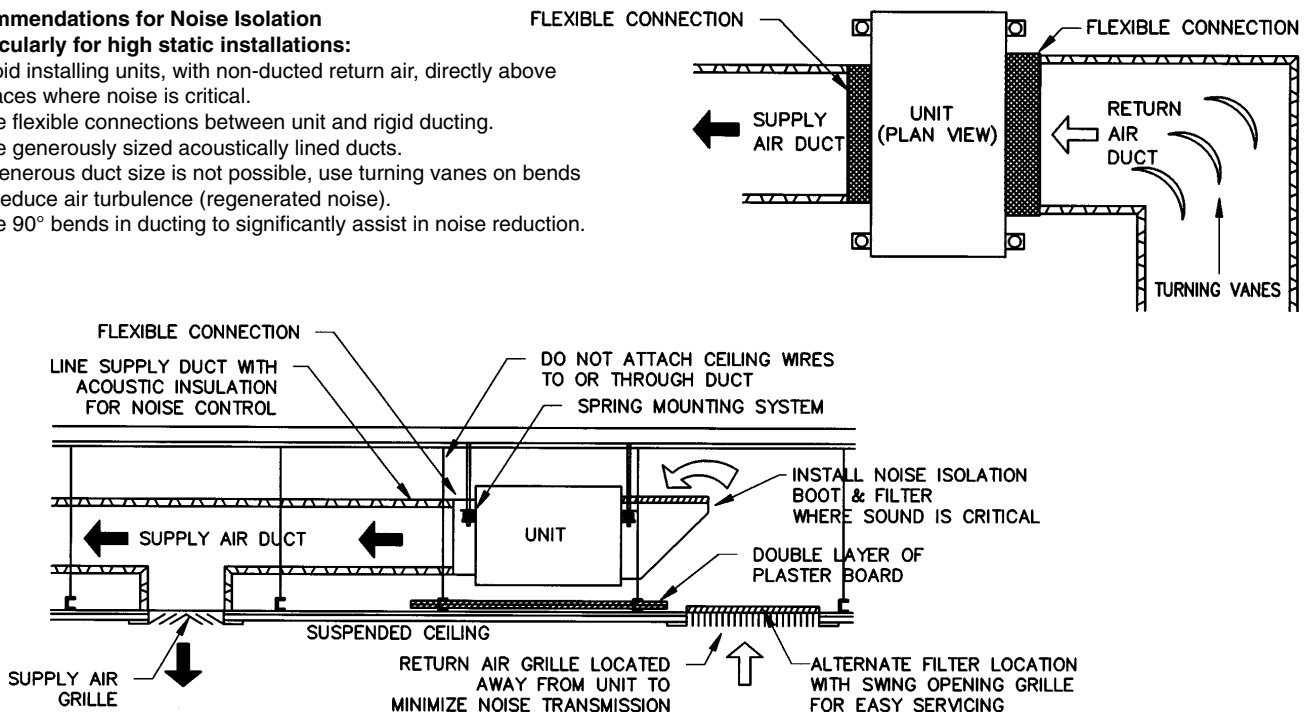

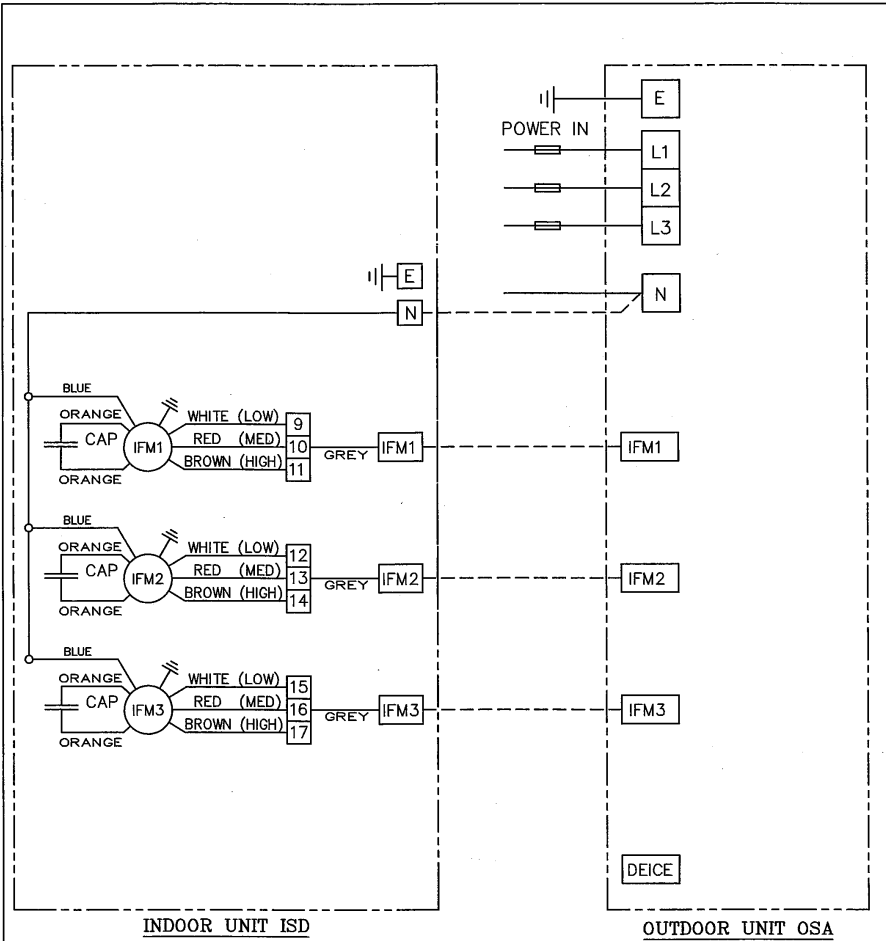

| | | | |
|------|------------------------------|-----|--------------------------|
| APS | AIR PRESSURE SWITCH | IFC | INDOOR FAN CONTACTOR. |
| EHC | ELECTRIC HEAT CONTACTOR | IFM | INDOOR FAN MOTOR |
| EHCC | ELECTRIC HEAT CONTACTOR COIL | LAT | LOW AMBIENT T/STAT |
| HR | HEATING RELAY | MST | MANUAL HIGH TEMP. T/STAT |
| HST | AUTO HIGH TEMP. T/STAT | CMC | COMPRESSOR CONTACTOR. |

| | | | | | | | |
|--|---------------|--|---------|--------------|------------------|-----------------------------------|----------|
| MODEL | ISD | 405K | 460K | | | ISD 405/460 K WIRING SCHEMATIC | |
| INDOOR FAN MOTOR | HIGH | 3.7 x 3 | 4 x 3 | | | | |
| RUNNING AMPS | MED | 3 x 3 | 3.5 x 3 | | | | |
| CAPACITOR | LOW | 2.8 x 3 | 3 x 3 | | | | |
| | MFD | 18 x3 | 18 x3 | | | temperzone | |
| | | | | | | ©temperzone Ltd 2001 | |
| NOTE: CHECK WIRING BEFORE SWITCHING ON, INCORRECT CONNECTION WILL DAMAGE MOTORS. | CLIENT WIRING | Interconnections between units by client. Double insulated multi-core cable. | | Drawn SDH | Date 14-12-07 | Drawing No. 525-534-002 | Revision |

