

# ISDL 55K – 110K

## Ducted Split System Indoor Units

## Installation & Maintenance

**Fig. 1 Dimensions (mm)**

MODEL	A	B	C	D	Net Weight	Spigots
ISDL 55K	950	840	872	930	28 kg	300 dia. (x4)
ISDL 56/80 K	1040	927	962	1020	30 kg	250 dia. (x6)
ISDL 95K	1235	1122	1157	1215	33 kg	250 dia. (x6)
ISDL 96/110 K	1430	1317	1352	1410	42 kg	250 dia. (x8)

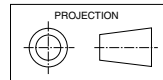

Not to Scale

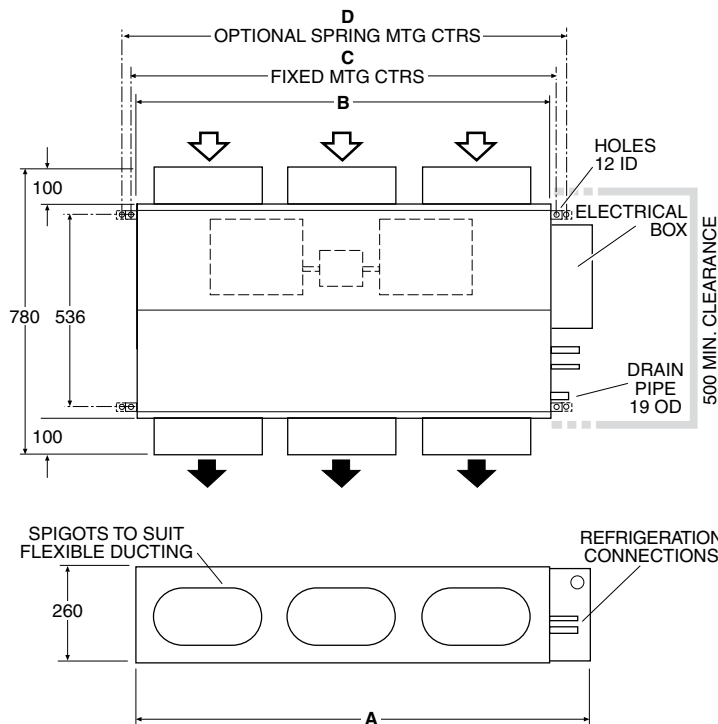

**NOTE**

The manufacturer reserves the right to change specifications at any time without notice or obligation. Certified dimensions available on request.

**GENERAL**

These ISDL\*K indoor units are designed to be coupled with the OSA\*RK outdoor units. Units must be installed in accordance with all national and local safety codes.

**Combinations**

- One ISDL 55K with one OSA 55RKS
- One ISDL 56K with one OSA 55RKS
- One ISDL 80K with one OSA 80RKS
- One ISDL 95K with one OSA 95RKS
- One ISDL 96K with one OSA 95RKS
- One ISDL 110K with one OSA 110RKS
- One ISDL 110K with one OSA 110RKT

**Options**

1. Filter Box
2. Spring Mounting Kit
3. Electric Heater Box

**AIR FILTRATION / FILTER BOX (Option)**

As air filtration requirements vary, filters are not supplied with the unit. Filters should ideally be installed on the return air side of the unit, no closer than 500 mm from the back of the unit and easily accessible for cleaning. To maximise the efficiency of air flow, the return air filter should be twice the area of the ISD unit's return air spigot/s. If efficiency is less of a concern a Filter Box is available.

The Filter Box fits between the ISDL's return air spigot plate and the main chassis. This addition adds 95 mm to the depth of the unit. The filter may be accessed from either side of the box.

**ELECTRIC HEATER BOX (Option)**

The Electric Heater Box fits between the ISDL's supply air spigot plate and the main chassis. This addition adds 190 mm to the depth of the unit. A separate page of installation instructions is supplied with the Kit.

**Fig. 2 Spring Mounting**

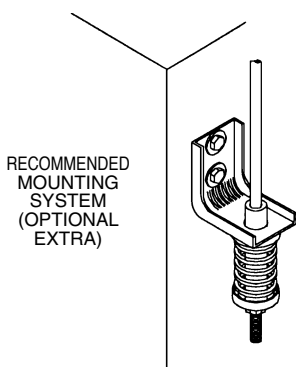

Fits in same position as brackets supplied with unit.

**Fig. 3 Solid Mounting**

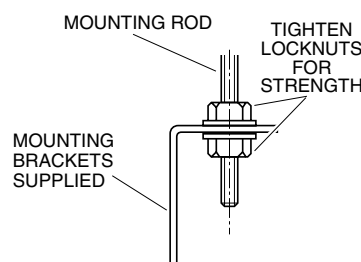

**INSTALLATION**

**Positioning & Mounting**

Provide 500 mm minimum clearance to the electrical box end of the unit. Allow adequate clearance for the filter to be withdrawn to its full length from either end of the unit. Alternatively the filter may be lifted out of its track.

If the Electric Heat Kit option is to be used, allow adequate clearance for servicing.

It is recommended that the unit be mounted using the spring mounting system, supplied as an optional extra (Fig.2). This system minimises transfer of vibration into the building structure.

If a more rigid installation can be tolerated, then suspend the unit from four threaded rods (not supplied) and use locknuts (not supplied), as shown in Figure 3. The 'L' shaped brackets, supplied on the unit's corners, must first be unscrewed and reversed to allow rod insertion.

Alternatively mount each unit on vibration isolators on a suitable platform.

The unit has a built in sloping drain tray so mount it level.

#### Condensate Drain

The drain should have a slope of at least 1 in 50 and must not be piped to a level above the unit drain tray. Fit a vent pipe within 500 mm of the unit. Check the drain by pouring water into the drain tray and ensuring that it clears.

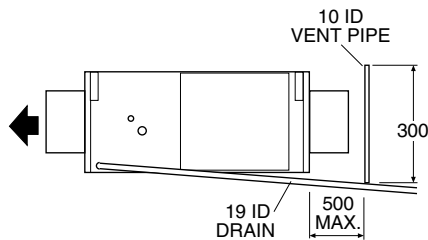

#### INDOOR-OUTDOOR UNIT CONNECTIONS

Refer to the relevant OSA Outdoor Unit 'Installation & Maintenance' pamphlet for piping instructions.

For wiring connections, refer to the Outdoor Unit wiring diagram in conjunction with the ISDL wiring diagram on this pamphlet.

#### REFRIGERATION PIPING

##### Pipe Connection Sizes (mm OD)

Model	Liquid	Suction
ISDL 55K	6 (1/4") sweat	13 (1/2") sweat
ISDL 56K	6 (1/4") sweat	13 (1/2") sweat
ISDL 80K	10 (3/8") sweat	16 (5/8") sweat
ISDL 95K	10 (3/8") sweat	16 (5/8") sweat
ISDL 96K	10 (3/8") sweat	16 (5/8") sweat
ISDL 110K	10 (3/8") sweat	19 (3/4") sweat

ISDL units are shipped from the factory with a pressurised holding charge of nitrogen. Immediately before removing any brazed pipe connection's seal, reduce the holding charge to atmospheric pressure.

**Warning:** Failure to do so may cause injury.

Refer to the Outdoor Unit 'Installation & Maintenance' pamphlet for evacuation procedure and piping requirements.

#### ELECTRICAL WIRING

The electrical supply required (via the Outdoor Unit) is specified on the Outdoor Unit's wiring diagram. Electrical work must be carried out by a qualified electrician in accordance with local supply authority regulations and the wiring diagram.

In a free blow or low resistance application, beware of exceeding the fan motor's full load amp limit (refer Outdoor Unit's wiring diagram).

It is recommended electricians run a spare wire between Outdoor Unit and Indoor Unit in case 'Indoor Fan Off During De-Ice' becomes a requirement. Leave this spare

wire unconnected until required. If and when this option is required, the loop wire must be removed between terminals 'N' and '1'.

#### ISDL/OSA Systems with Electric Heat

Replace the systems external fuse with the size recommended in the table on the Outdoor Unit's wiring diagram.

Note: Tandem indoor units with electric heat may require greater fuse sizes on the power supply.

#### INDOOR FAN SPEED

The fan speed can be set to LOW, MED, or HIGH - whichever best suits the application.

#### THERMOSTATS

A dedicated neutral line is required where electronic or anticipator thermostats are used when you choose to have indoor fan off in de-ice. Refer to **temperzone** for recommended thermostats.

#### COMMISSIONING

##### Indoor Unit

1. Check that the thermostat is correctly wired and set at the desired temperature.
2. Check that the air filter is clean.
3. Check that the fan runs freely without vibration.
4. Check condensate drain for free drainage.
5. Run the unit in cooling and heating modes.

##### Indoor Unit with Electric Heat

Test the air safety switch by running the fan on its lowest speed and checking for electrical heating. Remove power to the fans and the electric elements should cut-out. temperature (HST) overload and heater relay.

#### OPERATION

Units installed with electric heat kits includes both auto (90°C) and manual (120°C) high temp. safety thermostats. If the manual high temp. safety t/stat requires resetting and the auto high temp. safety t/stat does not reset, then the latter needs to be replaced.

#### MAINTENANCE

##### Weekly For First Four Weeks

1. Check air filter (if fitted); vacuum clean as necessary.
2. Check condensate drain for free drainage.

##### Monthly

Check air filter (if fitted); vacuum clean as necessary.

##### Six Monthly

1. Check condensate drain for free drainage.
2. Check heat exchanger coil; vacuum or brush clean as necessary.
3. Check the tightness of the fan.
4. Check that fan motor is free running.
5. Check tightness of electrical connections.
6. Check air supply at diffuser outlets.

#### WARNING

This unit is designed for use ONLY with the refrigerant HFC-410A (R410A). The use of other refrigerants is NOT authorised or approved by the manufacturer and may cause operational problems such as poor performance and efficiency, loss of capacity, degradation of materials and refrigerant leaks.

**The use of flammable or explosive materials as a refrigerant creates the additional risks of fire and explosion which may result in property damage, personal injury or death.**

#### Note

The manufacturer reserves the right to change specifications at any time without notice or obligation. Certified dimension available on request.

This pamphlet replaces the previous issue no. 3086 dated 05/09. ISDL 96K added.

**NOTE:**  
IT IS RECOMMENDED THE ELECTRICIAN RUN ONE SPARE WIRE BETWEEN OUTDOOR AND INDOOR UNITS. THIS IS ONLY REQUIRED IF THE INDOOR FAN IS TO BE FORCED OFF DURING DE-ICE CYCLE.  
THE WIRE SHOULD BE CONNECTED BETWEEN INDOOR TERMINAL 1 AND OUTDOOR TERMINAL (DE-ICE), AND THE WIRE BETWEEN 1 AND N ON THE INDOOR UNIT SHOULD BE DISCONNECTED.

**WARNING 1:** THE LOOSE PURPLE WIRE TIED TO CAPACITOR IS ONLY TO BE FITTED WHERE ONE FIXED SPEED IS USED. IT MUST NOT BE CONNECTED WHEN USING A MULTI SPEED SWITCH.

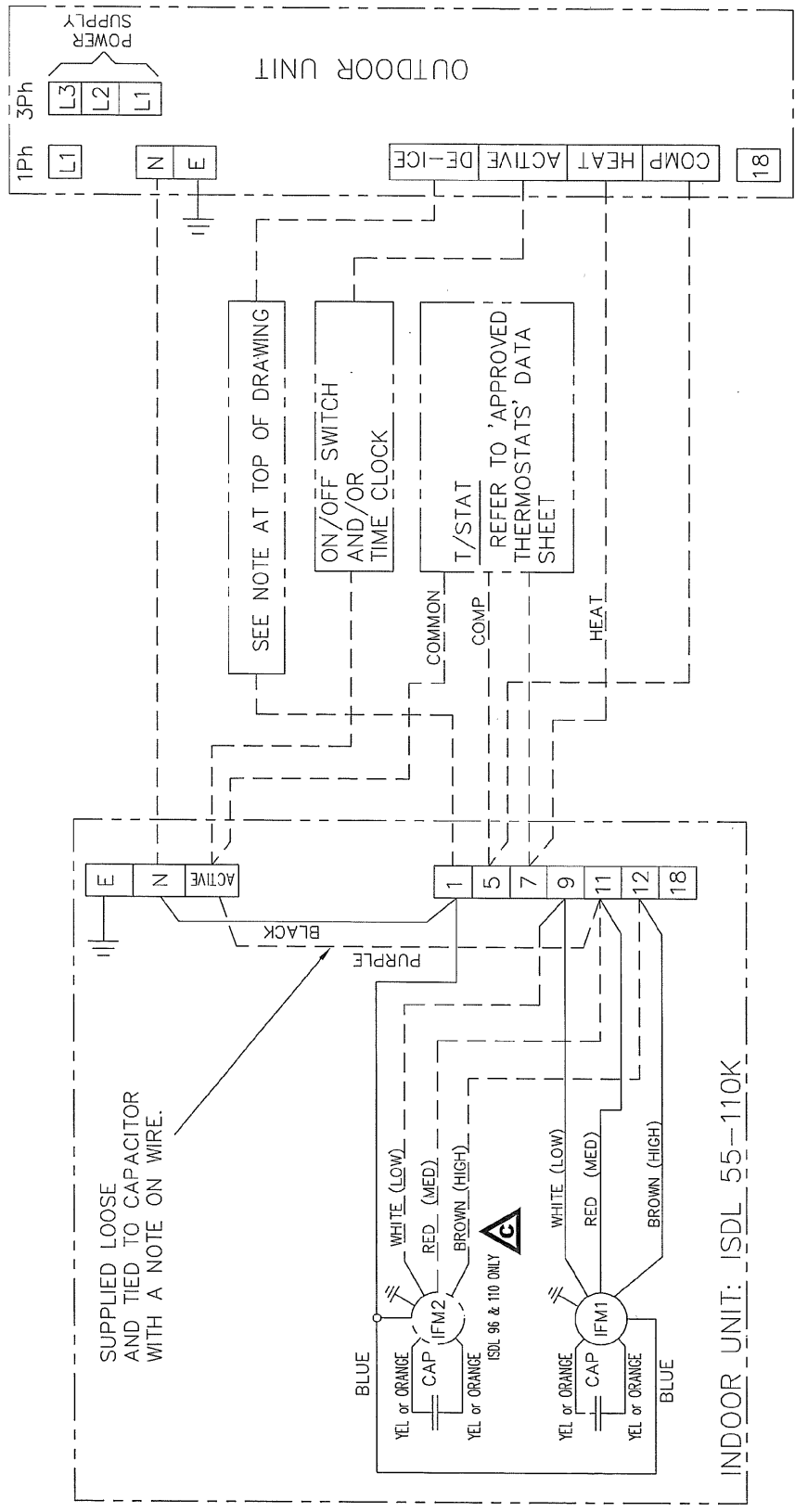

Title ISDL 55-110K (SLAVE)  
WIRING SCHEMATIC

Drawn B.P.	Date 17-05-06	Drawing No.	Revision
Scale	ASVD	525-094-002	C



MODEL	ISDL 55	ISDL 56	ISDL 80	ISDL 95	ISDL 96 & 110
INDOOR HIGH FAN MOTOR	0.87	0.94	0.94	1.03	1.3
FAN MED MOTOR	0.6	0.7	0.7	0.75	1.0
MOTOR LOW	0.51	0.58	0.58	0.65	0.88
CAPACITOR	5.0 MFD	5.0 MFD	5.0 MFD	5.0 MFD	3.5 MFD (75W MOTOR) 5.0 MFD (150W MOTOR)

**NOTE:** CHECK WIRING BEFORE SWITCHING ON. INCORRECT CONNECTION WILL DAMAGE MOTORS.

CAP	CAPACITOR
IFM1	INDOOR FAN MOTOR
IFM2	INDOOR FAN MOTOR (ISDL110 ONLY)
LAT	LOW AMBIENT T/STAT

ISSUE	MODIFICATION	ECN	DATE	APRVD
C	ISDL 96 DATA ADDED TO TABLE & NOTE	N240230-11-09	D.A.B	
B	ISDL 56 DATA ADDED TO TABLE	N219405-05-09	D.A.B	
A	CAPACITOR'S DATAS-ADDED	N153918-05-07	B.P.	

INDOOR UNIT: ISDL 55-110K

