

# OSA 390

## Split System Outdoor Unit

## Installation & Maintenance

### GENERAL

**OSA 390** - A general designation for outdoor unit  
**OSA 390C** - Outdoor unit, cooling only version  
**OSA 390R** - Outdoor unit, reverse cycle version

This OSA 390 Outdoor Unit must be installed in accordance with all national and local safety codes.

### INSTALLATION

#### Positioning

Refer to dimension diagram below for minimum clearances. Fasten the unit down to a firm flat horizontal base using the four holes provided in the mounting rails.

When the unit is being installed on a roof it is recommended that the unit is installed on a substantial structure with vibration isolating springs beneath the unit. These springs are not supplied with the unit.

### Drains

Four drain holes are provided in the base of the unit for the release of condensate and/or rain water. For a totally drip free installation mount the unit in a separate drain tray.

### Coil Protection

A coil protection guard is available as an optional extra.

### REFRIGERATION PIPING

#### General

The OSA 390 is shipped with a holding charge of refrigerant. The matched indoor unit is shipped with a holding charge of nitrogen. OSA 390 units have one flare and one brazed pipe connection.

### Recommended Pipe Sizes

Suction pipe : 35 mm OD  
 Liquid pipe : 16 mm OD

### Line Lengths

For line lengths in excess of 50 m, contact the manufacturer's nearest sales office for additional piping requirements. Refer also to *Oil Charge* overleaf.

Maximum extended line length is 70 m.

### Height Separation Limits

Outdoor Unit above Indoor Unit : 18 m  
 Outdoor Unit below Indoor Unit : 12 m

### Vertical Risers

If the outdoor unit is to be installed above the indoor unit, then the suction riser should be trapped at the bottom of the vertical riser and then again at 5 m (maximum) intervals. This is to ensure oil return to the compressor. The trap to be a 'swan neck' curve in the pipe, with no change in the pipe size.

## Dimensions (mm)

## OSA 390

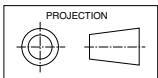

Not to Scale

### Net Weight

OSA 390C 279 kg  
 OSA 390R 287 kg

CORNER LOADS (kg)			
W	X	Y	Z
67	80	77	63

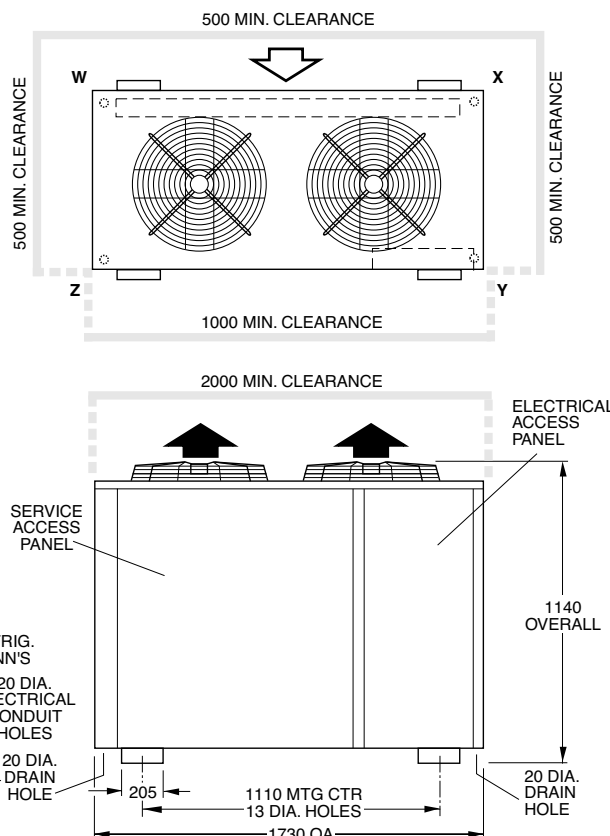

### Piping

1. Use clean sealed refrigeration grade piping.
  2. Cut pipe with a pipe cutter ONLY.
  3. Use long radius bends (2 x pipe dia.).
  4. Insulate the suction (gas) line and seal all insulation joints.
  5. Filter dryer may be fitted in the liquid line (bi-flow type on reverse cycle systems).
  6. Include a process point on the interconnecting pipework.
  7. Ensure open pipe ends are sealed until the final connection is made.
  8. Immediately before removing brazed pipe connection's seal, reduce holding charge between connection points and service valves to atmospheric pressure.
- Warning:** Failure to do so may cause injury.

### Charging

The unit is supplied with a 1 kg holding charge of refrigerant HCFC-22 (R22). Add 7.0 kg of HCFC-22 to complete the base charge, then add 105 g per metre of pipework between indoor and outdoor units.

#### Procedure:

1. Evacuate Indoor Unit and interconnecting pipework to a pressure of 500 microns and hold for 15 mins.
2. Add refrigerant via the Schraeder connection on the smaller of the Outdoor Unit's two service valves.
3. Open the service valve at the Outdoor Unit to allow refrigerant to flow throughout the system.
4. Leak check all brazed and fitted joints.

**IMPORTANT :**

Step 9 of the 'Start Up Procedure' requires you to check that the superheat on the suction line (where it enters the Outdoor Unit) is between 3°C - 5°C on cooling cycle with an indoor air temperature in the range 21° - 27°C and outdoor air temperature in the range 24° - 35°C. If the conditions of the day do not allow this, use the heating cycle (on a reverse cycle unit) or other heat source to raise the indoor air temperature to about 24°C and blank off the outdoor coil to raise the head pressure to 240–280 psig (1750–1950 kPag). Alter charge up or down to establish correct superheat.

**WARNING:**

This unit is designed for use ONLY with the refrigerant HCFC-22. The use of other refrigerants is NOT authorised or approved by the manufacturer and may cause operational problems such as poor performance and efficiency, loss of capacity, degradation of materials and refrigerant leaks. **The use of flammable or explosive materials as a refrigerant creates the additional risks of fire and explosion which may result in property damage, personal injury or death.**

**Oil Charge**

For line lengths in excess of 30 m, *Emcarate RL22CF* polyol ester oil (or similar) should be added to the refrigerant at the rate of 30 ml/m of suction piping. **Note:** Do not use mineral oil.

**ELECTRICAL REQUIREMENTS**

Electrical work must be done by a qualified electrician. The outdoor unit must be wired directly from a distribution board by means of a circuit breaker or H.R.C. fuse, and a mains isolator provided - preferably close to the Outdoor Unit.

**Note:** DO NOT USE REWIRABLE FUSES.

The OSA 390 is provided with a 24V AC control circuit for a thermostat, on/off switch and/or time clock.

The control transformer 240V primary voltage is used for countries with 230-240V power supply. For countries with supply voltages 200-220V, change the primary voltage on the transformer to 208V.

*OSA 390R only* - It is recommended electricians run a spare wire between Outdoor Unit and Indoor Unit in case boost electric heat becomes a requirement. **Note:** Leave the wire unconnected until required.

Standard units are suitable for use with thermostats with either manual Heat/Cool selection or automatic changeover subject to the contact ratings of the thermostats.

Refer to separate pamphlet for recommended thermostats, or contact the manufacturer's nearest sales office.

A 24 hour power supply to the crankcase heaters is required, otherwise the warranty is void.

**SYSTEM CHECK TESTS**

1. Leave the remote switch in the off position and close the mains isolating switch.  
A four hour delay period is required to allow the crankcase heater to drive any liquid refrigerant out of the compressor oil.
2. Check that all fan motors are free running.
3. Check that the thermostat is correctly wired to the unit and is set at the desired temperature.
4. Check that the air filters, if any, have been correctly installed.
5. Check any supply air diffuser dampers are open.

**START UP PROCEDURE**

Use the supplied Commissioning Sheet to help you complete the following procedure:

1. After the four hour delay period has expired switch on the unit.
2. Check the supply voltage.
3. Fit gauges and measure the suction and discharge pressures.
4. Check for correct rotation of the compressors. If rotation is incorrect a compressor will not pump, be noisy, and will draw minimal current. To correct motor rotation, change the phasing at the main power terminal.
5. Measure the current draw on each phase to the compressor motor and measure the current draw of each fan motor. Check all readings against the specified values - particularly the indoor fan amps if the unit is installed in a free blow application.
6. Test the operation of the high pressure safety control by switching off the outdoor unit's fan.
7. Test the operation of the reversing valve by running the unit in both the heating and cooling mode (OSA 390R only).
8. Check that the air flow over the outdoor unit's coil is adequate and that the fan is running smoothly.
9. Check the superheat - refer charging procedure.
10. Check the supply air flow at each outlet.
11. Touch up any outdoor unit paintwork damage to prevent corrosion.

This pamphlet replaces the previous issue no. 2549 dated 10/05. Oil Charge.

**OUTDOOR UNIT CONTROLLER (OUC) (OSA 390R only)**

The Outdoor Unit Controller (OUC) includes a temperature sensing head pressure control which enables the system to compensate for outdoor ambient temperatures below 20°C on cooling cycle, and above 15°C on heating cycle. The OUC also has features which protect against icing or overheating of coils, rapid cycling of the compressor and loss of refrigerant charge.

If the outdoor unit fans take some time to begin rotating when the system is powered on, or they don't appear to be rotating appropriately while the compressor is running, consult the OUC label on the electrical box. If necessary, refer to **temperzone** for further diagnostic information.

**MAINTENANCE**

**Weekly For First Four Weeks**

1. Check indoor unit air filters (if fitted) and vacuum or wash clean as necessary.
2. Check condensate drain for free drainage.
3. Check compressor compartment for oil stains indicating refrigerant leaks.
4. Check tightness of electrical connections.

**Three Monthly (or every 1200 hrs of operation)**

Check the indoor unit's fan belt tension and adjust if necessary.

**Six Monthly**

1. Check the tightness of all fan and motor mountings.
2. Check tightness of electrical connections.
3. Check that fan motors are free running.
4. Check suction and discharge operating pressures.
5. Replace indoor unit air filters (if fitted).
6. Check condensate drain for free drainage.

**Yearly**

1. Check all refrigerant piping for chafing and vibration.
2. Check the operation of electric heaters if fitted.
3. Check air supply at all diffusers.
4. Check for excessive noise and vibration and correct as necessary.
5. Check for insulation and duct damage and repair as necessary.
6. Remove lint and dust accumulation from outdoor coil fins.
7. Touch up any outdoor unit paintwork damage to prevent corrosion.

**NOTE**

The manufacturer reserves the right to change specifications at any time without notice or obligation. Certified dimensions available on request.

**Pipe Length Capacity Loss On Cooling Cycle Due to Pressure Drop**

**Note :** Loss percentages are approximations only, due to piping variations. No allowance made for vertical piping.

Pipe Size (mm)		Equivalent Line Pipe Length (m)				Additional Pipe Length to allow per Bend	
Liquid	Suction	10	20	30	40	Suction Pipe Size OD	35 mm
16	35	1 %	2 %	3 %	4 %	Long 90° Radius (i.e. 2 x pipe dia.)	0.76 m

OUTDOOR UNIT - OSA 390C  
WITH INDOOR UNIT  
CAPACITIES - NET to AS/NZS 3823  
COOLING - kW 36.6  
ELECTRICAL INPUT  
COOLING - kW 13.6  
E.E.R. (COOLING)  
kW/kW 2.691

ELECTRICAL  
SUPPLY REQUIRED 3Ph 342-436V ~ 50Hz  
INCLUDING VOLTAGE FLUCTUATION LIMITS  
COMPRESSOR (3PH) RUN AMPS RATED CONDITIONS A/Ph 16.5  
COMPRESSOR (3PH) STARTING AMPS A/Ph 24  
INDOOR FAN MOTOR (IPH) FULL LOAD AMPS A 6.3 x2  
INDOOR FAN MOTOR (IPH) FULL LOAD AMPS MFD 22.5  
OUTDOOR FAN MOTOR (IPH) FULL LOAD AMPS A 1.7 x2  
OUTDOOR MOTOR CAPACITOR MFD 8 x2  
RUNNING AMPS (TOTAL) A 21/23/21  
RECOMMENDED EXTERNAL FUSE SIZE A/Ph 50  
WEIGHT-NET OSA 390C 287 kg

REFRIGERANT - HCFC (R22)  
UNIT HOLDING CHARGE 1.0 kg  
BASE CHARGE UNIT 8 kg PLUS 105 grams PER METRE LINE LENGTH  
BASED ON LIQUID LINE #16 mm & GAS LINE #35 mm

CAP	CAPACITOR	HP	HI PRESSURE SWITCH
CB	CIRCUIT BREAKER	IFC	INDOOR FAN CONTACTOR
CCH	CRANK CASE HEATER	IFCC	INDOOR FAN CONTACTOR COIL
CM	COMPRESSOR MOTOR	IFM	INDOOR FAN MOTOR
CMC	COMPRESSOR CONTACTOR	LP	LOW PRESSURE SWITCH
CMCC	COMPRESSOR CONTACTOR COIL	OFM	OUTDOOR FAN MOTOR
CMOL	COMPRESSOR OVERLOAD	PRC	PHASE ROTATION CONTROL
CPP	COMPRESSOR PROTECTION PACK	PRR	PHASE ROTATION RELAY
CR	COOLING RELAY	PRRC	PHASE ROTATION RELAY COIL
CRC	COOLING RELAY COIL	TD	TIME DELAY 60 MIN DELAY ON BREAK
F	INDOOR FAN CONTROL	TK	CIRCUIT FOR OVERLOAD IN OUTDOOR FAN MOTOR
FR	INDOOR FAN CONTROL RELAY		
FRC	INDOOR FAN CONTROL RELAY COIL		

NOTE: CHECK WIRING BEFORE SWITCHING ON, INCORRECT CONNECTION WILL DAMAGE MOTORS.

Title OSA 390C  
WIRING SCHEMATIC



Drawn	P.W-M	Date	08-03-02	Drawing No.	327-634-008	Revision	A
Scale							

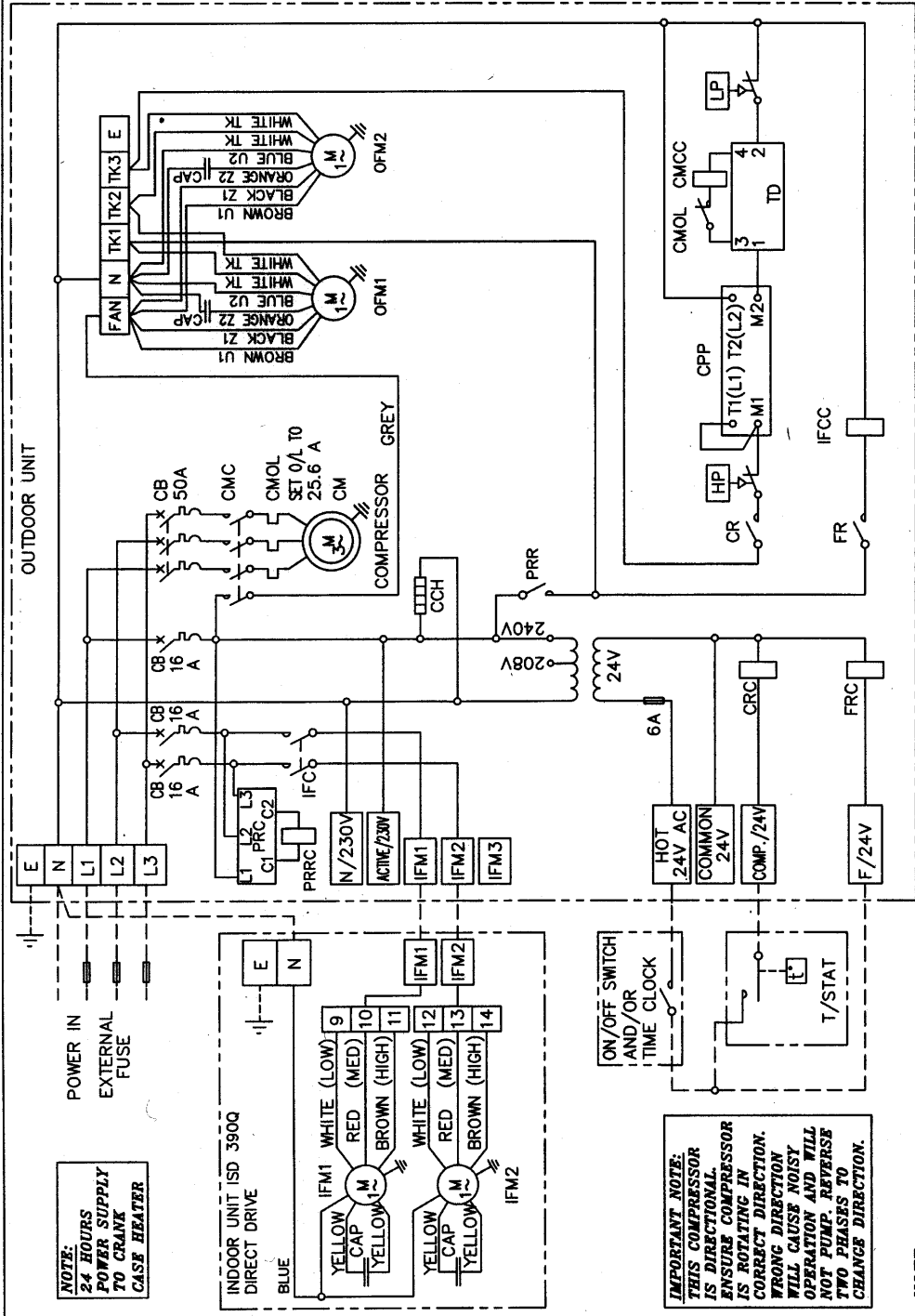

NOTE:  
A CONTROL TRANSFORMER 240V PRIMARY VOLTAGE IS USED FOR COUNTRIES WITH 230 - 240V POWER SUPPLY FOR COUNTRIES WITH SUPPLY VOLTAGE 200 - 220V, CHANGE PRIMARY VOLTAGE TO 208V ON TRANSFORMER.

CLIENT WIRING  
Interconnections between units by client. Double insulated multi-core cable.

ISSUE	MODIFICATION	ECN	DATE	APRVD	DRG SIZE	No.	DESCRIPTION	Mat.L	FINISH	ASSY No.
A	CHANGED TO NEW VOLTAGE AS PER AS/NZS 3823 STANDARDS. PHASE WIRE COLOURS REMOVED.	93012-05-03	D.A.B							

Programmed by

PLOTTED  
12-05-03  
©temperzone ltd  
2003

OUTDOOR UNIT: — OSA 390R	ISD 390Q
WITH INDOOR UNIT	
CAPACITIES — NET to AS/ANZS 3823	
COOLING — REVERSE CYCLE	kW 36.6
HEATING — REVERSE CYCLE	kW 36.9
ELECTRICAL INPUT	
COOLING —	kW 13.6
HEATING — REVERSE CYCLE	kW 12.1
E.E.R. (COOLING)	kW/kW 2.691
ELECTRICAL	
SUPPLY REQUIRED 3Ph 342-436V ~ 50Hz	
INCLUDING VOLTAGE FLUCTUATION LIMITS	
COMPRESSOR (3Ph) RUN AMPS RATED CONDITIONS	A/Ph 16.5
COMPRESSOR (3Ph) STARTING AMPS	A/Ph 24
INDOOR FAN MOTOR (1Ph) FULL LOAD AMPS	A 6.3 x2
INDOOR FAN MOTOR CAPACITOR	MFD 22.5 x2
OUTDOOR FAN MOTOR (1Ph) FULL LOAD AMPS	A 1.7 x2
OUTDOOR MOTOR CAPACITOR	MFD 8 x2
RUNNING AMPS (TOTAL)	A 21/23/21
RECOMMENDED EXTERNAL FUSE SIZE	A/Ph 50
ELECTRIC HEAT OPTION, ISD 390Q: 9kW TOTAL	A/Ph 13.1
RECOMMENDED EXTERNAL FUSE SIZE WITH ELECTRIC HEAT OPTION	A/Ph 60
WEIGHT—NETT OSA 390R	287 kg
REFRIGERANT — HOFC (R22)	
UNIT HOLDING CHARGE	1.0 kg
BASE CHARGE UNIT	8 kg PLUS 105 grams PER METRE LINE LENGTH
BASED ON LIQUID LINE Ø16 mm & GAS LINE Ø35 mm	

CAP	ICAPACITOR	HP	HI PRESSURE SWITCH
CB	CIRCUIT BREAKER	IFC	INDOOR FAN CONTACTOR
CCH	CRANK CASE HEATER	IFCC	INDOOR FAN CONTACTOR COIL
CM	COMPRESSOR MOTOR	IFM	INDOOR FAN MOTOR
CMC	COMPRESSOR CONTACTOR	LP	LOW PRESSURE SWITCH
CMCC	COMPRESSOR CONTACTOR COIL	OFM	OUTDOOR FAN MOTOR
CPP	COMPRESSOR PROTECTION PACK	PRC	PHASE ROTATION CONTROL
CR	COOLING RELAY	PRR	PHASE ROTATION RELAY
CRC	COOLING RELAY COIL	PRRC	PHASE ROTATION RELAY COIL
F	INDOOR FAN CONTROL		
FR	INDOOR FAN CONTROL RELAY		
FRC	INDOOR FAN CONTROL RELAY COIL		
HR	HEATING RELAY	TK	CIRCUIT FOR OVERLOAD IN OUTDOOR FAN MOTOR
HRC	HEATING RELAY COIL		

Consult Outdoor Unit Controller label for further details, or refer to Temperzone for fault diagnosis information.

Sensor Locations  
 Red to service valve pipe pocket.  
 Yellow to coil return bend pocket.  
 Blue to bottom of coil in fins.

Title	OSA 390R (OUC) WIRING SCHEMATIC		
Drawn	P.W-M	Date	29-11-04
Scale	1:1	Revision	A
		Drawing No.	426-634-002

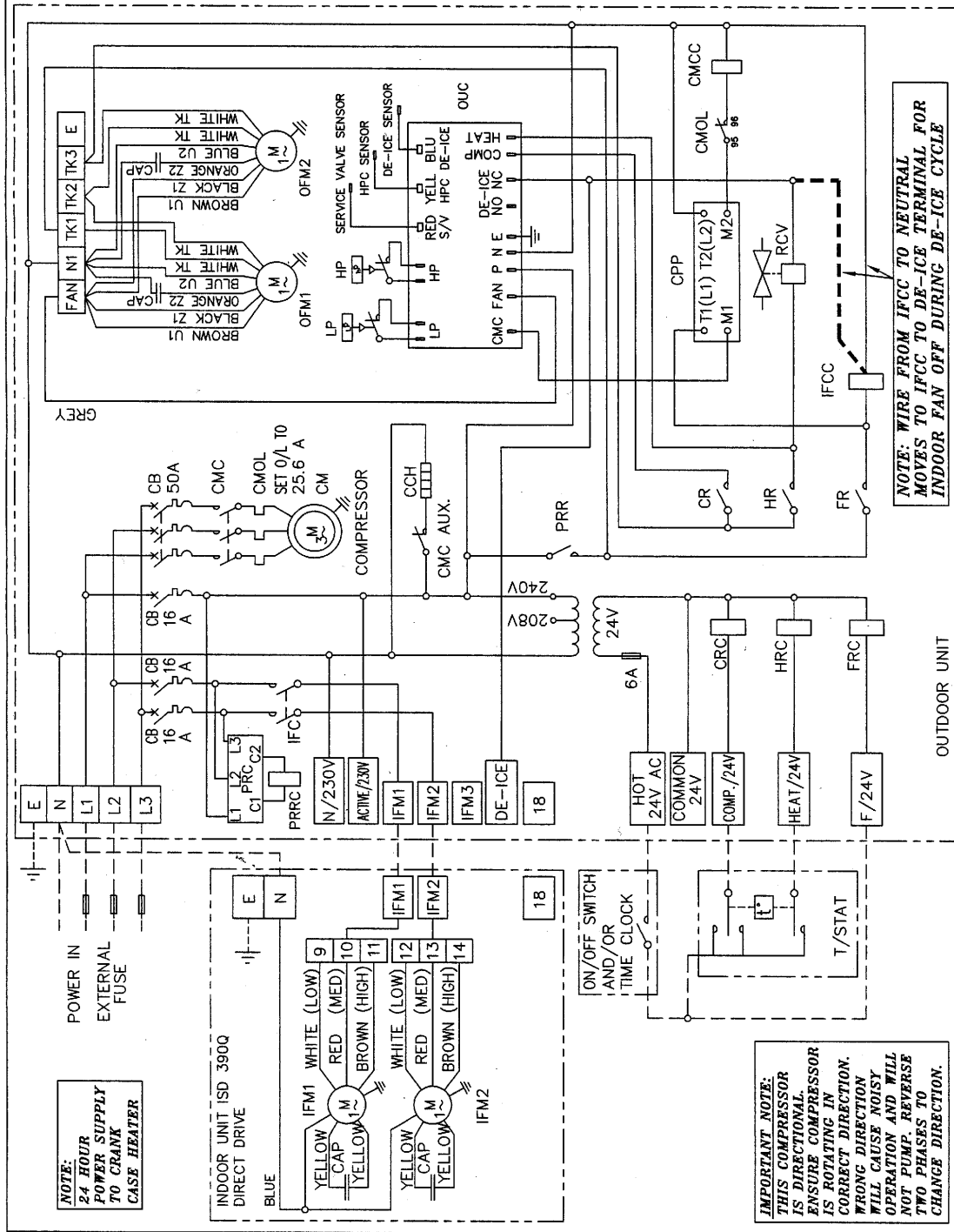
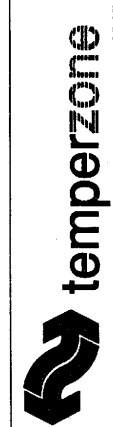

**NOTE:**  
 A CONTROL TRANSFORMER 240V PRIMARY VOLTAGE IS USED FOR COUNTRIES WITH 230 - 240V POWER SUPPLY FOR COUNTRIES WITH SUPPLY VOLTAGE 200 - 220V, CHANGE PRIMARY VOLTAGE TO 208V ON TRANSFORMER.

**NOTE:** CHECK WIRING BEFORE CLIENT WIRING. Interconnections between units by client. Double insulated multi-core cable.

**IMPORTANT NOTE:**  
 THIS COMPRESSOR IS DIRECTIONAL. ENSURE COMPRESSOR IS ROTATING IN CORRECT DIRECTION. WRONG DIRECTION WILL CAUSE NOISY OPERATION AND WILL NOT PUMP. REVERSE TWO PHASES TO CHANGE DIRECTION.

**NOTE:** WIRE FROM IFCC TO NEUTRAL MOVES TO IFCC TO DE-ICE TERMINAL FOR INDOOR FAN OFF DURING DE-ICE CYCLE

PLOTTED  
 20-10-05  
 ©temperzone ltd  
 2005