

**Ducted Three Phase
Packaged Air Conditioners**

Technical Data
OPA 225 – 405



R410A

Extra Long Life
Epoxy Coated Outdoor-Coil

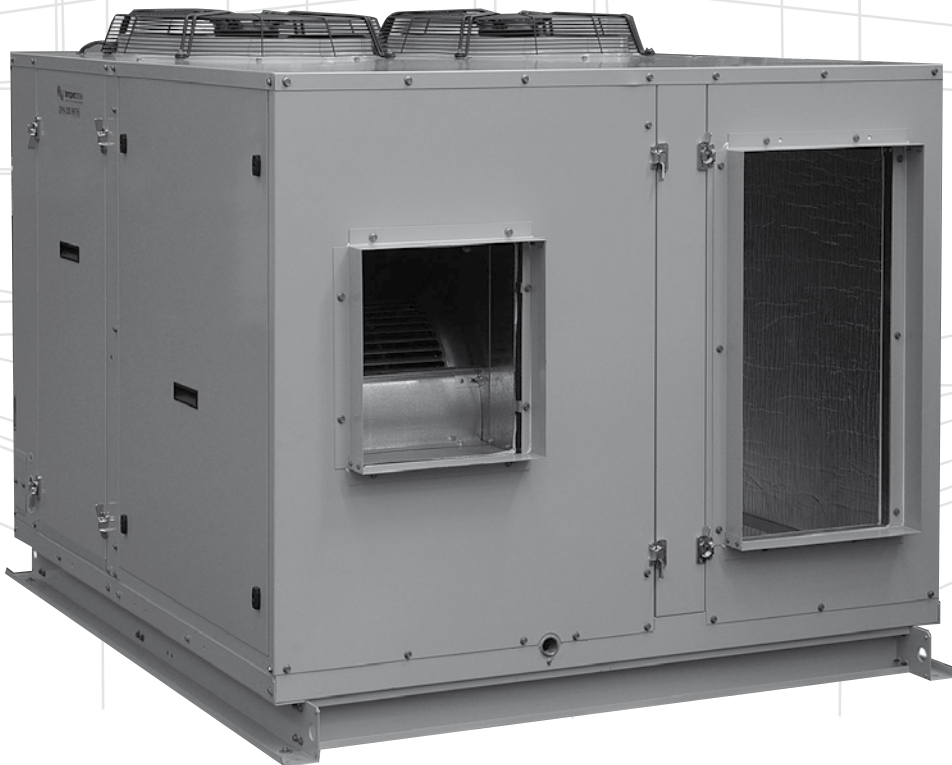

Nominal Cooling Capacity
23 kW – 41.4 kW

OPA 225, 270, 330, 405 – DUCTED PACKAGED ROOF TOP AIR CONDITIONERS

GENERAL

This OPA Series is a range of reverse cycle (heat pump) packaged roof top air conditioners designed and developed to comply with and exceed AS/NZS 3823 specified conditions (i.e. guaranteed cooling cycle performance at 43°C outdoor temperature).

APPLICATIONS

These units have been specifically developed for air conditioning of commercial premises, e.g. banks, supermarkets, shopping malls, food outlets, auditoriums and restaurants.

High humidity levels can occur in tropical or subtropical conditions, and/or when heavily moisture laden fresh air is introduced. Consideration must always be given to selecting an air flow and face velocity that avoids water carry-over problems.

Applications using full or high proportions of fresh air should be referred to your nearest **temperzone** sales office to establish the correct selection of units.

FEATURES

Refrigerant R410A. Each system uses refrigerant R410A which is deemed to have zero ozone depletion potential.

Economy. An economiser option is available to lower operating costs during the cooling cycle.

Efficient. Heat exchange coils incorporate inner grooved (rifled) tube for better heat transfer.

Performance. An adjustable pulley on the indoor air fan motor enables fine tuning to match the supply air requirements. Each system includes a temperature sensing head pressure control which enables the system to compensate for outdoor ambient temperatures below 20°C on cooling cycle, and above 15°C on heating cycle.

Quiet. The unit's generous insulation ensures a quiet unit.

Insulation. Foil faced closed cell foam insulation has been used in the indoor air section to ensure no particles are introduced into the air stream. The insulation is foil faced and meets fire test standards AS 1530.3 (1989) and BS 476 parts 6 & 7.

Durable. The cabinet and drain tray are constructed from high grade galvanised steel - polyester powder coated (colour Grey) for increased durability. External fasteners are stainless steel. Heat exchange coils comprise aluminium plate fins on mechanically expanded rifled copper tube. The outdoor coil fins are epoxy coated for extra protection in corrosive environments, e.g. salt laden sea air. Fan motor bearings are sealed for life so as not to incur regular maintenance.

Self Diagnostics. The OPA's Outdoor Unit Controller (OUC) has a display of LEDs to indicate faults and running conditions. A non-specific fault indicator is included for interface to external systems.

CONFIGURATIONS

Two versions are available for each model:

1. Horizontal supply/return air with box mounting channel (OPA*RKTH), or
2. Downward supply/return air with box mounting channel (OPA*RKTU).

OPTIONAL EQUIPMENT

1. **temperzone** TZT-701 thermostat.
2. Filters (rated EU4).
3. Economiser (factory fitted)
- includes dampers, weatherhood.
4. Adjustable fresh air damper and weatherhood.
5. Outdoor air coil protection guard.
6. Electronic control systems
- available by special arrangement.

SAFETY FEATURES

1. HP and loss of refrigerant protection.
2. Anti-rapid cycle timer and internal overload for compressor protection.
3. Circuit breaker control circuits.
4. Time-and-temperature controlled electronic de-ice prevents icing up of the outdoor coil during heating cycle.
5. Frost protection on cooling cycle.
6. Sensor fault indication.
7. Crankcase heater prevents liquid refrigerant condensing in the compressors during the 'off' cycle.
8. Compressor minimum run time to ensure oil return.
9. Phase rotation protection device.
10. 24V control circuit

COMPRESSOR/S

Each high efficiency scroll type compressor is hermetically sealed, quiet running and supported on rubber mounts to minimise vibration.

REFRIGERATION SYSTEM

The OPA units are factory charged with HFC-410A (R410A) refrigerant. Accurator expansion devices control the flow of refrigerant.

WIRING

The electrical supply required (including voltage fluctuation limits) is: 3 phase 342–436 V a.c. 50 Hz with neutral and earth. The compressor crankcase heater requires a 24 hour power supply. A control panel, with 24V control circuit, is located in the outdoor unit and is fully wired ready to accept the main power supply.

ECONOMISER OPTION

If the outdoor air heat content or temperature is below that of the return air, the fresh air damper opens and the return air damper closes to provide the first stage of cooling. The compressor(s) will then operate to provide more cooling if required. An alternative way of removing return air may be required when operating on 100% fresh air.

The manufacturer operates a quality management system that conforms to AS/NZS ISO 9001:2000.

*Also available:
OPA 430–960 models (43–96 kW)*

PERFORMANCE DATA

COOLING CAPACITY (kW)

Total = Total Capacity (kW)

Sens. = Sensible Capacity (kW)

E.A.T. = Entering Air Temperature

○ = Nominal Capacity (kW)

Note: Capacities are **gross** and do not include allowance for fan motor heat loss. For fan motor heat loss refer to Air Handling graphs.

MODEL	INDOOR FAN		INDOOR COIL E.A.T.		OUTDOOR COIL ENTERING AIR TEMPERATURE °C D.B.											
	SPEED	AIR I/s	W.B. °C	D.B. °C	23		27		31		35		39		43	
					Total	Sens.	Total	Sens.	Total	Sens.	Total	Sens.	Total	Sens.	Total	Sens.
OPA 225	HIGH	1260	15	21	22.1	16.8	21.4	16.7	20.8	16.4	20.2	16.2	19.5	15.9	18.8	15.5
			17	23	23.2	17.1	22.7	16.7	22.1	16.4	21.4	16.2	20.8	15.9	20.2	15.6
			19	27	24.7	19.4	24.0	19.2	23.3	18.9	22.7	18.8	22.1	18.6	21.3	18.3
			21	31	26.1	22.0	25.4	21.8	24.7	21.5	24.1	21.4	23.3	21.1	22.6	20.9
OPA 270	HIGH	1400	15	21	26.4	20.1	25.7	20.0	24.9	19.7	24.1	19.4	23.4	19.1	22.5	18.6
			17	23	27.7	20.4	27.2	20.0	26.4	19.7	25.7	19.4	24.9	19.1	24.1	18.7
			19	27	29.6	23.2	28.7	23.0	27.9	22.6	27.2	22.6	26.4	22.2	25.5	22.0
			21	31	31.3	26.4	30.4	26.0	29.6	25.8	28.8	25.6	27.9	25.3	27.0	25.0
OPA 330	HIGH	1800	15	21	32.1	24.4	31.2	24.2	30.2	23.9	29.3	23.5	28.4	23.1	27.3	22.6
			17	23	33.7	24.8	33.0	24.2	32.1	23.9	31.2	23.5	30.2	23.1	29.3	22.7
			19	27	35.9	28.2	34.8	27.9	33.9	27.4	33.0	27.4	32.1	27.0	31.0	26.7
			21	31	38.0	32.1	36.9	31.6	35.9	31.3	35.0	31.1	33.9	30.7	32.8	30.4
OPA 405	HIGH	2000	15	21	40.2	30.5	39.0	30.4	37.9	29.9	36.7	29.5	35.6	29.0	34.2	28.3
			17	23	42.2	31.1	41.4	30.4	40.2	29.9	39.0	29.5	37.9	29.0	36.7	28.5
			19	27	45.0	35.4	43.6	35.0	42.5	34.4	41.4	34.3	40.2	33.9	38.8	33.4
			21	31	47.6	40.2	46.2	39.7	45.0	39.2	43.9	39.0	42.5	38.5	41.1	38.0

Indoor Air Flow Correction Factors @ nominal conditions

	Indoor Air Flow (%)			
	-20%	-10%	Rated	+10%
Total Capacity	0.95	0.975	1.0	1.025
Sensible Capacity	0.89	0.950	1.0	1.050

HEATING CAPACITY (kW)

G = Gross Heating Capacity kW, based on nominal air flow.

N = Net Heating Capacity kW allowing for average defrost.

○ = Nominal Capacity (kW)

Reverse Cycle Systems

MODEL	INDOOR ENTERING AIR TEMP. °C D.B.	OUTDOOR COIL ENTERING AIR TEMPERATURE (E.A.T.) °C D.B.															
		-5		-3		-1		1		3		5		7		9	
		G	N	G	N	G	N	G	N	G	N	G	N	G	N	G	N
OPA 225	15	15.2	13.3	16.5	14.2	17.6	14.5	18.8	14.8	19.9	15.0	21.4	16.6	22.7	17.7	23.9	23.9
	20	14.9	13.1	16.2	13.9	17.3	14.3	18.4	14.5	19.5	14.7	21.0	15.3	22.3	17.4	23.4	23.4
	25	14.4	12.6	15.6	13.4	16.6	13.7	17.7	14.0	18.8	14.2	20.2	14.7	21.5	16.8	22.5	22.5
OPA 270	15	17.8	15.5	19.2	16.5	20.6	17.0	21.9	17.3	23.2	17.5	24.9	19.4	26.5	20.7	27.8	27.8
	20	17.4	15.2	18.9	16.2	20.2	16.6	21.5	16.9	22.8	17.2	24.4	17.8	26.0	20.3	27.3	27.3
	25	16.8	14.7	18.2	15.6	19.4	16.0	20.7	16.3	21.9	16.5	23.5	17.2	25.0	19.5	26.3	26.3
OPA 330	15	21.5	18.8	23.2	20.0	24.8	20.5	26.4	20.9	28.0	21.2	30.1	23.4	32.0	25.0	33.6	33.6
	20	21.0	18.4	22.8	19.6	24.3	20.1	25.9	20.5	27.5	20.7	29.5	21.5	31.4	24.5	33.0	33.0
	25	20.3	17.7	21.9	18.9	23.4	19.3	24.9	19.7	26.5	20.0	28.4	20.7	30.2	23.6	31.8	31.8
OPA 405	15	26.6	23.3	28.8	24.8	30.8	25.4	32.8	25.9	34.8	26.2	37.3	29.0	39.7	31.0	41.7	41.7
	20	26.1	22.8	28.2	24.3	30.2	24.9	32.1	25.4	34.1	25.7	36.6	26.7	39.0	30.4	40.9	40.9
	25	25.1	22.0	27.2	23.4	29.1	24/0	30.9	24.4	32.8	24.8	35.3	25.7	37.5	29.3	39.4	39.4

PERFORMANCE DATA

AIR HANDLING

Note: Airflows are for a dry coil. Reduce airflow by 5% in high moisture removal conditions. In a free blow or low resistance application, beware of exceeding indoor fan motor's full load amp limit (refer back page). As filters are optional, the fan air flows given are for units installed without filters.

OPA 225

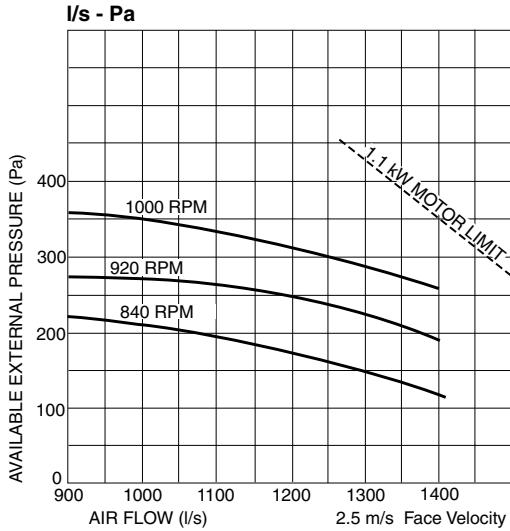

OPA 270

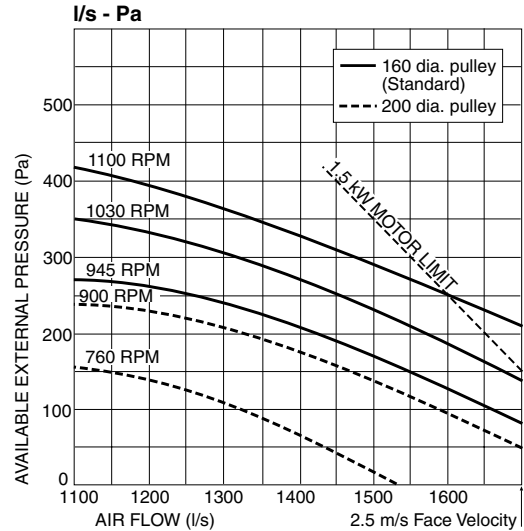

OPA 330

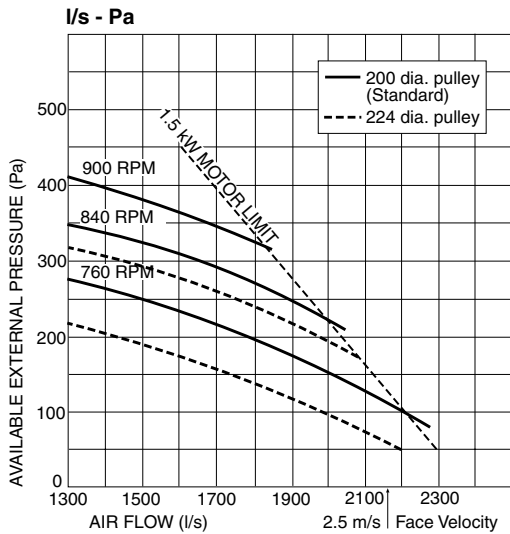

OPA 405

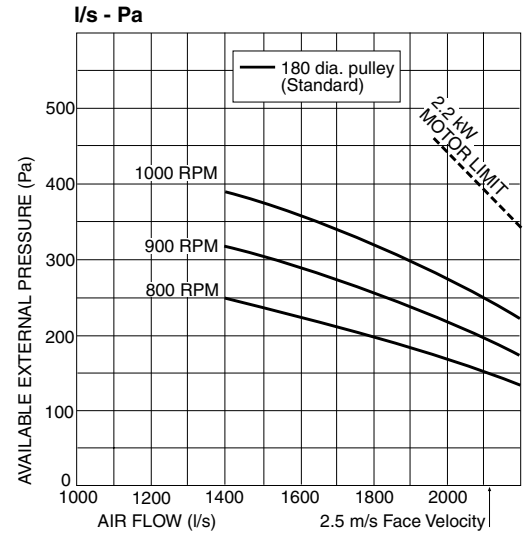

OPTIONAL FILTERS - PRESSURE DROP

Based on
Koch Multi-Pleat HC filter

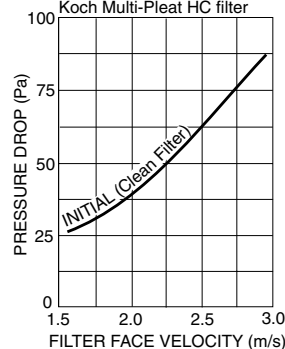

Model :		OPA 225	OPA 270	OPA 330	OPA 405
Std Motor Size	kW	1.1	1.5	1.5	2.2
Max. D.O.L. Motor	kW	2.2	2.2	3.0	3.0
Max. Fan Speed	RPM	1500	1500	1400	1400
Std Pulley Range	RPM	840-1000	945-1100	760-900	850-1000
Factory Setting	RPM	920	1025	830	925

PERFORMANCE DATA

SOUND LEVELS

RADIATED

Sound Power Levels (SWL)

Measured in decibels re 1 picowatt, at nominal airflow.

MODEL	OUTDOOR FAN SPEED	SWL dB(A)	OCTAVE BAND FREQUENCY Hz					
			125	250	500	1 k	2 k	4 k
			SOUND POWER LEVELS (SWL) dB					
OPA 225	LOW	72	79	70	68	68	61	60
	HIGH	73	80	73	68	68	62	60
OPA 270	HIGH	80	85	78	76	74	69	61
OPA 330	HIGH	78	84	78	76	74	70	63
OPA 405	LOW	81	85	74	77	77	74	70
	HIGH	83	87	76	74	81	74	69

Sound Pressure Levels (SPL)

Measured in decibels re 20 µPa, at nominal airflow.

MODEL	OUTDOOR FAN SPEED	SPL @ 3 m dB(A)	OCTAVE BAND FREQUENCY Hz					
			125	250	500	1 k	2 k	4 k
			SOUND PRESSURE LEVELS (SPL) dB					
OPA 225	LOW	56	63	54	52	52	45	44
	HIGH	57	64	57	52	52	46	44
OPA 270	HIGH	63	69	62	60	58	53	45
OPA 330	HIGH	62	68	62	60	58	54	47
OPA 405	LOW	65	69	58	61	61	58	54
	HIGH	66	71	60	58	65	58	53

Sound Power Levels (SWL)

Test Conditions: BS 848 PT2 1985. Installation Type A (free inlet and outlet). Direct method of measurement (reverberant room).
Measured in decibels re 1 picowatt.

SUPPLY AIR OUTLET

MODEL	INDOOR FAN SPEED	AIR FLOW l/s	SWL dB(A)	OCTAVE BAND FREQUENCY Hz					
				125	250	500	1 k	2 k	4 k
				SOUND POWER LEVELS (SWL) dB					
OPA 225	840 RPM	1260	81	77	74	79	77	73	71
OPA 270	945 RPM	1400	81	77	74	75	77	74	72
OPA 330	760 RPM	1800	87	82	81	83	83	80	77
OPA 405	935 RPM	2000	85	79	77	79	81	78	77

DIMENSIONS (mm)

Not to Scale

**Fig. 1 Horizontal Supply & Return Air
OPA*RKTH**

MODEL	A	B	C	D	E	F	G
OPA 225	1570	1490	1245	350	600	1500	290
OPA 270	1570	1490	1335	350	600	1500	290
OPA 330	1670	1490	1335	413	770	1605	210
OPA 405	1700	1490	1410	413	770	1635	245

Note: OPA 225 has low profile fans

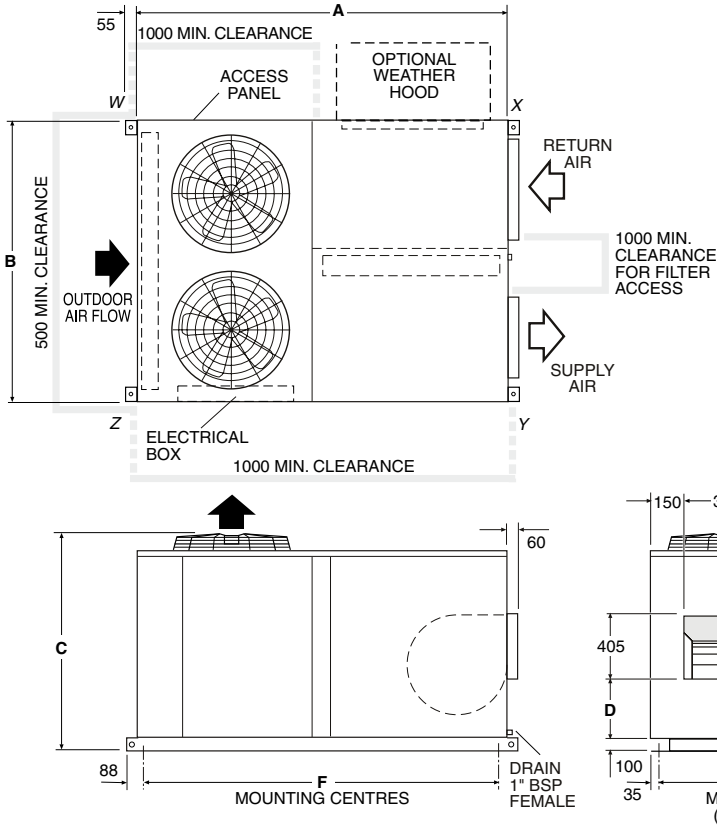

MODEL	POINT LOADS (kg)			
	W	X	Y	Z
OPA 225	95	92	104	108
OPA 270	106	93	100	113
OPA 330	116	98	115	133
OPA 405	128	116	130	142

**Fig. 2 Downward Supply & Return Air
OPA*RKTU**

MODEL	H	J	K	L	M
OPA 225	575	150	310	340	185
OPA 270	575	150	310	340	180
OPA 330	745	210	330	400	170
OPA 405	745	210	330	400	170

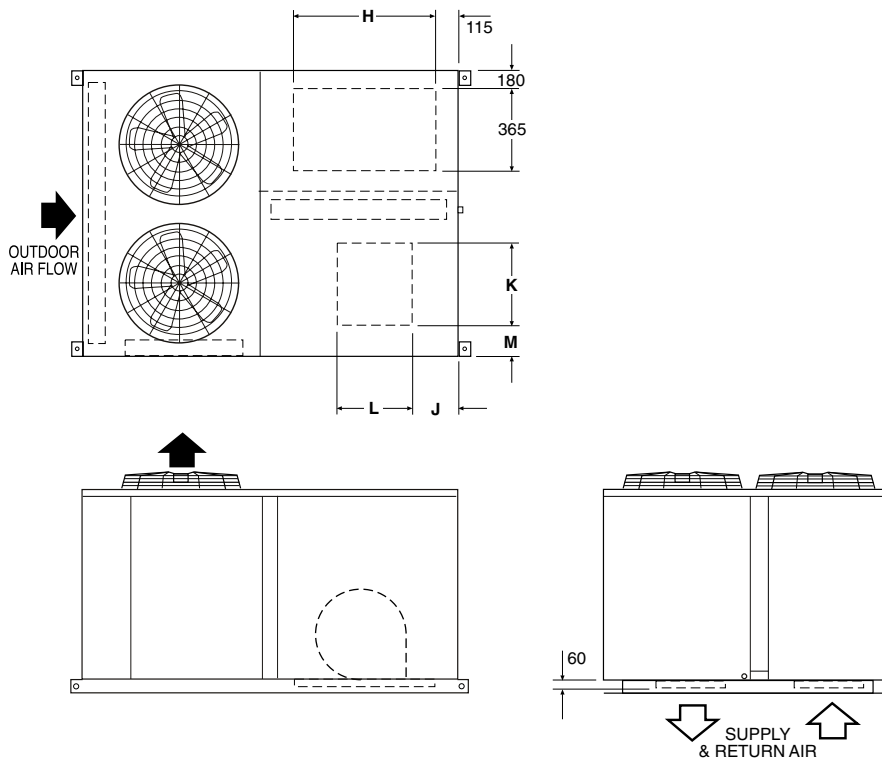

Note:
Refer to Fig.1 for overall dimensions and clearances.

NOTE
The manufacturer reserves the right to make changes in specifications at any time without notice or obligation. Certified data is available on request.

Fig. 5 Economiser Option

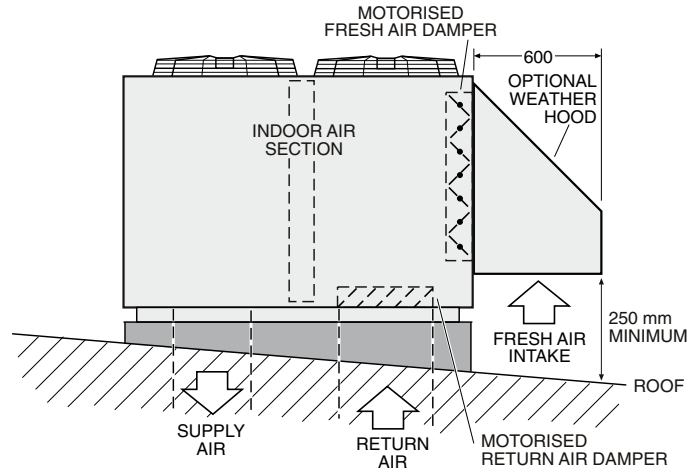
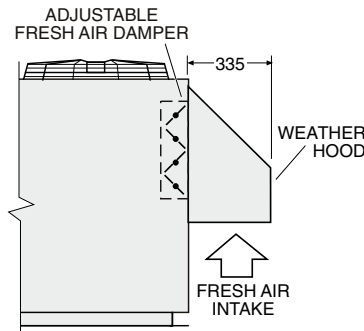

Fig. 6 Fresh Air Damper Option



Nomenclature

e.g.	O P A	2 7 0	R K T H	- C Z
	<i>Series</i>	<i>Size</i>	<i>Type</i>	<i>Options</i>
	O - Outdoor P - Packaged A - Air Cooled	Divide by 10 to get approx. nominal Capacity in kilowatts	R - Reverse cycle K - Refrigerant R410A T - Three phase power supply B - Twin compressor system (twin circuit) H - Horizontal discharge supply air fan U - Downward discharge supply air fan	C - Fresh Air Z - Economiser

SPECIFICATIONS

Model		OPA 225	OPA 270	OPA 330	OPA 405
Cooling Capacity *1	kW	22.7	27.2	33.0	41.4
Heating Capacity *2	kW	22.3	26.0	31.4	39.0
E.E.R. (Cooling)		3.16	3.06	3.19	2.82
Air Flow *3	l/s	1260	1400	1800	2000
Power Source *4		3 phase 342-436 V a.c. 50 Hz			
Indoor Fan Full Load Amps	A/ph.	2.6	3.3	3.3	4.6
Running Amps (Total System)	A/ph.	14 / 14 / 15	20 / 15 / 16	16 / 18 / 18	29 / 26 / 25
Recommended External Fuse	A/ph.	25	40	40	50
Finish		Grey polyester powder coat			
Net Weight	kg	398	411	462	518
Shipping Weight (approx.)	kg	454	467	525	571

Notes:

*1 Nominal Cooling Capacity at AS/NZS 3823 conditions: Indoor Entering Air Temperature 27°C D.B., 19°C W.B.;
Outdoor Entering Air Temperature 35°C D.B.

Subtract indoor fan power to calculate Net Capacity.

*2 Heating Capacity (reverse cycle units only) at AS/NZS 3823 conditions: Indoor Entering Air Temperature 21°C D.B.;
Outdoor Entering Air Temperature 7°C D.B., 6°C W.B.

*3 Supply air flow at Nominal Cooling Capacity conditions stated above.

*4 Power source includes voltage limits.



temperzone limited

Head Office, Auckland : 38 Tidal Rd, Mangere, N.Z.
Private Bag 93303, Otahuhu, NEW ZEALAND.
Email sales@temperzone.co.nz Website: www.temperzone.biz

temperzone australia Pty Ltd

Head Office, Sydney : 7A Bessemer St
PO Box 6448, Delivery Centre, Blacktown, NSW 2148,
AUSTRALIA. Email sales@temperzone.com.au

AUCKLAND

Ph. 0-9-279 5250
Fax 0-9-275 5637

WELLINGTON

Ph. 0-4-569 3262
Fax 0-4-566 6249

CHRISTCHURCH

Ph. 0-3-379 3216
Fax 0-3-379 5956

SYDNEY

Ph. (02) 8822-5700
Fax (02) 8822-5711

ADELAIDE

Ph. (08) 8376-1505
Fax (08) 8376-1449

SINGAPORE

Ph. SNG 6733 4292
Fax SNG 6235 7180

MELBOURNE

Ph. (03) 9551-7422
Fax (03) 9551-8550

BRISBANE

Ph. (07) 3399-2544
Fax (07) 3399-2577

NEWCASTLE

Ph. (02) 4962-1155
Fax (02) 4961-5101



PERTH

Ph. (08) 9314-3844
Fax (08) 9314-3855

TOWNSVILLE

Ph. (07) 4773-9566
Fax (07) 4773-9166

HOBART

Ph. (03) 6272-0066
Fax (03) 6272-0506

Available from