

**Ducted Three Phase
Packaged Air Conditioner**

Technical Data

OPA 100, 135, 155, 178



Extra Long Life
Epoxy Coated Outdoor Coil



**Nominal Cooling Capacity
10.6 kW – 18.2 kW**

OPA 100, 135, 155, 178 – DUCTED PACKAGED ROOF TOP AIR CONDITIONERS

GENERAL

This OPA Series is a range of reverse cycle (heat pump) packaged roof top air conditioners designed and developed to comply with and exceed AS/NZS 3823 specified conditions (i.e. guaranteed cooling cycle performance at 43°C outdoor temperature).

Nomenclature

OPA 100 R K T

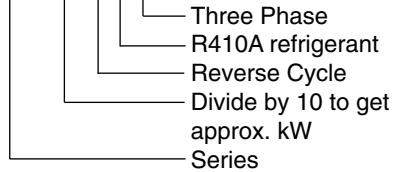

APPLICATIONS

These units have been specifically developed for air conditioning of commercial premises, e.g. banks, offices, motels, shops, food outlets and restaurants.

Air Flow Selection

If the air returning to the indoor coil is regularly expected to be above 50%RH, then the coil face velocity should be limited to be 2.5 m/s or less (refer Air Flow graph; 2.5 m/s is clearly marked).

High humidity levels can occur in tropical or subtropical conditions, and/or when heavily moisture laden fresh air is introduced. Consideration must always be given to selecting an air flow and face velocity that avoids water carry-over problems.

Applications using full or high proportions of fresh air should be referred to your nearest **temperzone** sales office to establish the correct selection of units.

FEATURES

Refrigerant R410A. Each complete system uses refrigerant R410A which is deemed to have zero ozone depletion potential.

Efficient. Each unit incorporates a high efficiency scroll compressor. Heat exchange coils incorporate inner grooved (rifled) tube for better heat transfer.

Performance. A dynamically balanced forward curved fan with a multi-speed motor enables fine tuning of the indoor unit to match the supply air requirements. Each system includes a temperature sensing head pressure control which enables the system to compensate for outdoor ambient temperatures below 20°C on cooling cycle, and above 15°C on heating cycle.

Quiet. The compressor is isolated in a built-in compartment to minimise noise. Generous use of insulation also ensures a quiet unit.

Insulation. Closed cell foam insulation has been used in the indoor air section to ensure no particles are introduced into the air stream. The insulation is foil faced and meets fire test standards AS 1530.3 (1989) and BS 476 parts 6 & 7.

Durable. The cabinet is constructed from high grade galvanised steel - polyester powder coated (colour Grey) for all weather protection. External fasteners are stainless steel. The units include a polyester powder coated drain tray. Heat exchange coils comprise aluminium corrugated plate fins on mechanically expanded rifled copper tube. The outdoor coil fins are epoxy coated for extra protection in corrosive environments, e.g. salt laden sea air.

Self Diagnostics. The Outdoor Unit Controller (OUC) has a display of LEDs to indicate faults and running conditions. A non-specific fault indicator is included for interface to external systems.

STANDARD EQUIPMENT

Indoor Air Section:

1. Coil
2. Fan - forward curved centrifugal
3. Fan motor - multi-speed, direct drive
4. Drain tray - sloping, powder coated
5. Supply and return air spigots

Outdoor Air Section

1. Compressor
2. Coil
3. Fans - propeller
4. Fan motors - multi-speed, direct drive
5. Fan guard
6. High pressure switches
7. Accurator expansion device
8. Circuit breaker control
9. Reversing valve
10. Outdoor Unit Controller (OUC).

OPTIONAL EQUIPMENT

1. SAT-1 Controller.
2. Electric booster heat kit (internal)
 - 3.0 kW for OPA 100
 - 4.5 kW for OPA 135, 155, 178Complete with heater safety cutout required to meet AS/NZS 3350.2.40 1997.

SAFETY FEATURES

1. HP and loss of refrigerant protection.
2. Anti-rapid cycle timer and internal overload for compressor protection.
3. Circuit breaker control circuits.
4. Time-and-temperature controlled electronic de-ice switch prevents icing up of the outdoor coil during heating cycle.
5. Frost protection on cooling cycle.
6. Sensor fault indication.
7. Crankcase heater prevents liquid refrigerant condensing in the compressors during the 'off' cycle.
8. Compressor minimum run time to ensure oil return.

COMPRESSOR

Each high efficiency scroll type compressor is hermetically sealed, quiet running and supported on rubber mounts to minimise vibration.

REFRIGERATION SYSTEM

The OPA units are factory charged with HFC-410A (R410A) refrigerant.

WIRING

The electrical supply required (including voltage fluctuation limits) is: 3 phase 342-436 V a.c. 50 Hz with neutral and earth.

The compressor crankcase heater requires a 24 hour power supply. The units control panel is fully wired ready to accept the main power supply.

The manufacturer operates a quality management system that conforms to AS/NZS ISO 9001:2000.

PERFORMANCE DATA

COOLING CAPACITY (kW)

Total = Total Capacity (kW) Sens. = Sensible Capacity (kW)
 E.A.T. = Entering Air Temperature ○ = Nominal Capacity (kW)

Note: Capacities are **gross** and do not include allowance for fan motor heat loss. For fan motor heat loss refer to Air Handling graphs.

MODEL	INDOOR FAN		INDOOR COIL E.A.T.		OUTDOOR COIL ENTERING AIR TEMPERATURE °C D.B.											
	SPEED	AIR l/s	W.B. °C	D.B. °C	23		27		31		35		39		43	
					Total	Sens.	Total	Sens.	Total	Sens.	Total	Sens.	Total	Sens.	Total	Sens.
OPA 100	HIGH	550	15	21	10.3	7.8	10.0	7.8	9.7	7.7	9.4	7.6	9.1	7.4	8.8	7.3
			17	23	10.8	8.0	10.6	7.8	10.3	7.7	10.0	7.6	9.7	7.4	9.4	7.3
			19	27	11.5	9.1	11.2	9.0	10.9	8.8	10.6	8.8	10.3	8.7	9.9	8.6
			21	31	12.2	10.3	11.8	10.2	11.5	10.1	11.3	10.0	10.9	9.9	10.5	9.8
OPA 135	HIGH	775	15	21	13.7	10.8	13.5	10.8	13.1	10.6	12.5	10.2	11.7	9.7	10.6	8.9
			17	23	14.4	10.6	14.2	10.6	13.8	10.4	13.2	10.1	12.4	9.6	11.4	8.9
			19	27	15.2	12.1	14.9	12.1	14.6	11.9	13.9	11.6	13.1	11.0	12.1	10.3
			21	31	15.9	14.3	15.7	14.3	15.3	14.2	14.7	13.8	13.8	13.1	12.8	12.3
OPA 155	HIGH	850	15	21	14.8	11.2	14.4	11.2	13.9	11.0	13.5	10.8	13.1	10.7	12.6	10.4
			17	23	15.5	11.4	15.2	11.2	14.8	11.0	14.4	10.8	13.9	10.7	13.5	10.5
			19	27	16.5	13.0	16.0	12.9	15.6	12.6	15.2	12.6	14.8	12.4	14.3	12.3
			21	31	17.5	14.8	17.0	14.6	16.6	14.4	16.1	14.3	15.6	14.2	15.1	14.0
OPA 178	HIGH	950	15	21	17.7	13.4	17.2	13.4	16.7	13.2	16.2	13.0	15.7	12.8	15.1	12.5
			17	23	18.6	13.7	18.2	13.4	17.7	13.2	17.2	12.9	16.7	12.8	16.2	12.5
			19	27	19.8	15.6	19.2	15.4	18.7	15.1	18.2	15.1	17.7	14.9	17.1	14.7
			21	31	20.9	17.7	20.3	17.5	19.8	17.3	19.3	17.2	18.7	17.0	18.1	16.7

Indoor Air Flow Correction Factors @ nominal conditions

	Indoor Air Flow (%)			
	-20%	-10%	Rated	+10%
Total Capacity	0.95	0.975	1.0	1.025
Sensible Capacity	0.89	0.950	1.0	1.050

HEATING CAPACITY (kW)

G = Gross Heating Capacity kW, based on nominal air flow.
 N = Net Heating Capacity kW allowing for average defrost.

○ = Nominal Capacity (kW)

MODEL	INDOOR ENTERING AIR TEMP. °C D.B.	OUTDOOR COIL ENTERING AIR TEMPERATURE (E.A.T.) °C D.B.															
		-5		-3		-1		1		3		5		7		9	
		G	N	G	N	G	N	G	N	G	N	G	N	G	N	G	N
OPA 100	15	7.3	6.6	7.9	7.1	8.4	7.6	9.0	7.9	9.5	8.0	10.2	9.2	10.9	10.8	11.4	11.4
	20	7.1	6.4	7.7	7.0	8.3	7.4	8.8	7.7	9.3	7.9	10.0	9.0	10.7	10.5	11.2	11.2
	25	6.9	6.2	7.4	6.7	8.0	7.2	8.5	7.5	9.0	7.6	9.6	8.7	10.3	10.2	10.8	10.8
OPA 135	15	9.2	8.0	9.9	8.5	10.6	8.7	11.3	8.9	12.0	9.1	12.9	10.0	13.7	10.7	14.4	14.4
	20	9.0	7.9	9.7	8.4	10.4	8.6	11.1	8.8	11.8	8.9	12.6	9.2	13.4	10.5	14.1	14.1
	25	8.6	7.6	9.4	8.1	10.0	8.3	10.7	8.4	11.3	8.6	12.2	8.9	12.9	10.1	13.6	13.6
OPA 155	15	10.7	9.6	11.5	10.4	12.3	11.1	13.1	11.6	13.9	11.8	15.0	13.5	15.9	15.8	16.7	16.7
	20	10.5	9.4	11.3	10.2	12.1	10.9	12.9	11.3	13.7	11.5	14.7	13.2	15.6	15.4	16.4	16.4
	25	10.1	9.1	10.9	9.8	11.6	10.5	12.4	10.9	13.1	11.1	14.1	12.7	15.0	14.9	15.8	15.8
OPA 178	15	12.3	11.1	13.3	12.0	14.2	12.8	15.1	13.3	16.1	13.6	17.3	15.5	18.4	18.2	19.3	19.3
	20	12.1	10.9	13.1	11.7	14.0	12.6	14.9	13.1	15.8	13.3	16.9	15.2	18.0	17.8	18.9	18.9
	25	11.6	10.5	12.6	11.3	13.4	12.1	14.3	12.6	15.2	12.8	16.3	14.7	17.3	17.2	18.2	18.2

PERFORMANCE DATA

AIR HANDLING

Note: Airflows are for a dry coil. Reduce airflow by 5% in high moisture removal conditions. In a free blow or low resistance application, beware of exceeding indoor fan motor's full load amp limit (refer back page). Air flows given are for units installed without filters. If using EU-2 filter media, provide 0.08 m² face area per 100 l/s of airflow to maximise efficiency.

OPA 100

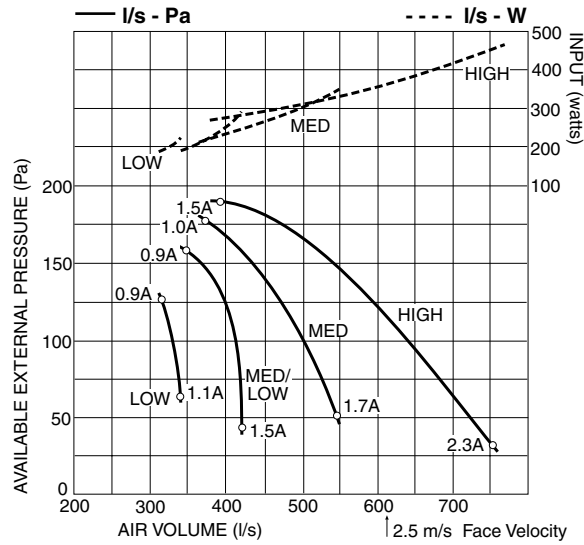

OPA 135, 155

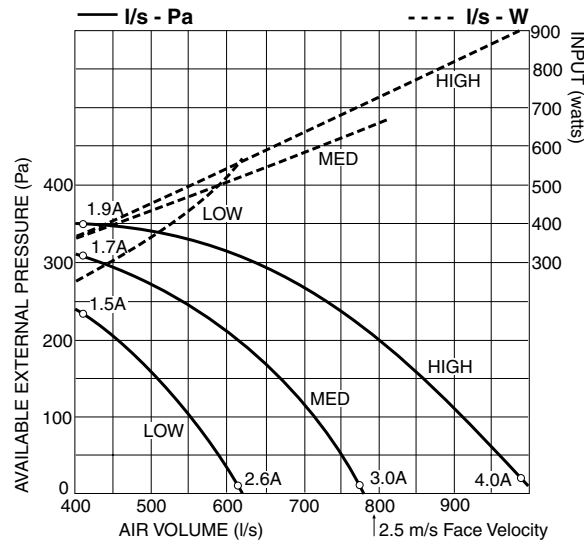

OPA 178

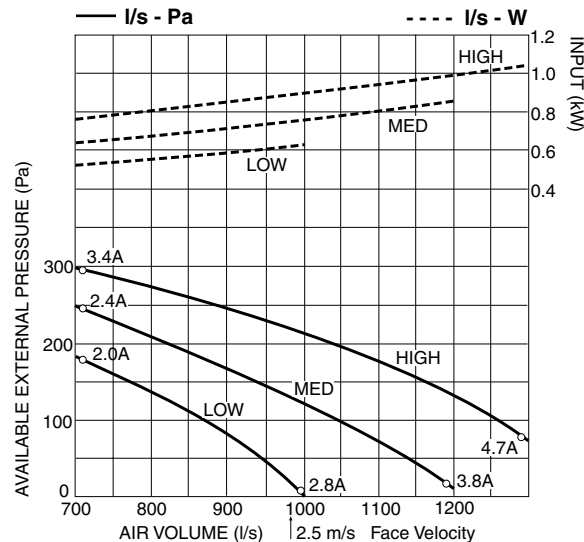

PERFORMANCE DATA

SOUND LEVELS

Radiated

Sound Power Levels (SWL)

Measured in decibels re 1 picowatt, at nominal airflow.

MODEL	OUTDOOR FAN SPEED	SWL dB(A)	OCTAVE BAND FREQUENCY Hz					
			125	250	500	1 k	2 k	4 k
			SOUND POWER LEVELS (SWL) dB					
OPA 100	LOW	63	67	61	60	60	51	47
	MED	65	68	64	63	61	53	48
OPA 135/155	MED	70	75	71	68	64	60	53
	HIGH	71	77	72	69	66	61	55
OPA 178	MED	68	81	67	63	60	54	48
	HIGH	71	83	70	67	63	59	52

Sound Pressure Levels (SPL)

Measured in decibels re 20 µPa, at nominal airflow.

MODEL	OUTDOOR FAN SPEED	SPL @ 3 m dB(A)	OCTAVE BAND FREQUENCY Hz					
			125	250	500	1 k	2 k	4 k
			SOUND PRESSURE LEVELS (SPL) dB					
OPA 100	LOW	47	51	45	44	44	35	31
	MED	49	52	48	47	45	37	32
OPA 135/155	MED	54	59	55	52	48	44	37
	HIGH	55	61	56	53	50	45	39
OPA 178	MED	52	65	51	47	44	38	32
	HIGH	55	67	54	51	47	43	36

Sound Power Levels (SWL)

Test Conditions: BS 848 PT2 1985. Installation Type A (free inlet and outlet). Direct method of measurement (reverberant room). Measured in decibels re 1 picowatt.

Supply Air Outlet

MODEL	INDOOR FAN SPEED	AIR FLOW l/s	SWL dB(A)	OCTAVE BAND FREQUENCY Hz					
				125	250	500	1 k	2 k	4 k
				SOUND POWER LEVELS (SWL) dB					
OPA 100	LOW	320	53	51	51	51	47	44	40
	MED-LOW	400	59	56	56	57	53	52	50
	MED	500	65	60	61	63	59	58	56
	HIGH	625	69	63	64	66	63	61	60
OPA 135/155	LOW	550	67	67	65	63	62	61	56
	HIGH	900	73	72	69	68	69	66	64
OPA 178	LOW	900	66	61	55	50	45	40	37
	MED	1000	68	81	67	63	60	54	48
	HIGH	1100	71	83	70	67	63	59	52

SPECIFICATIONS

Model		OPA 100	OPA 135	OPA 155	OPA 178
Cooling Capacity *1	kW	10.6	13.9	15.2	18.2
Heating Capacity *2	kW	10.7	13.4	15.6	18.0
E.E.R. (Cooling)		2.80	3.01	2.78	3.07
Air Flow *3	l/s	575	775	850	950
Power Source *4		3 phase 342-436 V a.c. 50 Hz			
Indoor Fan Full Load Amps	A	1.89	5.0	5.0	6.3
Running Amps (Total System)	A/ph.	7 / 5 / 6	11 / 8 / 8	11 / 8 / 8	12 / 8 / 8
Recommended External Fuse	A/ph.	25	25	25	25
Finish		grey polyester powder coat			
Net Weight	kg	160	189	189	209
Shipping Weight (approx.)	kg	180	225	225	248

Notes:

*1 Nominal Cooling Capacity at AS/NZS 3823 conditions:
Indoor Entering Air Temp. 27°C D.B., 19°C W.B.;
Outdoor Entering Air Temp. 35°C D.B.
Subtract indoor fan power to calculate Net Capacity.

*2 Heating Capacity at AS/NZS 3823 conditions:
Indoor Entering Air Temp. 21°C D.B.;
Outdoor Entering Air Temp. 7°C D.B., 6°C W.B.

*3 Supply air flow at Nominal Cooling Capacity conditions stated above.

*4 Power source includes voltage limits.

DIMENSIONS (mm)

Not to Scale

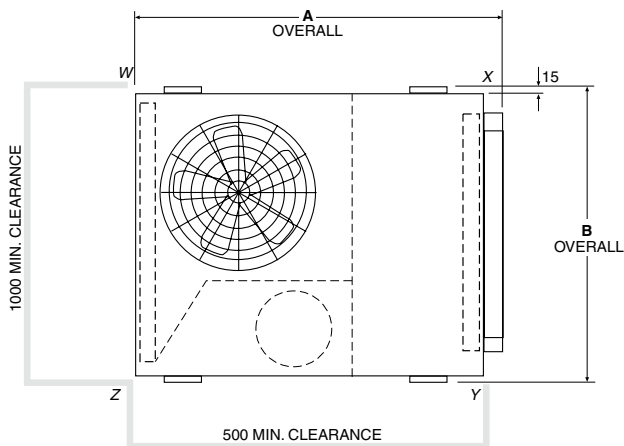
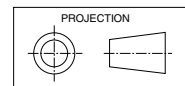

MODEL	A	B	C	D	E	F	G	H	J	K	L
OPA 100	1160	1050	805	400	831	315	162	100	1035	266	725
OPA 135/155	1110	1200	805	860	1065	160	140	80	1185	283	675
OPA 178	1160	1200	960	860	1062	160	205	75	1185	342	725

MODEL	POINT LOADS (kg)			
	W	X	Y	Z
OPA 100	39	36	41	44
OPA 135	36	43	58	52
OPA 155	35	42	57	50
OPA 178	40	47	61	54

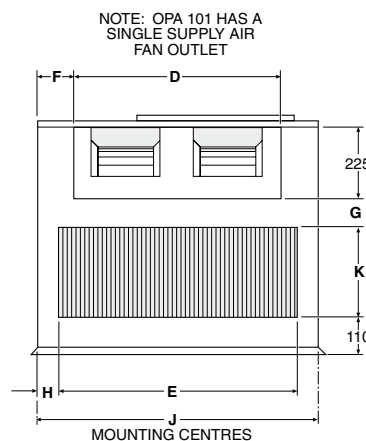
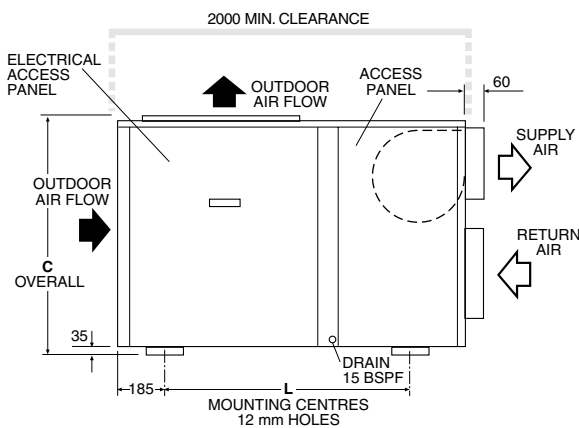

NOTE

The manufacturer reserves the right to make changes in specifications at any time without notice or obligation. Certified data is available on request.



temperzone limited

Head Office, Auckland : 38 Tidal Rd, Mangere, N.Z.
Private Bag 93303, Otahuhu, NEW ZEALAND.
Email sales@temperzone.co.nz Website: www.temperzone.biz

temperzone australia pty ltd

Head Office, Sydney : 7A Bessemer St
PO Box 6448, Delivery Centre, Blacktown, NSW 2148,
AUSTRALIA. Email sales@temperzone.com.au

AUCKLAND

Ph. 0-9-279 5250
Fax 0-9-275 5637

WELLINGTON

Ph. 0-4-569 3262
Fax 0-4-566 6249

CHRISTCHURCH

Ph. 0-3-379 3216
Fax 0-3-379 5956

SYDNEY

Ph. (02) 8822-5700
Fax (02) 8822-5711

ADELAIDE

Ph. (08) 8376-1505
Fax (08) 8376-1449

SINGAPORE

Ph. SNG 6733 4292
Fax SNG 6235 7180

MELBOURNE

Ph. (03) 9551-7422
Fax (03) 9551-8550

BRISBANE

Ph. (07) 3399-2544
Fax (07) 3399-2577

NEWCASTLE

Ph. (02) 4962-1155
Fax (02) 4961-5101



PERTH

Ph. (08) 9314-3844
Fax (08) 9314-3855

TOWNSVILLE

Ph. (07) 4773-9566
Fax (07) 4773-9166

HOBART

Ph. (03) 6272-0066
Fax (03) 6272-0506

Available from