

## OPA 260RA

# Packaged Reverse Cycle Air Cooled Air Conditioner

# Installation & Maintenance

### GENERAL

The OPA 260RA is a tandem compressor (single circuit) system that provides the facility for capacity control (staging) or staggered starting.

This OPA 260RA unit must be installed in accordance with all national and local safety codes.

### CONFIGURATIONS

The OPA 260RA is supplied in one of three standard configurations :

1. Horizontal supply/return air with mounting rails,
2. Downward supply air with mounting rails, or
3. Downward supply air with plinth mount.

### REFRIGERATION SYSTEM

#### General

The refrigeration system has been charged with 7.5 kg of HCFC-22 (R22) refrigerant. Tapping points are provided to measure discharge and suction operating pressures.

#### Compressors

The compressors are directional scroll type. The compressor lubricant is polyol ester oil (POE). Note, this oil absorbs moisture quickly if exposed to open air. On commissioning, the compressors must be checked for correct rotation (refer Start Up Procedure).

### ECONOMISER (Option)

If the outdoor air heat content or temperature is below that of the return air, the fresh air damper opens and the return air damper closes to provide the first stage of cooling. The compressor(s) will then operate to provide more cooling if required.

### INSTALLATION

#### Unpacking

Units configured with Downward supply air and mounting rails, have their spigots shipped loose inside the return air cavity.

#### Positioning

Refer to dimension diagrams for minimum clearances. If multiple units are to be placed side-by-side then allow at least 2 m between coil faces.

#### Mounting

The unit should be fastened to a firm flat horizontal base using the holes supplied in the mounting rails. Refer to figure 4 for plinth mount details.

When the unit is being installed on a roof it is recommended that the unit is installed on a substantial structure with vibration isolating springs beneath the unit. These springs are not supplied with the unit.

Two channels are provided under the base for spring mounts or bolting down.

Flexible duct connections are recommended between the supply and return ducts and the unit.

#### Condensate Drain

The condensate drain should be 'U' trapped outside the unit. The trap should have a Downward height of at least 100 mm. The drain should have a slope of at least 1 in 50 and must not be piped to a level above the unit drain pipe (see figure 5).

#### Electrical Requirements

Electrical work must be done by a qualified electrician. The outdoor unit must be wired directly from a distribution board by means of a circuit breaker or H.R.C. fuse, and a mains isolator provided - preferably close to the unit.

**Note:** DO NOT USE REWIRABLE FUSES.

The OPA 260RA is provided with a 24V AC control circuit for a thermostat, on/off switch and/or time clock.

The control transformer 240V primary voltage is used for countries with 230-240V power supply. For countries with supply voltages 200-220V, change the primary voltage on the transformer to 208V.

Standard units are suitable for use with thermostats with either manual Heat/Cool selection or automatic changeover subject to the contact ratings of the thermostats.

Capacity control, if required, is achieved by controlling the two compressors independently using a two stage thermostat. A staggered start of two compressors ensures a lower starting current.

A 24 hour power supply to the compressor crank case heaters is required, otherwise the warranty is void.

### CHECK TESTS

1. Leave the on/off switch in the off position and close the mains isolating switch. A four hour delay period is required to allow the crankcase heaters to drive any liquid refrigerant out of the compressor oil.
2. Check that all fan motors are free running.
3. Check that the thermostat is correctly wired to the unit and is set at the desired temperature.
4. Check that the air filters have been correctly installed if fitted.
5. Check air diffuser dampers are open if appropriate.

### START UP PROCEDURE

Use the supplied Commissioning Sheet to help you complete the following procedure:

1. After the four hour delay period has expired, switch on the unit.
2. The compressor fitted is directional. Check for correct rotation. If rotation is incorrect the compressor will not pump, be noisy, and will draw minimal current. To correct motor rotation, change the phasing at the main power terminal.

3. Check the supply voltage between each phase and neutral.
4. Measure the current draw on each phase to the compressor motor and measure the current draw of each fan motor. Check all readings against the specified values in the wiring diagram.
5. Fit gauges and measure the suction and discharge pressures of both refrigeration circuits.
6. Check that the outdoor air fan motors are running smoothly.
7. Test the operation of the reversing valve by running the unit in both the heating and cooling mode.
8. Check the indoor unit's fan belt tension after 20 mins of operation and adjust if necessary (refer Commissioning Sheet).
9. Check the supply air flow at each outlet.
10. Check the tightness of all electrical connections and sign the check label.
11. Touch up any outdoor unit paintwork damage to prevent corrosion.

### SETTING SUPPLY AIR FLOW

Consult OPA 260RA Technical Data pamphlet for details of airflow/duct static pressure, if required.

If the indoor air returning to the unit is regularly expected to be above 50%RH, then the coil face velocity should be limited to be 2.5 m/s or less (refer Air Handling graph in Technical Data pamphlet).

High humidity levels can occur in tropical or subtropical conditions, and/or when heavily moisture laden fresh air is introduced. Select a fan speed that avoids water carry-over problems.

In a free blow or low resistance application, beware of exceeding the fan motor's full load amp limit (refer wiring diagram).

The indoor air fan motor is fitted with a factory set adjustable pitch pulley. Instructions for the adjustment of pulleys is included on the back page of the supplied Commissioning Sheet. One revolution of adjustment is equal to approx. 7% change in air volume flow rate.

### OUTDOOR UNIT CONTROLLER (OUC)

The Outdoor Unit Controller (OUC) includes a temperature sensing head pressure control which enables the system to compensate for outdoor ambient temperatures below 20°C on cooling cycle, and above 15°C on heating cycle. The OUC also has features which protect against icing or overheating of coils, rapid cycling of the compressor and loss of refrigerant charge.

If the outdoor unit fans take some time to begin rotating when the system is powered on, or they don't appear to be rotating appropriately while the compressor is running, consult the OUC label on the electrical box. If necessary, refer to

temperzone for further diagnostic information.

**MAINTENANCE**

**Monthly**

1. Check air filters, if fitted, and vacuum or wash clean as necessary.
2. Check condensate drain for free drainage.
3. Check compressor compartment for oil stains indicating refrigerant leaks.

**Three Monthly (or every 1200 hrs of operation)**

Check the indoor unit's fan belt tension and adjust if necessary.

**Six Monthly**

1. Check the tightness of electrical connections.
2. Check the tightness of fans, motor mountings, pulleys and belt tension.
3. Check suction and discharge operating pressures.
4. Replace indoor air filters (if fitted).
5. Check condensate drain for free drainage.

**Yearly**

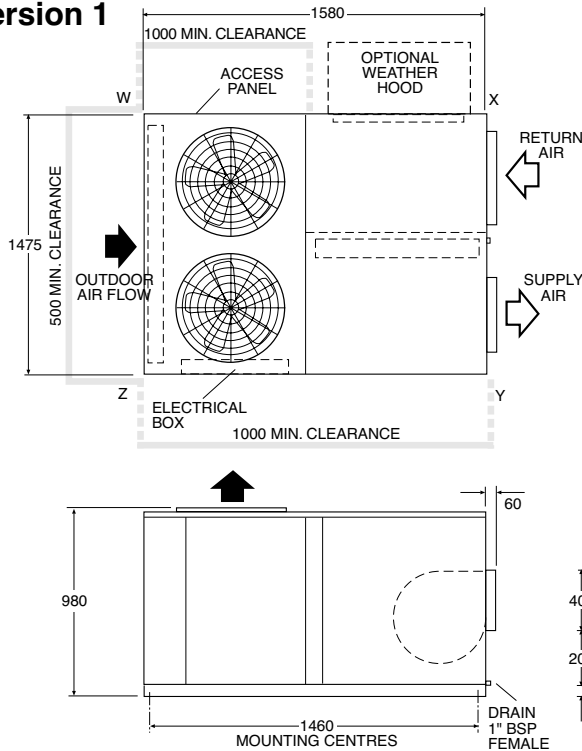
1. Check all refrigerant piping for chafing and vibration.
2. Check the operation of electric heaters, if fitted.
3. Check air supply at all diffusers.

4. Check for excessive noise and vibration and correct as necessary.
5. Check fan and motor bearings and lubricate or replace as necessary.
6. Check for insulation and duct damage and repair as necessary.
7. Remove lint and dust accumulation from outdoor coil fins.
8. Touch up any paintwork damage to prevent corrosion.

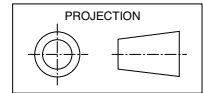
This pamphlet replaces the previous issue no. 2633 dated 09/06. Wiring revision C.

**DIMENSIONS (mm)**

**Fig. 1 Horizontal Supply & Return Air / Mounting Rails Version 1**



**OPA 260RA**

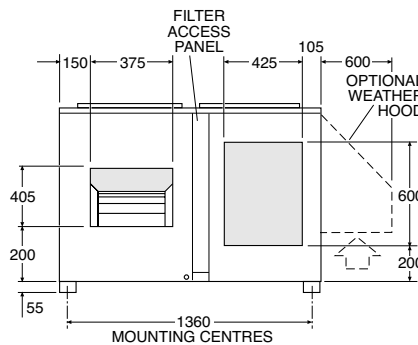


Not to Scale

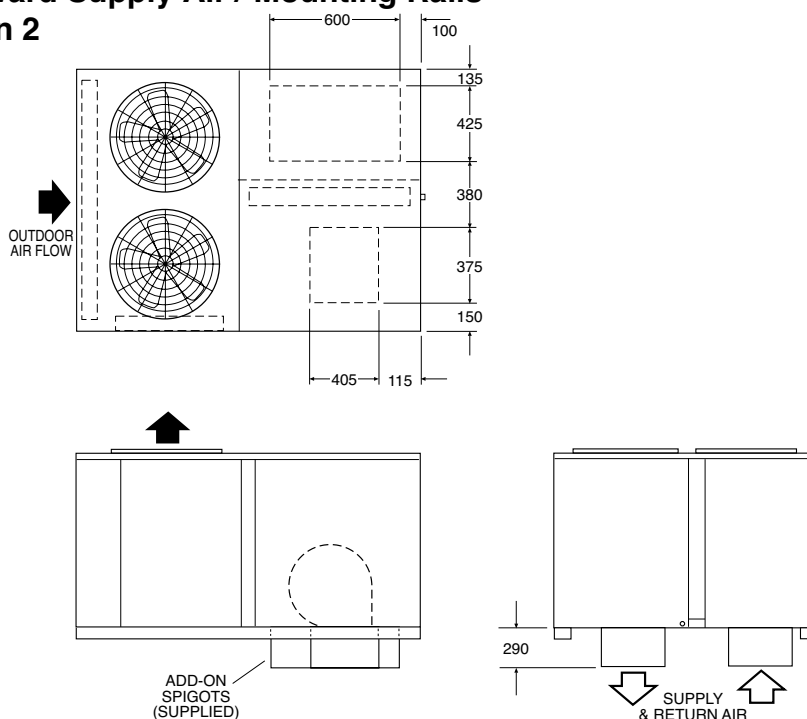
POINT LOADS (kg)			
W	X	Y	Z
132	96	68	105

Net Weight 401 kg

**Note :** A 2 m clearance is required above the exhaust air fans



**Fig. 2 Downward Supply Air / Mounting Rails Version 2**



**NOTE**

The manufacturer reserves the right to make changes in specifications at any time without notice or obligation. Certified data is available on request.

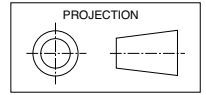
**Note:**

Supply and return air spigots are shipped loose inside the return air cavity.

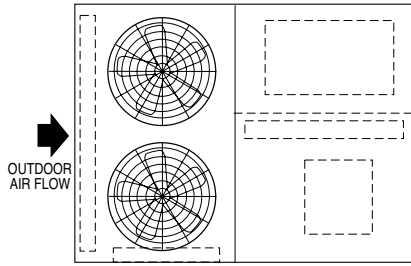
**DIMENSIONS (mm)**

**OPA 260RA**

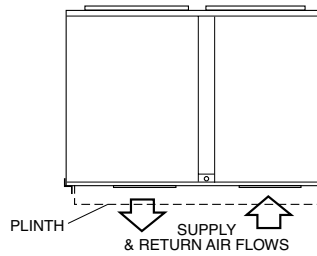
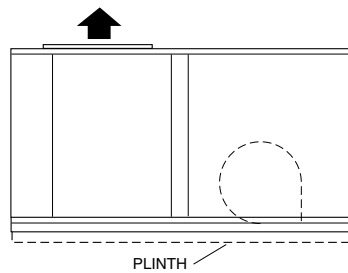
**Fig. 3 Downward Supply Air / Plinth Mounted Version 3**



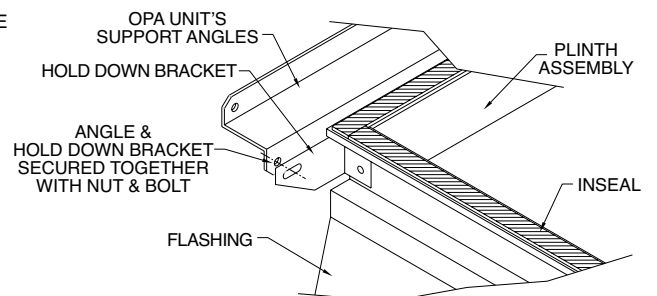
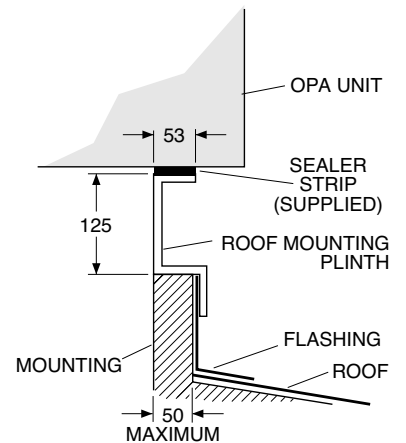
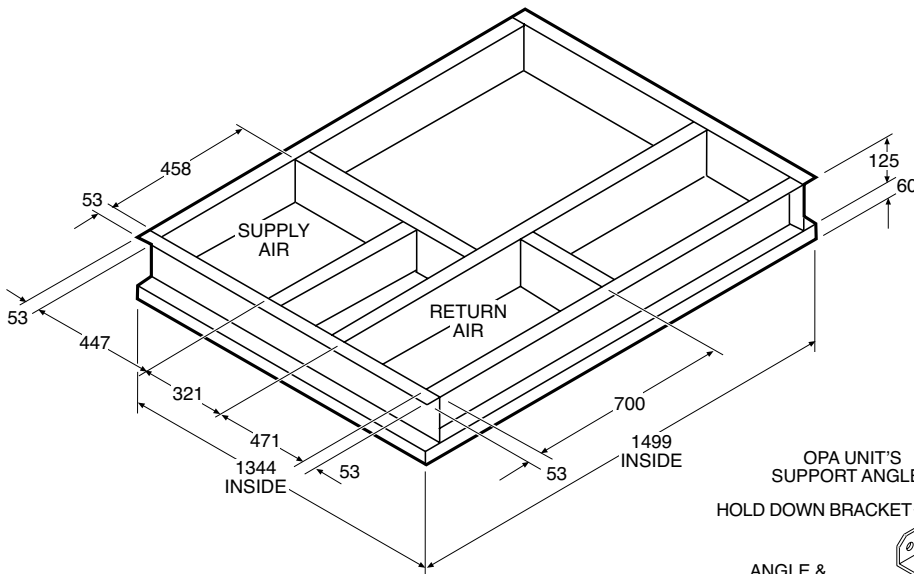
Not to Scale



**Note:**  
Refer to Fig.1 for overall dimensions and Fig.4 for further plinth dimensions.

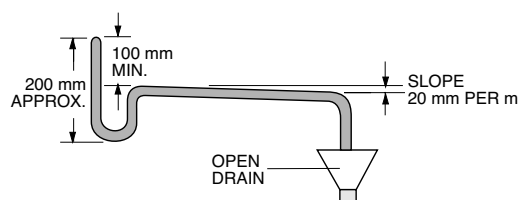


**Fig. 4 Roof Mounting Plinth (Kitset)**



**TYPICAL CORNER ASSEMBLY**

**Fig. 5 Condensate Drain**



**NOTE**  
The manufacturer reserves the right to make changes in specifications at any time without notice or obligation. Certified data is available on request.

CAPACITIES - NET to AS/NZS 3823	
COOLING -	kW 24.65
HEATING - REVERSE CYCLE	kW 27.7
ELECTRICAL INPUT	
COOLING -	kW 9.3
HEATING - REVERSE CYCLE	kW 7.7
E.E.R. (COOLING)	kW/kW 2.65
ELECTRICAL	
SUPPLY REQUIRED 3Ph 342-436V ~ 50Hz INCLUDING VOLTAGE FLUCTUATION LIMITS	
COMPRESSOR (3Ph) RUN AMPS RATED CONDITIONS	A/Ph 6.7/COMP.
COMPRESSOR (3Ph) STARTING AMPS	A/Ph 10
INDOOR FAN MOTOR (3Ph) FULL LOAD AMPS	A/Ph 2.76
INDOOR FAN MOTOR	kW 1.5
OUTDOOR FAN MOTOR (1Ph) FULL LOAD AMPS	A 1.5 x2
OUTDOOR MOTOR CAPACITOR	MFD 6 x2
RUNNING AMPS (TOTAL)	A 15/15/17
RECOMMENDED EXTERNAL FUSE SIZE	A/Ph 32
ELECTRIC HEAT OPTION	6 kW TOTAL, 8.7 A/Ph
RECOMMENDED EXTERNAL FUSE SIZE WITH ELECTRIC HEAT OPTION	A/Ph 40
WEIGHT-NETT OPA 260RA	kg 401
REFRIGERANT - HCFC (R22)	kg 7.5


APS	AIR PRESSURE SWITCH	FRC	INDOOR FAN CONTROL RELAY COIL
CAP	CAPACITOR	HR	HEATING RELAY
CB	CIRCUIT BREAKER	HRC	HEATING RELAY COIL
CCH	CRANKCASE HEATER	HP	HI PRESSURE SWITCH
CM	COMPRESSOR MOTOR	HST	HI TEMP. SAFETY
CMCC	COMPRESSOR CONTACTOR	IFC	INDOOR FAN CONTACTOR
CMCC	COMPRESSOR CONTACTOR COIL	IFCC	INDOOR FAN CONTACTOR COIL
CMCC	COMPRESSOR OVERLOAD	IFM	INDOOR FAN MOTOR
CIR	COMPRESSOR 1 RELAY 24 V CONTROL	IFOL	INDOOR FAN OVERLOAD
C1RC	COMPRESSOR 1 RELAY 24 V COIL 24V	LAT	LOW AMBIENT T/STAT
C2RC	COMPRESSOR 2 RELAY 24 V COIL 24V	LP	LOW PRESSURE SWITCH
C2RC	COMPRESSOR 2 RELAY COIL 24V	MST	MANUAL HI TEMP SAFETY
DMF	DAMPER MOTOR FRESH AIR	OFM	OUTDOOR FAN MOTOR
DMR	DAMPER MOTOR RETURN AIR	OUC	OUTDOOR UNIT CONTROLLER
DO	TIME DELAY 30 SEC. DELAY ON MAKE	PRC	PHASE ROTATION CONTROL
EHCC	ELECTRIC HEAT CONTACTOR	PRR	PHASE ROTATION RELAY
EHCC	ELECTRIC HEAT CONTACTOR COIL	PRRC	PHASE ROTATION RELAY COIL
F	INDOOR FAN CONTROL	RCV	REVERSE CYCLE VALVE
FR	INDOOR FAN CONTROL RELAY		

Consult Outdoor Unit Controller label for further details, or refer to Temperzone for fault diagnosis information.

Sensor Locations

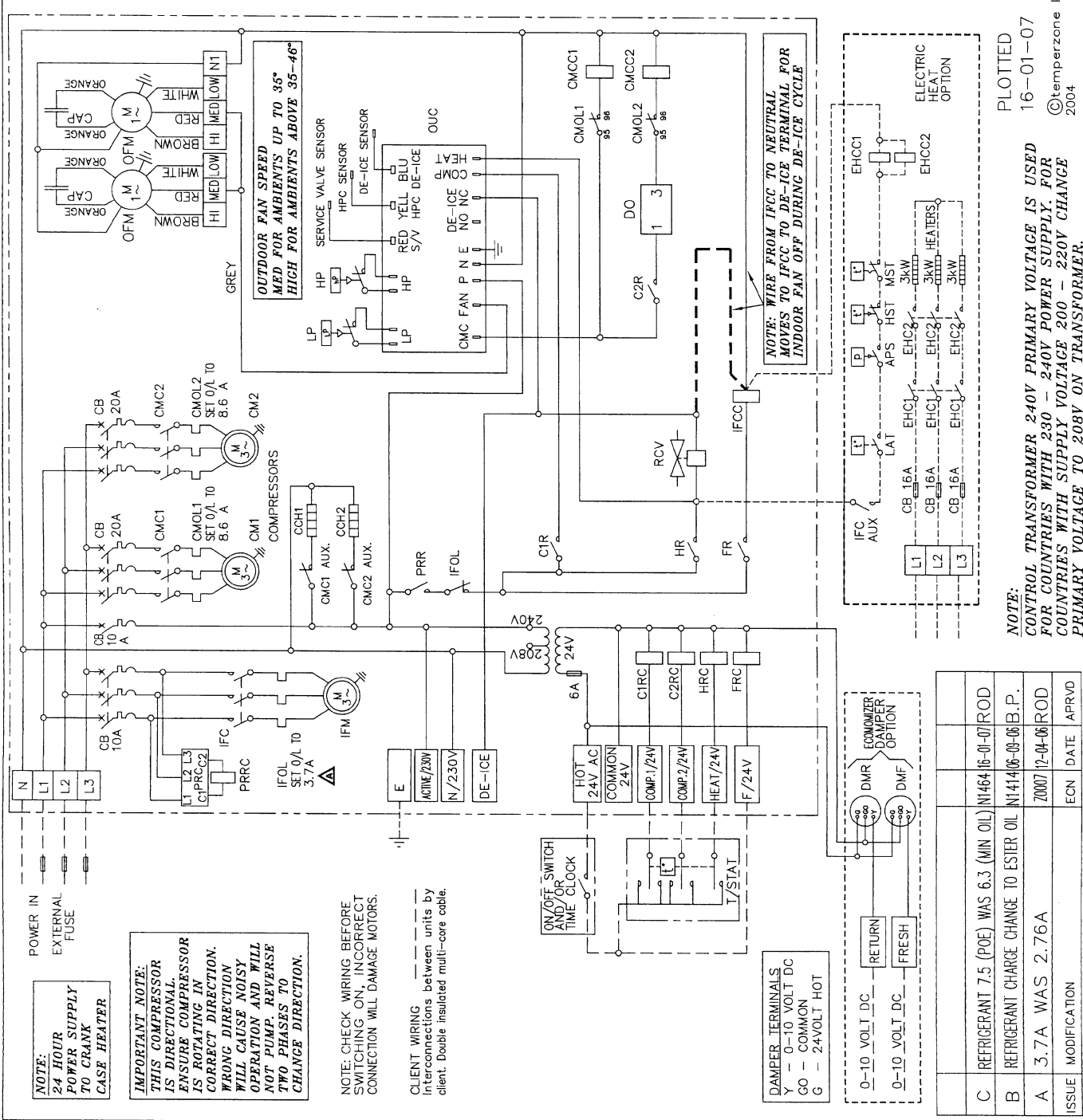
Red to service valve pipe pocket.  
Yellow to coil return bend pocket.  
Blue to bottom of coil in fins.

Title  
**OPA 260RA (OUC)  
WIRING SCHEMATIC**



Drawing No. 456-254-002  
Revision C

Date 26-11-04  
Scale *Asvd c.*



PLOTTED  
16-01-07  
©Temperzone Ltd  
2004

ISSUE	MODIFICATION	ECN	DATE	APRVD
C	REFRIGERANT 7.5 (POE) WAS 6.3 (MIN OIL) N146416-01-07 ROD			
B	REFRIGERANT CHANGE TO ESTER OIL N141416-01-06 B.P.			
A	3.7A WAS 2.76A			